

For new designs refer to RT series.



Features

- SPST through DPDT contact arrangements.
- Immersion cleanable[§], tape sealed plastic case.
- Meets VDE 8mm spacing, 4kV dielectric, coil to contacts.
- Conforms to VDE 0435, 0631, 0700 and 0806.
- UL Class B coil insulation system.

§ For more details, refer to application note 13C265, "Mounting, Termination and Cleaning of PC Board Relays."

Contact Data @ 25°C

Arrangements: 1 Form A (SPST-NO), 1 Form B (SPST-NC), 1 Form C (SPDT), 2 Form A (DPST-NO) and 2 Form C (DPDT).

Material: Silver-cadmium oxide.

Expected Mechanical Life: 10 million operations.

Contact Ratings @ 25°C with relay properly vented. Remove tape over vent hole after soldering and cleaning.

Code	Arrangement	UL/CSA/VDE Ratings	Expected Life (Operations)
G & X	SPST or SPDT	10A @ 250VAC 10A @ 277VAC/30VDC 360VA @ 240VAC, Pilot Duty	100,000
		1/3 HP @ 250VAC 1/4 HP @ 120VAC	
		21.6 LRA, 10 FLA @ 240VAC 30 LRA, 10 FLA @ 125VAC 3A Tungsten @ 120VAC (TV-3)	30,000 25,000
	DPST-NO or DPDT	10A @ 277VAC 10A @ 30VDC	50,000
		1/4 HP @ 240VAC 360VA @ 240VAC, Pilot Duty 1/8 HP @ 120VAC	
G Only	SPST or SPDT	5A Tungsten @ 120VAC (TV-5)	25,000
W	SPST or SPDT	20A @ 277VAC/24VDC	20,000
		16A @ 250VAC 16A @ 277VAC/24VDC	50,000
		12A @ 250VAC 12A @ 277VAC/24VDC	100,000
		1 HP @ 240VAC 1/2 HP @ 120VAC	
		48 LRA, 8 FLA @ 240VAC 58.8 LRA, 16 FLA @ 120VAC	30,000
		5A Tungsten @ 120VAC (TV-5)	25,000

Initial Dielectric Strength

Between Open Contacts: 1,000V rms.

Between Adjacent Contacts: 2,500V rms.

Between Contacts and Coil: 4,000V rms.

Coil Data @ 25°C

Voltage: 5 to 110VDC.

Maximum Power @ 25°C: 1.6W.

Nominal Power @ 25°C: 520mW, approx.

Temperature Rise: 64°C per Watt.

Maximum Temperature Per UL508: Class B insulation: 130°C.

Duty Cycle: Continuous.

Initial Insulation Resistance: 100 megohms, min., at 25°C, 500VDC and 50% rel. humidity.

RKS series

5 To 20 Amp PC Board Miniature Relay

Meets VDE 8mm spacing, 4kV dielectric

File E22575

File LR15734-173

File Nos. 3436, 3491, 5369

Coil Data @ 25°C

	Nominal Voltage	DC Resistance in Ohms ±10%	Must Operate Voltage	Nominal Coil Current (mA)
DC Coils	5	47	3.6	106
	6	69	4.3	87
	9	155	6.5	58
	12	275	8.6	44
	18	620	13.0	29
	24	1,100	17.3	22
	48	4,400	34.6	11
	60	6,880	43.2	9
	110	23,100	79.2	5

Maximum Ambient Temperature vs. Coil Voltage

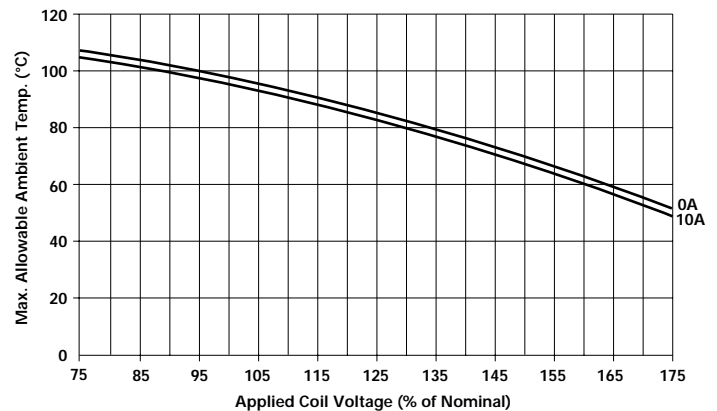

Operate Data @ 25°C

Must Operate Voltage: 72% of nom. voltage or less.

Operate Time (Excluding Bounce): 15 ms, typ., at nom. voltage.

Release Time (Excluding Bounce): 5 ms, max., at nom. voltage.

Environmental Data

Temperature Range:

Storage: -40°C to +130°C.

Operating: -40°C to +70°C (agency temperature).

Mechanical Data

Termination: Printed circuit terminals.

Enclosures: Immersion cleanable, tape sealed plastic case.

Weight: 0.65 oz. (18.5g) approximately.

Ordering Information

Typical Part Number ▶	RKS	-5	D	W	-12
1. Basic Series: RKS = Miniature, printed circuit board relay with immersion cleanable case.					
2. Contact Arrangement: 1 = 1 Form A (SPST-NO) 5 = 1 Form C (SPDT) 11 = 2 Form C (DPDT) 2 = 1 Form B (SPST-NC) 7 = 2 Form A (DPST-NO)					
3. Coil Input: D = DC voltage.					
4. Contact Rating & Wiring / PC Board Layout Diagram Codes: G = 10 amps, diagram code 1 for 1 pole models. X = 10 amps, diagram code 2 for 1 pole models. 10 amps, diagram code 4 for 2 pole models. 10 amps, diagram code 5 for 2 pole models. W = 20 amps, diagram code 3. Note: See diagrams below.					
5. Coil Voltage: 05 = 5VDC 09 = 9VDC 18 = 18VDC 48 = 48VDC 110 = 110VDC 06 = 6VDC 12 = 12VDC 24 = 24VDC 60 = 60VDC					

For new designs refer to RT series.

Stock Items – The following items are normally maintained in stock for immediate delivery.

RKS-1DG-12	RKS-1DW-24	RKS-5DG-24	RKS-5DW-24	RKS-7DX-24	RKS-11DX-05
RKS-1DG-24	RKS-5DG-05	RKS-5DW-05	RKS-5DW-48	RKS-11DG-12	RKS-11DX-12
RKS-1DW-12	RKS-5DG-12	RKS-5DW-12	RKS-5DX-12	RKS-11DG-24	RKS-11DX-24

Outline Dimensions

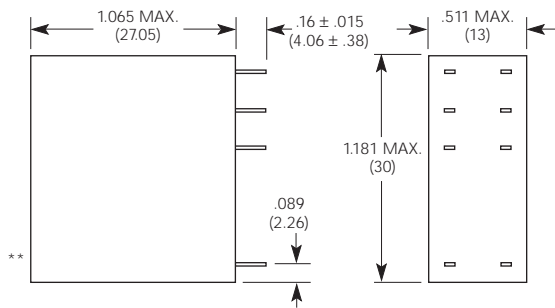

** Recommend tape tab be punctured or removed before relay is put in service.

RK PC Board Sockets

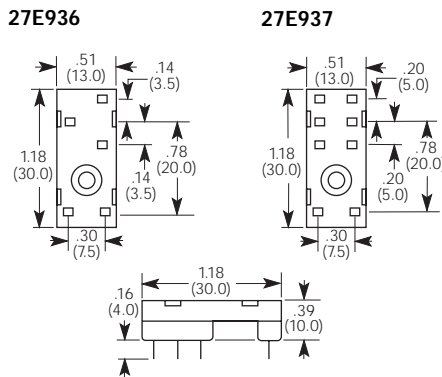

RK Screw Terminal Sockets

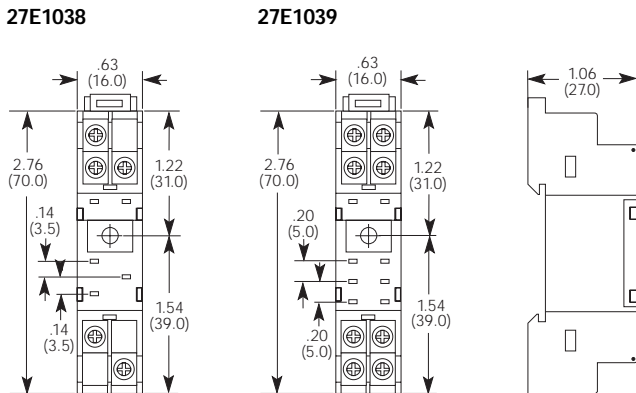

Wiring Diagrams (Bottom Views)

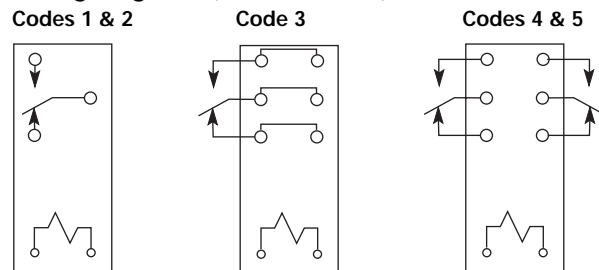

Note: On single throw models only necessary terminals are present.

PC Board Layouts (Bottom Views)

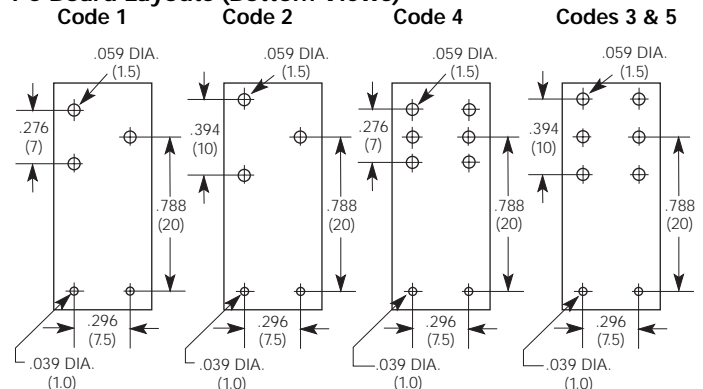

Note: On single throw models only necessary terminals are present.

RK Hold Down Spring

20C330

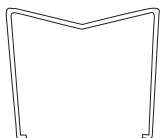

Note: Sockets UL approved for Class A insulation.