

**STRAIGHT PLUG SOLDER TYPE
CABLE .085**

R124.052.003
SERIES SMA-COM

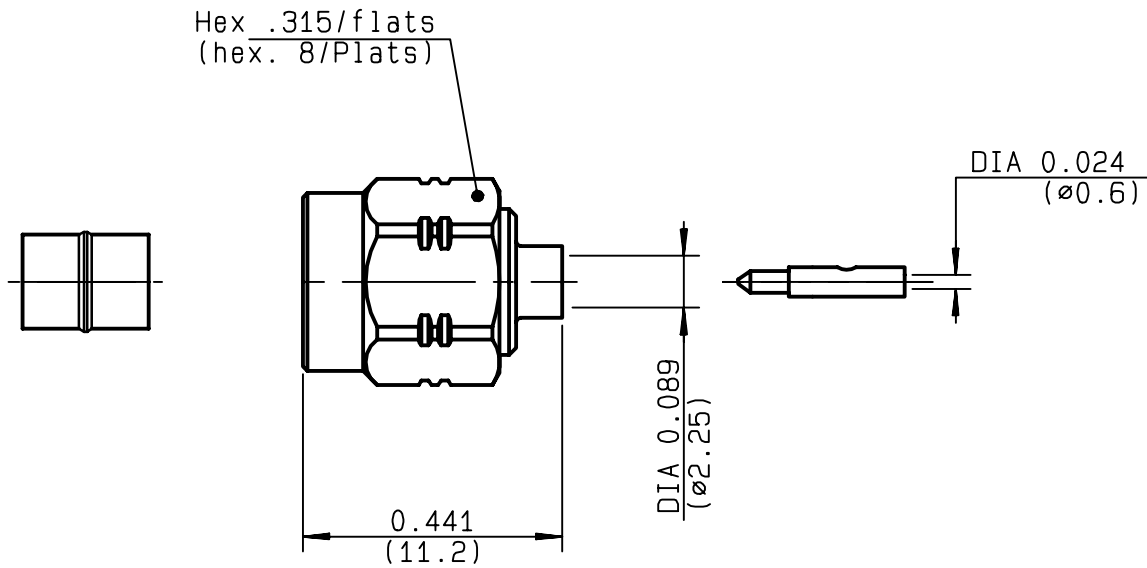

NOMINAL IMPEDANCE	50 Ω
FREQUENCY RANGE	0-18 GHz
TEMPERATURE RATING	-65/+105 °C
V.S.W.R	1.07 + .01 x F(GHz)Maxi
RF INSERTION LOSS	0.05 √F(GHz) dB Maxi
VOLTAGE RATING	335 Veff Maxi
DIELECTRIC WITHSTANDING VOLTAGE	750 Veff Mini
INSULATION RESISTANCE	5000 MΩMini
HERMETIC SEAL	NA Atm.cm ³ /s
LEAKAGE (pressurized only)	NA
MECHANICAL DURABILITY	100 Cycles
WEIGHT	2.25 gr
SPECIFICATION	

CABLES : KS 1 RG 405	
OTHERS CHARACTERISTICS	
CABLE RETENTION	130 N Mini
CENTER CONTACT RETENTION	
Axial force - mating end	NA N Mini
Axial force - opposite end	NA N Mini
Torque	NA cm.N Mini
RECOMMENDED TORQUES	
Mating	60 cm.N
Panel nut	NA cm.N
Clamp nut	NA cm.N

CONNECTOR PARTS	MATERIALS	FINISH
BODY	STAINLESS STEEL	GOLD 0.2 OVER NICKEL 2
OUTER CONTACT		
CENTER CONTACT	BRASS	GOLD 1.3 OVER COPPER 2.5
INSULATOR	PTFE	-
GASKET	SILICONE RUBBER	-
OTHERS PIECES	BRASS	GOLD 0.2 OVER NICKEL 2

(all values are given in micrometers)

TRIQUES

ISSUE	CREATION DATE	FILE PART-NUMBER
9910B00	12/11/1996	96-1200-062



RADIALL®

The information given here is subject to change without notice.
Design changes may be in order to improve the product.

Connect to the future



R124.052.003

ISSUE **9910B00** SERIES **SMA-COM**

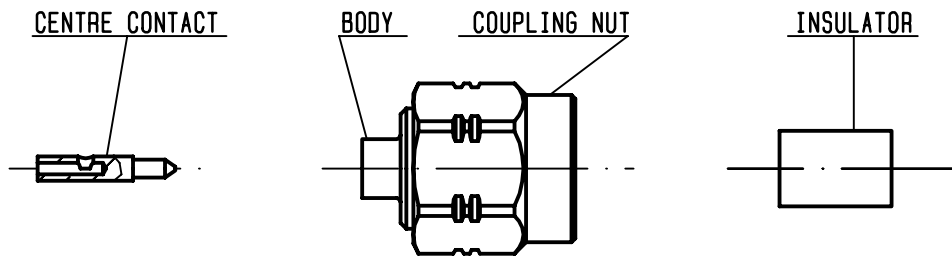

We recommend a cable thermal preconditioning before assembling

①

Strip the dielectric of the cable .
 Stripping tool cable : R 282 051 000.
 Trimmer : R 282 063 000 .
 Clean the cable .
 -

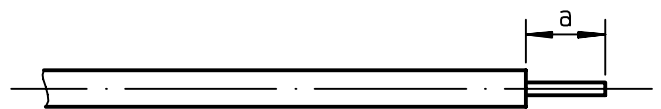

Stripping	a	b	c	d	e
inch	0.125 0	0	0	0	0
mm	3.17				

②

Screw the positioner R 282 744 220 onto the soldering jig R 282 740 000 .
 Slide contact into positioner .
 Insert solder gauge R 282 862 060 (61) between contact and cable .
 Tighten and solder the contact .

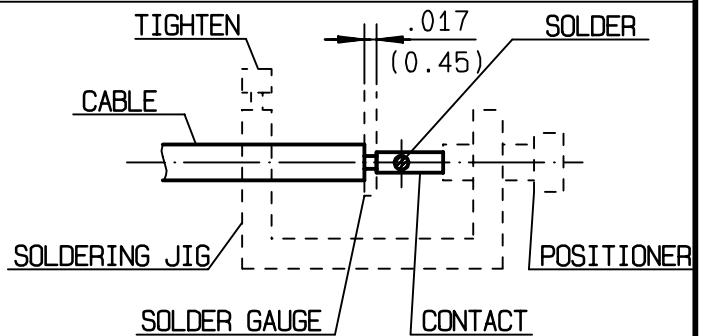

③

After cooling remove cable assembly from the jig .
 Screw positioner R 282 744 060 (85) into the connector .
 Slide cable into the connector until it bottoms againsts positioner .
 Tighten .
 Put 3 rings of solder around the cable and solder .

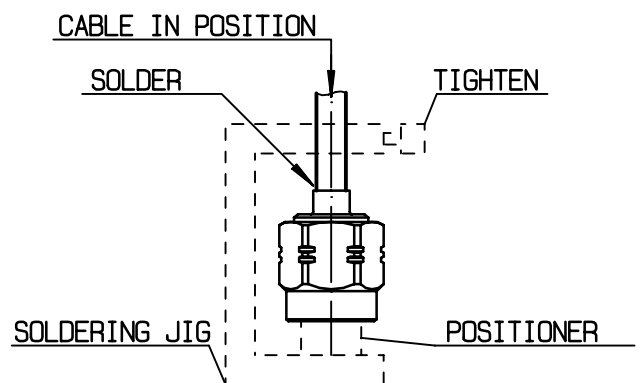

④

After cooling remove cable assembly from the jig .
 Screw dielectric recess gauge R282 914 000(93) and trim dielectric with the dielectric recess tool R 282 915 010.
 Screw female dielectric insert tool onto connector and insert insulator with the dielectric plunger R 282 730 040 .

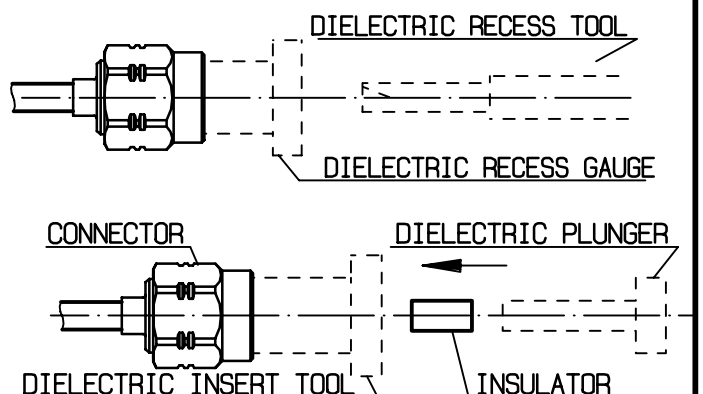

TRIQUES