

## Sub-miniature, Sensitive SPDT Signal Switching Relay

- ROHS compliant.
- High sensitivity: 98mW pickup coil power.
- Impulse withstand voltage meets FCC Part 68 requirements.
- Fully sealed construction.
- Unique moving loop armature reduces relay size, magnetic interference, and contact bounce time.
- Single- and double-winding latching types also available.

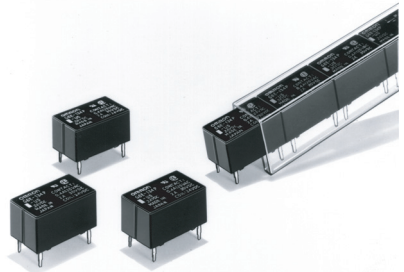

## Ordering Information

| Contact form |                     | Terminal                | Single-side stable | Single-winding latching | Double-winding latching |
|--------------|---------------------|-------------------------|--------------------|-------------------------|-------------------------|
| SPDT         | Bifurcated crossbar | Straight terminal       | G6E-134P-US        | G6EU-134P-US            | G6EK-134P-US            |
|              |                     | Self-clinching terminal | G6E-134C-US        | G6EU-134C-US            | G6EK-134C-US            |

**Note:** When ordering, add the rated coil voltage to the model number.  
 Example: G6E-134P-US 12 VDC

\_\_\_\_\_ Rated coil voltage

### Model Number Legend

G6E   -           -   -     VDC

1    2    3    4    5    6    7    8    9

#### 1. Relay Function

None: Single-side stable  
 U: Single-winding latching  
 K: Double-winding latching

#### 2. Contact Form

1: SPDT

#### 3. Contact Type

3: Bifurcated crossbar  
 Ag (Au-clad) contact  
 9: Bifurcated crossbar  
 AgNi (Au-clad) contact

#### 4. Enclosure Ratings

4: Fully sealed

#### 5. Terminals

P: Straight PCB  
 C: Curved tail

#### 6. Special Function

L: Low sensitivity coil (400 mW)

#### 7. Approved Standards

US: UL, CSA certified

#### 8. Special Function

U: For ultrasonically cleanable

#### 9. Rated Coil Voltage

3, 5, 6, 9, 12, 24, 48 VDC

## Specifications

### ■ Coil Ratings

#### Single-side Stable, Bifurcated Crossbar Contact Type

|                             |                               |       |         |         |         |         |                               |
|-----------------------------|-------------------------------|-------|---------|---------|---------|---------|-------------------------------|
| <b>Rated voltage</b>        | 3 VDC                         | 5 VDC | 6 VDC   | 9 VDC   | 12 VDC  | 24 VDC  | 48 VDC                        |
| <b>Rated current</b>        | 66.7 mA                       | 40 mA | 33.3 mA | 22.2 mA | 16.7 mA | 8.3 mA  | 8.3 mA                        |
| <b>Coil resistance</b>      | 45 Ω                          | 125 Ω | 180 Ω   | 405 Ω   | 720 Ω   | 2,880 Ω | 5,760 Ω                       |
| <b>Coil inductance</b>      | <b>Armature OFF</b>           | 0.08  | 0.18    | 0.31    | 0.62    | 1.20    | 4.70                          |
| <b>(H) (ref. value)</b>     | <b>Armature ON</b>            | 0.06  | 0.17    | 0.24    | 0.50    | 0.99    | 3.90                          |
| <b>Must operate voltage</b> | 70% max. of rated voltage     |       |         |         |         |         |                               |
| <b>Must release voltage</b> | 10% min. of rated voltage     |       |         |         |         |         |                               |
| <b>Max. voltage</b>         | 190% of rated voltage at 23°C |       |         |         |         |         | 170% of rated voltage at 23°C |
| <b>Power consumption</b>    | Approx. 200 mW                |       |         |         |         |         | Approx 400 mW                 |

#### Single-winding Latching, Bifurcated Crossbar Contact Type

|                           |                               |       |         |         |         |         |
|---------------------------|-------------------------------|-------|---------|---------|---------|---------|
| <b>Rated voltage</b>      | 3 VDC                         | 5 VDC | 6 VDC   | 9 VDC   | 12 VDC  | 24 VDC  |
| <b>Rated current</b>      | 66.7 mA                       | 40 mA | 33.3 mA | 22.2 mA | 16.7 mA | 8.3 mA  |
| <b>Coil resistance</b>    | 45 Ω                          | 125 Ω | 180 Ω   | 405 Ω   | 720 Ω   | 2,880 Ω |
| <b>Coil inductance</b>    | <b>Armature OFF</b>           | 0.05  | 0.13    | 0.19    | 0.45    | 0.84    |
| <b>(H) (ref. value)</b>   | <b>Armature ON</b>            | 0.04  | 0.12    | 0.17    | 0.40    | 0.79    |
| <b>Must set voltage</b>   | 70% max. of rated voltage     |       |         |         |         |         |
| <b>Must reset voltage</b> | 70% max. of rated voltage     |       |         |         |         |         |
| <b>Max. voltage</b>       | 190% of rated voltage at 23°C |       |         |         |         |         |
| <b>Power consumption</b>  | Approx. 200 mW                |       |         |         |         |         |

#### Double-winding Latching, Bifurcated Crossbar Contact Type

|                           |  |                     |       |         |         |         |
|---------------------------|--|---------------------|-------|---------|---------|---------|
| <b>Rated voltage</b>      | 3 VDC  | 5 VDC               | 6 VDC | 9 VDC   | 12 VDC  | 24 VDC  |
| <b>Set Coil</b>           | <b>Rated current</b>                                   | 66.7 mA             | 40 mA | 33.3 mA | 22.2 mA | 16.7 mA |
|                           | <b>Coil resistance</b>                                 | 45 Ω                | 125 Ω | 180 Ω   | 405 Ω   | 720 Ω   |
|                           | <b>Coil inductance</b>                                 | <b>Armature OFF</b> | 0.03  | 0.09    | 0.12    | 0.25    |
|                           | <b>(H) (ref. value)</b>                                | <b>Armature ON</b>  | 0.03  | 0.08    | 0.11    | 0.22    |
| <b>Reset Coil</b>         | <b>Rated current</b>                                   | 66.7 mA             | 40 mA | 33.3 mA | 22.2 mA | 16.7 mA |
|                           | <b>Coil resistance</b>                                 | 45 Ω                | 125 Ω | 180 Ω   | 405 Ω   | 720 Ω   |
|                           | <b>Coil inductance</b>                                 | <b>Armature OFF</b> | 0.03  | 0.09    | 0.12    | 0.25    |
|                           | <b>(H) (ref. value)</b>                                | <b>Armature ON</b>  | 0.03  | 0.08    | 0.11    | 0.22    |
| <b>Must set voltage</b>   | 70% max. of rated voltage                              |                     |       |         |         |         |
| <b>Must reset voltage</b> | 70% max. of rated voltage                              |                     |       |         |         |         |
| <b>Max. voltage</b>       | 190% of rated voltage (at 23°C)                        |                     |       |         |         |         |
| <b>Power consumption</b>  | Set coil: Approx. 200 mW<br>Reset coil: Approx. 200 mW |                     |       |         |         |         |

**Note:** 1. The rated current and coil resistance are measured at a coil temperature of 23°C with a tolerance of ±10%.  
2. Operating characteristics are measured at a coil temperature of 23°C.

## ■ Contact Ratings

|                                       |                                   |   |
|---------------------------------------|-----------------------------------|---|
| <b>Load</b>                           | Resistive load ( $\cos\phi = 1$ ) | Inductive load ( $\cos\phi = 0.4$ ; L/R = 7 ms) |
| <b>Rated Load</b>                     | 0.4 A at 125 VAC; 2 A at 30 VDC   | 0.2 A at 125 VAC; 1 A at 30 VDC                 |
| <b>Contact Material</b>               | Ag (Au-clad)                      |   |
| <b>Rated Carry Current</b>            | 3 A                               |   |
| <b>Max. switching voltage</b>         | 250 VAC, 220 VDC                  |   |
| <b>Max. switching current</b>         | 3 A                               | 3 A   |
| <b>Max. switching power</b>           | 50 VA, 60 W                       | 25 VA, 30 W                                     |
| <b>Failure rate (reference value)</b> | 10 $\mu$ A at 10m VDC             |   |

Note: P level:  $\lambda_{60} = 0.1 \times 10^{-6}$ /operation.

## ■ Characteristics

|                                     |   |
|-------------------------------------|---|
| <b>Contact resistance</b>           | 50 m $\Omega$ max.  |
| <b>Operate (set*) time</b>          | 5 ms max. (mean value: approx. 2.9 ms; 48 VDC type: approx. 2.4 ms)   |
| <b>Release (reset*) time</b>        | 5 ms max. (mean value: approx. 1.3 ms)  |
| <b>Bounce time</b>                  | Operate: 3 ms max. (mean value: 0.37 ms)<br>Release: 3 ms max. (mean value: 1.12 ms)  |
| <b>Max. operating frequency</b>     | Mechanical: 36,000 operations/hr<br>Electrical: 1,800 operations/hr (under rated load)  |
| <b>Insulation resistance</b>        | 1,000 M $\Omega$ min. (at 500 VDC)  |
| <b>Dielectric withstand voltage</b> | 1,500 VAC, 50/60 Hz for 1 min between coil and contacts<br>1,000 VAC, 50/60 Hz for 1 min between contacts of same polarity  |
| <b>Impulse withstand voltage</b>    | 1,500 V (10 x 160 $\mu$ s) (conforms to FCC Part 68)  |
| <b>Vibration resistance</b>         | Destruction: 10 to 55 to 10 Hz, 2.5mm single amplitude (5mm double amplitude)<br>Malfunction: 10 to 55 to 10 Hz, 1.65mm single amplitude (3.3mm double amplitude)   |
| <b>Shock resistance</b>             | Destruction: 1,000 m/s <sup>2</sup><br>Malfunction: 300 m/s <sup>2</sup>  |
| <b>Endurance</b>                    | Mechanical: 100,000,000 operations min. (at 36,000 operations/hr)<br>Electrical: 100,000 operations min. (0.4 A at 125 VAC resistive load; 0.2 A at 125 VAC inductive load)<br>500,000 operations min. (2 A at 30 VDC resistive load; 1 A at 30 VDC inductive load)<br>200,000 operations min. (3 A at 30 VDC resistive load) |
| <b>Ambient temperature</b>          | Operating: -40°C to 70°C (with no icing)  |
| <b>Ambient humidity</b>             | 5% to 85%   |
| <b>Weight</b>                       | Approx. 2.7 g   |

\*Minimum set and reset signals width is 7 ms min.

## ■ Approved Standards

UL508 (File No. E41515)/CSA C22.2, No.14 (File No. LR31928)

| Contact form | Coil ratings | Contact ratings  |
|--------------|--------------|--|
| SPDT         | 3 to 48 VDC  | 0.2 A, 250 VAC (general use)<br>0.6 A, 125 VAC (general use)<br>2 A, 30 VDC (resistive)<br>0.6 A, 125 VDC (resistive, Ag contact only) |

## Engineering Data

### Maximum Switching Power

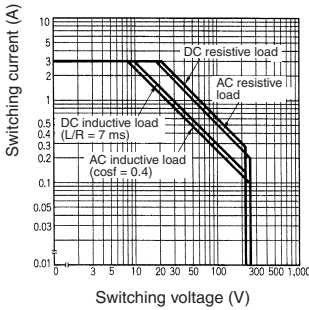

### Endurance

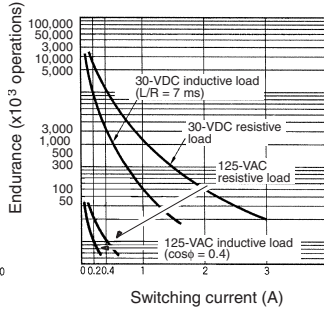

### Ambient Temperature vs. Maximum Coil Voltage

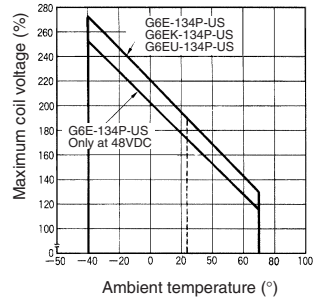

**Note:** The maximum coil voltage refers to the maximum value in a varying range of operating power voltage, not a continuous voltage.

## Dimensions

**Note:** 1. All units are in millimeters unless otherwise indicated.

2. Orientation marks are indicated as follows:

### G6E-134P-US G6E-194P-US

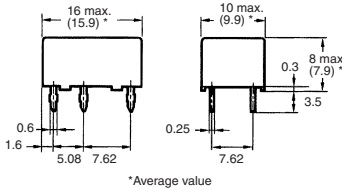

### Terminal Arrangement/ Internal Connections (Bottom View)

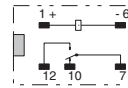

### G6E-194C-US

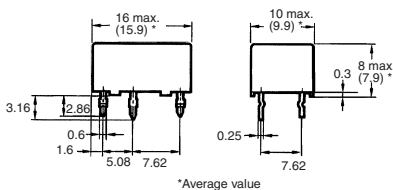

### Mounting Holes (Bottom View) Tolerance: ±0.1

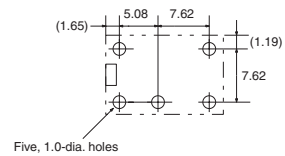

### G6EU-134P-US G6EU-194P-US

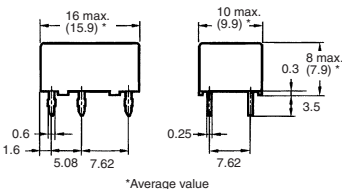

### Terminal Arrangement/ Internal Connections (Bottom View)

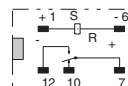

### Mounting Holes (Bottom View)

## G6EU-134C-US G6EU-194C-US

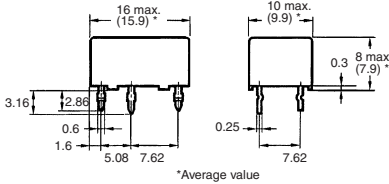

### Mounting Holes (Bottom View) Tolerance: $\pm 0.1$

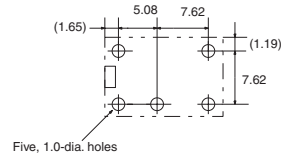

## G6EK-134P-US G6EK-194P-US

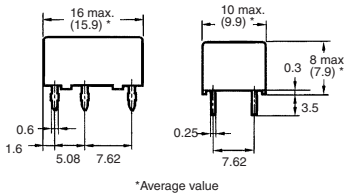

### Terminal Arrangement/ Internal Connections (Bottom View)

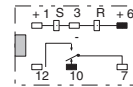

### Mounting Holes (Bottom View) Tolerance: $\pm 0.1$

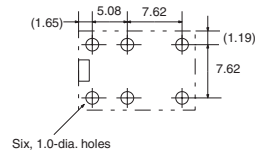

## G6EK-134C-US G6EK-194C-US

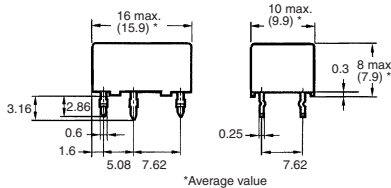
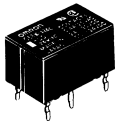

## Precautions

### ■ Precautions for Correct Use

#### Long-term Continuously ON Contacts

Using the Relay in a circuit where the Relay will be ON continuously for long periods (without switching) can lead to unstable contacts because the heat generated by the coil itself will affect the insulation, causing a film to develop on the contact surfaces. We recommend using a latching relay (magnetic-holding relay) in this kind of circuit. If a single-side stable model must be used in this kind of circuit, we recommend using a fail-safe circuit design that provides protection against contact failure or coil burnout.

#### Installation

Do not reverse the polarity of the coil (+, -).

Provide sufficient space between Relays when mounting two or more on the same PCB, as shown in the following diagram.

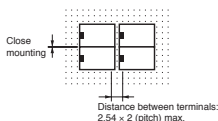

#### Wiring

Refer to the following diagram when wiring to switch a DC load. The difference in polarity applied to the contacts will affect the endurance of the Relay due to the amount of contact movement. To extend the endurance characteristics beyond the performance ratings, wire the common (pin 7) terminal to the positive (+) side.

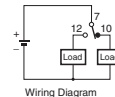

#### Ultrasonic Cleaning

Do not use ultrasonic cleaning on standard relay models. Doing so may result in resonance, coil burnout, and contact adhesion within the Relay. Use a model designed for ultrasonic cleaning if ultrasonic cleaning is required.

#### Relay Handling

When washing the product after soldering the Relay to a PCB, use a water-based solvent or alcohol-based solvent, and keep the solvent temperature to less than 40°C. Do not put the Relay in a cold cleaning bath immediately after soldering.