

MOTOR REGULATOR AND BIAS/ERASE OSCILLATOR CIRCUIT

The TDA1003A is pin for pin compatible with the TDA1003 with an extension of features. The TDA1003A is for use in recording/playback systems. It incorporates capstan motor speed control, an automatic stop circuit, and a bias/erase oscillator.

The motor circuit controls the back e. m. f. and delivers a stabilized voltage to the capstan motor. The motor voltage is corrected for line voltage and torque variations, and temperature variations of the magnetic material and windings. The motor speed control is operative as long as a pulse train, derived from the tape wind spool mechanism via an interrupter, is applied to the automatic stop circuit. The TDA1003A can also be used without stop circuit by connecting pin 16 to ground. An output is available for a "stop" indicator lamp.

The oscillator section contains a temperature-independent voltage reference source and an a. g. c. circuit controlling the transconductance of a balanced oscillator circuit incorporating the erase head. Any Q variations of the erase head winding are fed back to maintain the oscillator output as a constant undistorted sine-wave so that harmonic products do not cause interference during radio recording.

QUICK REFERENCE DATA			
Supply voltage range	V_p	3,5 to 18	V
Ambient temperature	T_{amb}	typ.	25 °C
Supply voltage	V_p	typ.	9 V

Motor regulator			
Current consumption	I_4	typ.	1,8 mA
Motor starting current	I_3	<	1000 mA
Operating motor current	I_3	<	250 mA
Minimum operating voltage at $I_3 = 600$ mA	V_{3-2min}	typ.	0,9 V
Supply voltage rejection	$\Delta V_{3-2}/\Delta V_{4-2}$	typ.	1 mV/V
Stop circuit			
Output current for "stop" indicator lamp	I_1	<	100 mA
Knee voltage at $I_1 = 100$ mA	V_{1-2}	typ.	0,6 V
Input current for $I_1 = 100$ mA	I_{16}	>	4 μ A
Bias and erase oscillator			
Current consumption at $Q = 40$	I_8	typ.	25 mA
Erase head voltage at $Q = 40$ (r. m. s. value)	$V_{erase(rms)}$	typ.	16 V

PACKAGE OUTLINE

16-lead DIL: plastic power (SOT-38N).

CIRCUIT DIAGRAM

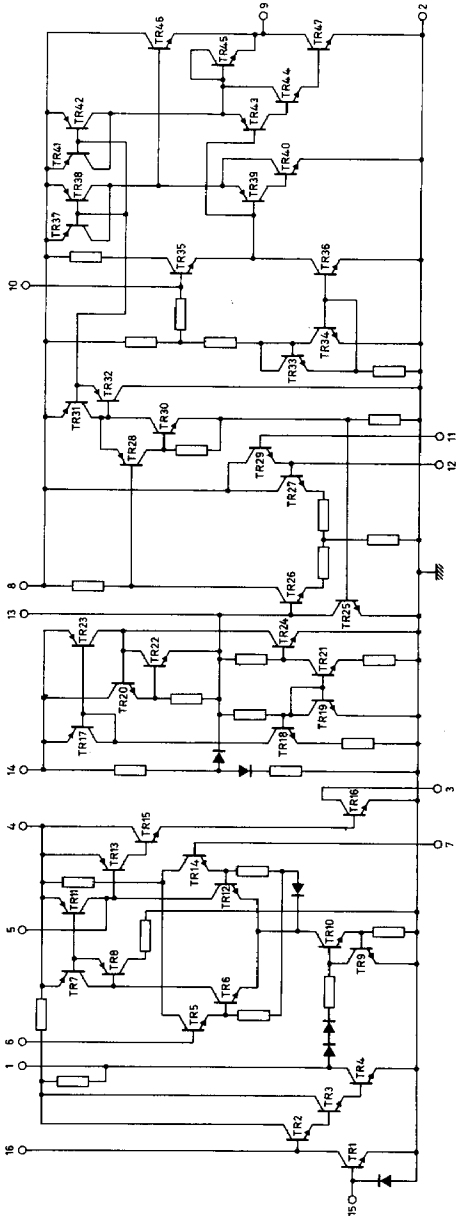

RATINGS Limiting values in accordance with the Absolute Maximum System (IEC 134)

Voltages

Supply voltage on: pin 4	V_{4-2}	max.	18	V
pin 8	V_{8-2}	max.	18	V
pin 14	V_{14-2}	max.	18	V

Currents

Motor current (pin 3: peak-value)	I_{3M}	max.	1000	mA
"Stop" indicator lamp current (d. c. : pin 1)	I_1	max.	100	mA
Maximum input current (pin 15)	$\pm I_{15 \max}$	max.	20	mA

Temperatures

Storage temperature	T_{stg}	-65 to +150	°C
Operating ambient temperature see also power derating curve below	T_{amb}	-20 to +150	°C

Power dissipation

Total power dissipation see derating curve below

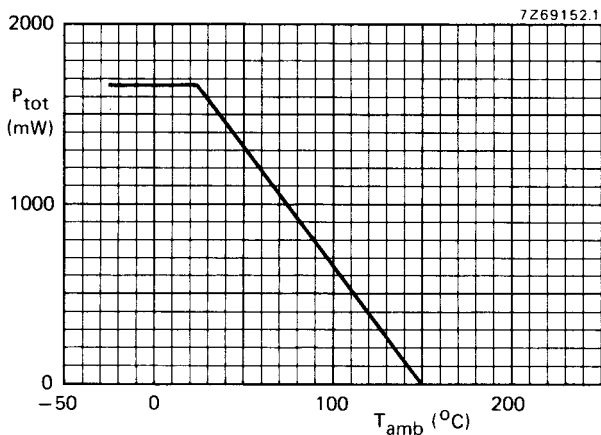

CHARACTERISTICS at $V_p = 9\text{ V}$; $T_{\text{amb}} = 25\text{ }^\circ\text{C}$ unless otherwise specified; see test circuit on page 6

Supply voltage range (pins 4, 8 and 14) V_p 3, 5 to 18 V 1)

Motor regulator

Current consumption	I_4	typ.	1, 8 mA 1 to 3 mA
Operating motor current	I_3	<	250 mA
Motor starting current (peak-value)	I_{3M}	<	1000 mA
Input offset voltage at $I_3 = 3\text{ mA}$	$ V_{7-6} $	typ. <	2 mV 8 mV
Input offset current at $I_3 = 3\text{ mA}$	$ I_{7-6} $	typ.	0, 2 μA
Input voltage range (common mode)	V_{6-2} V_{7-2}	2, 4 to ($V_p - 0, 25$)	V V
Input bias current	$I_6; I_7$	typ. <	0, 1 μA 1, 0 μA
Input sensitivity (for $\Delta I_3 = 100\text{ mA}$)	ΔV_{7-6}	typ. <	1 mV 10 mV
Minimum operating voltage at $I_3 = 600\text{ mA}$	$V_{3-2\text{ min}}$	typ. <	0, 9 V 1, 8 V 2)

Automatic motor "stop" circuit

"Stop" indicator lamp current	I_1	<	100 mA
Knee voltage at $I_1 = 100\text{ mA}$	V_{1-2}	typ. <	0, 6 V 1, 0 V
Input current for $I_1 = 100\text{ mA}$	I_{16}	>	4 μA
Voltage at pin 1 without external load ($V_{16} = \text{low}$)	V_{1-2}	typ.	4, 1 V 3 to 5, 0 V
Maximum input current (pin 15)	$\pm I_{15\text{ max}}$	<	20 mA

1) To guarantee proper functioning with $V_p = 3, 5\text{ V}$ to 18 V , the external component values as shown in test circuit on page 6 should be modified.

2) The minimum operating voltage is defined as the voltage (V_{3-2}) at which the motor still operates at correct speed.

CHARACTERISTICS (continued)

Bias and erase oscillator

Current consumption at $Q = 40$	I_8	typ.	25	mA
at $Q = 20$	I_8	{ typ. <	38 46	mA
Internal current limiting	I_8	<	95	mA ¹⁾
Peak output current	$\pm I_9$	>	100	mA
Output voltage swing (peak-to-peak value)	$V_{9-2(p-p)}$	typ.	V_{p-2}	V
Current consumption of reference source	I_{14}	typ. <	1,8 2,4	mA
Reference voltage (temperature compensated) ²⁾	V_{13-2}	typ.	1,7	V
Erase head voltage: $Q = 40; L = 620 \mu\text{H}$ (r. m. s. value)	$V_{\text{erase}(rms)}$	typ.	16	V
Change of V_{erase} when Q changes from 20 to 60	ΔV_{erase}	typ. <	1 1,8	V

APPLICATION INFORMATION measured in circuit on page 7

Motor regulator

Supply voltage rejection	$\frac{\Delta V_{3-2}}{\Delta V_{4-2}}$	typ.	1	mV/V
Motor speed variation over $T_{\text{amb}} = -5$ to $+55$ °C	$\pm \Delta n$	typ.	2	%

Automatic motor "stop" circuit

Input voltage from wind spool supplied via 10 k Ω to pin 15 (peak-to-peak value)	$V_{W(p-p)}$	typ.	1,2	V
Input current (pin 15)	$\pm I_{15}$	<	20	mA

Bias and erase oscillator

Erase head voltage for $Q = 40$: $L = 620 \mu\text{H}$ (r. m. s. value)	$V_{\text{erase}(rms)}$	typ.	16	V
Change of V_{erase} when Q changes from 20 to 60	ΔV_{erase}	typ.	1	V
Harmonic distortion (unsaturated erase head)	$-\alpha_{2nd\text{harm}}$	typ.	55	dB ³⁾
	$-\alpha_{3rd\text{harm}}$	typ.	40	dB
	$-\alpha_{>6\text{thharm}}$	>	80	dB

¹⁾ If erase head is defective.

²⁾ Typical value of temperature coefficient 0 mV/°C.

³⁾ At unsaturated erase head, with respect to 45 kHz.

TEST CIRCUIT

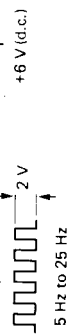
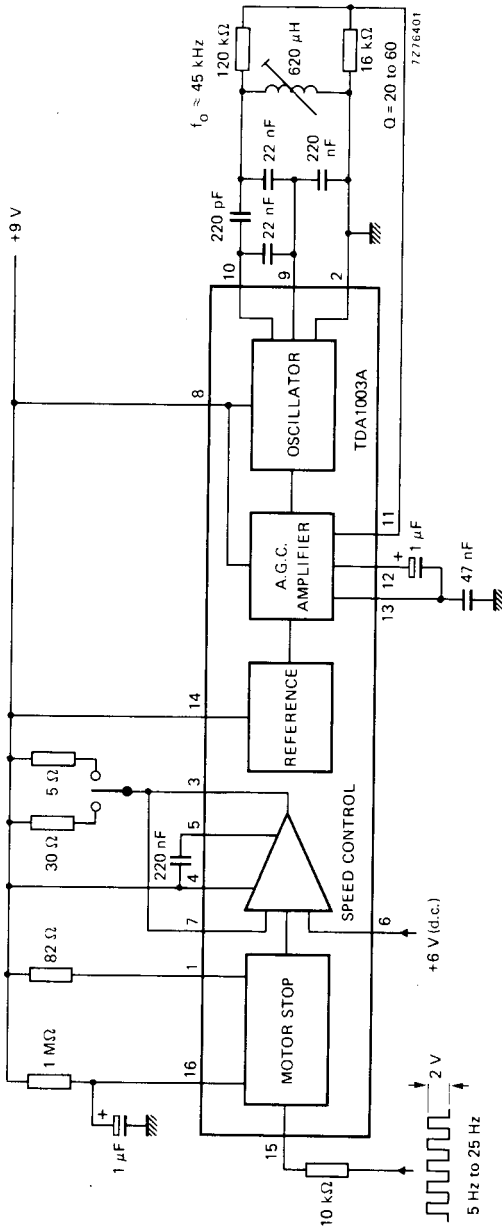

188

