

**STRAIGHT PLUG RECEPTACLE FOR PCB
SOLDER LEGS**

R114.426.000

Series : SMB

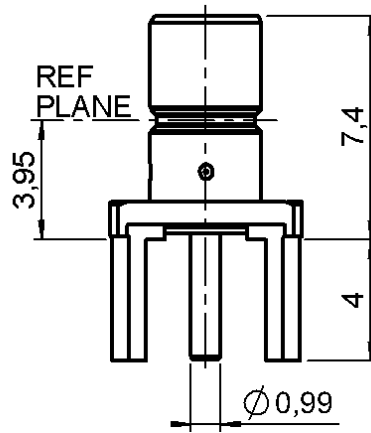
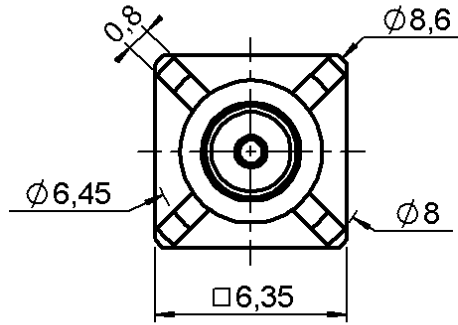

PANEL CUT OUT

mm		
	Maxi	mini
A	1.4	1.3
B	5.13	5.03

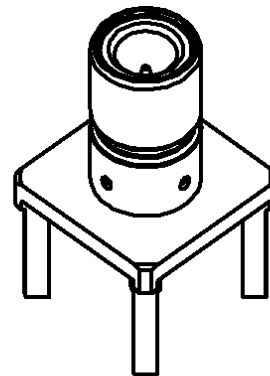
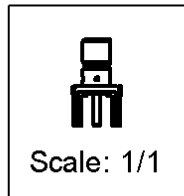

All dimensions are in mm.

COMPONENTS	MATERIALS	PLATINGS (µm)
BODY	BRASS	GOLD 0.2 OVER NICKEL 2
CENTER CONTACT	BRASS	GOLD 1.3 OVER NICKEL 2
OUTER CONTACT	-	-
INSULATOR	PTFE	-
GASKET	-	-
OTHERS PARTS	-	-
-	-	-
-	-	-

Issue : 0214 B

In the effort to improve our products, we reserve the right to make changes judged to be necessary.



STRAIGHT PLUG RECEPTACLE FOR PCB

R114.426.000

SOLDER LEGS

Series : SMB

PACKAGING

SPECIFICATION

Standard	Unit	Other
100	'W' option	Contact us

ELECTRICAL CHARACTERISTICS

ENVIRONMENTAL

Impedance		50 Ω
Frequency		0-4 GHz
VSWR	1.05 +	0.008 x F(GHz) Maxi
Insertion loss		0.03* √F(GHz) dB Maxi
RF leakage	- (57 - F(GHz)) dB Maxi
Voltage rating		500 Veff Maxi
Dielectric withstanding voltage		1000 Veff mini
Insulation resistance		1000 MΩ mini

Operating temperature	-65/+165 ° C
Hermetic seal	NA Atm.cm3/s
Panel leakage	NA

OTHERS CHARACTERISTICS

Assembly instruction **NA**

Others :

* Coaxial Transmission Line Only

MECHANICAL CHARACTERISTICS

Center contact retention	
Axial force – Mating end	10 N mini
Axial force – Opposite end	10 N mini
Torque	NA N.cm mini
Recommended torque	
Mating	NA N.cm
Panel nut	NA N.cm
Mating life	500 Cycles mini
Weight	0.700 g

Issue : 0214 B

In the effort to improve our products, we reserve the right to make changes judged to be necessary.

