

# MODEL 67

## 3/8" Square

### Multiturn

### Cermet Trimming

### Potentiometer

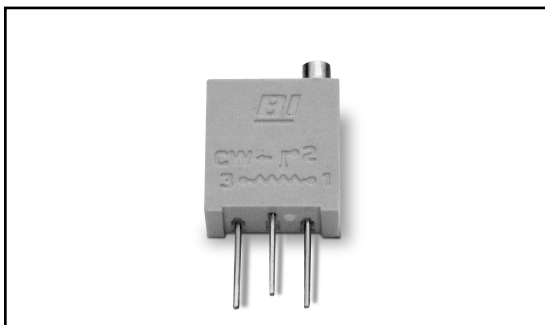

#### ELECTRICAL

Standard Resistance Range, Ohms	10 to 2Meg
Standard Resistance Tolerance	±10% (<100 Ohms = ±20%)
Input Voltage, Maximum	200 Vdc or rms not to exceed power rating
Slider Current, Maximum	100mA or within rated power, whichever is less
Power Rating, Watts	0.5 at 85°C derating to 0 at 125°C
End Resistance, Maximum	2 Ohms
Actual Electrical Travel, Turns, Nominal	20
Dielectric Strength	900 Vrms
Insulation Resistance, Minimum	1,000 Megohms
Resolution	Essentially infinite
Contact Resistance Variation, Maximum	1% or 1 Ohm, whichever is greater

#### ENVIRONMENTAL

Seal	85°C Fluorinert® (No Leaks)
Temperature Coefficient, Maximum	±100ppm/°C (<100 Ohms = ±250ppm/°C)
Temperature Range	-55°C to +125°C
Thermal Shock	5 cycles, -55°C to +125°C (1% ΔRT, 1% ΔVR)
Moisture Resistance	Ten 24 hour cycles (1% ΔRT, IR 1,000 Megohms min.)
Shock, 6ms Sawtooth	100G's (1% ΔRT, 1% ΔVR)
Vibration	20G's, 10 to 2,000 Hz (1% ΔRT, 1% ΔVR)
High Temperature Exposure	250 hours at 125°C (2% ΔRT, 2% ΔVR)
Rotational Life	200 cycles (3% ΔRT)
Load Life at 0.5 Watts	1,000 hours at 70°C (2% ΔRT)
Resistance to Solder Heat	260°C for 10 sec. (1% ΔRT)

#### MECHANICAL

Mechanical Stops	Clutch Action, both ends
Torque, Starting Maximum	5 oz.-in. (0.035 N-m)
Weight, Nominal	.04 oz. (1.13 grams)

Fluorinert® is a registered trademark of 3M Company.  
Specifications subject to change without notice.

## TOP ADJUSTMENT (Inch/mm)

Model 67W and 67Y

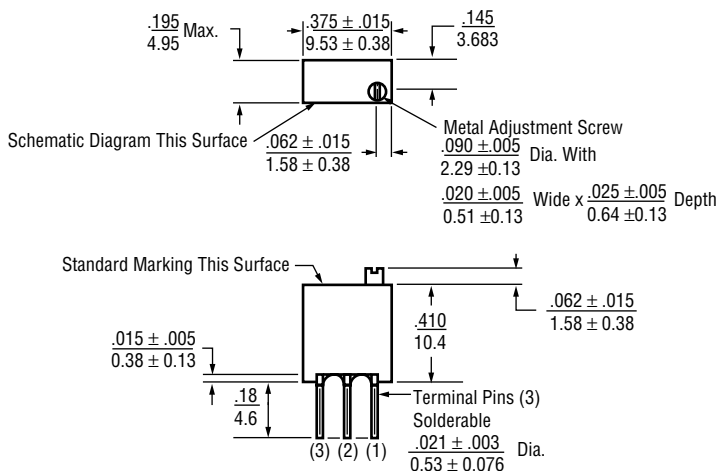

Model 67W

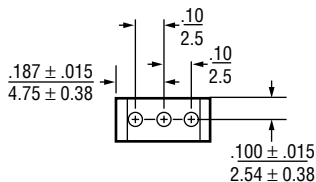

Model 67Y

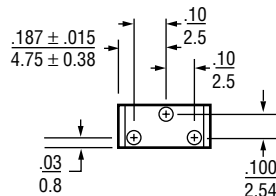

## STANDARD RESISTANCE VALUES, OHMS

10	200	5K	50K	500K
20	500	10K	100K	1Meg
50	1K	20K	200K	2Meg
100	2K	25K	250K	

**SIDE ADJUSTMENT (Inch/mm)**

**Model 67X and 67Z**

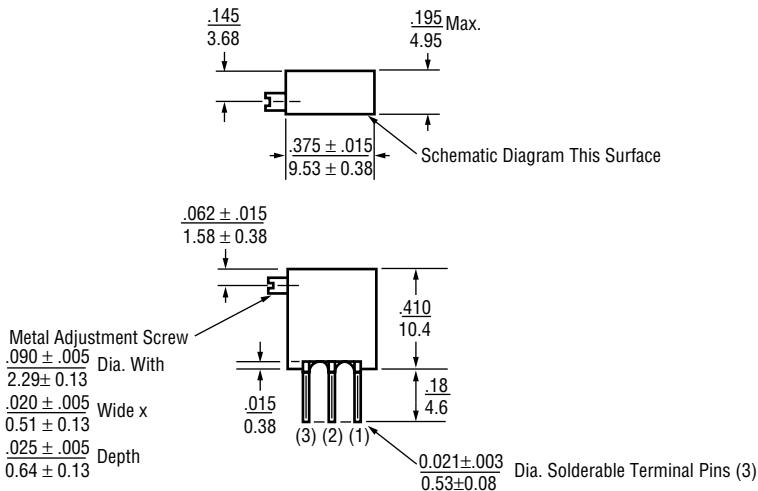

**Model 67X**

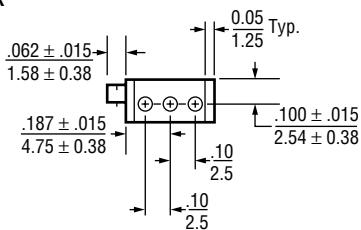

**Model 67Z**

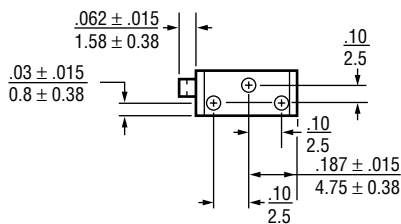

**SIDE ADJUSTMENT (Inch/mm)**

**Model 67P**

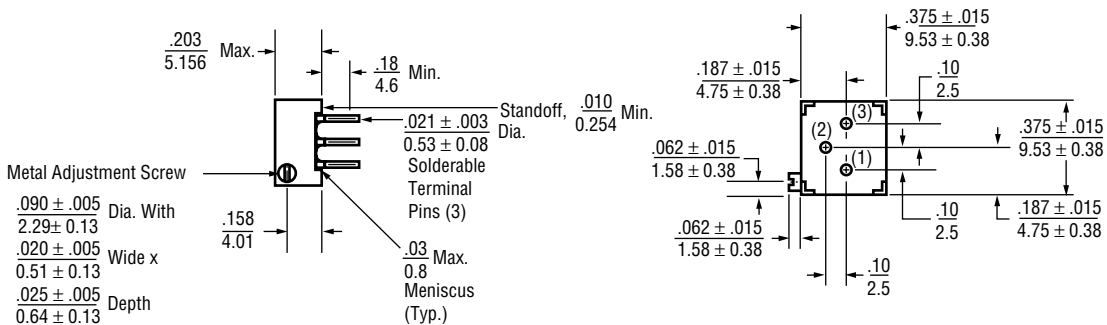

## PACKAGING

**Standard:** Boxes

Capacity	=	100 Units (67W)
	=	50 Units (All other styles)

**Option:** Tubes

All units oriented with #1 pin to same side.

	Pin Style		P	W, Y	X, Z
Magazine	Width	=	0.57"	0.28"	0.28"
	Height	=	0.66"	0.93"	0.93"
	Length	=	20.9"	20.6"	24.4"
	Capacity	=	50 Units	50 Units	50 Units

**Option:** Tape & Reel, Ammo Pack (Available only for 67W and 67X)

All units oriented with #1 pin to the right of the direction of feed.

	Seat Plane to Centerline of Sprocket Hole	=	.71" (18.03 mm)
Tape	Width	=	18 mm
	Sprocket	=	Single Hole .50" spacing
	Capacity	=	1,000 Units
Reel	Diameter	=	14" (363 mm)
Ammo	Tape Fold	=	12" (305 mm)
	Box	=	1.8" x 13" x 10" (46mm x 330mm x 254mm)

**ORDERING INFORMATION**

**Standard:**

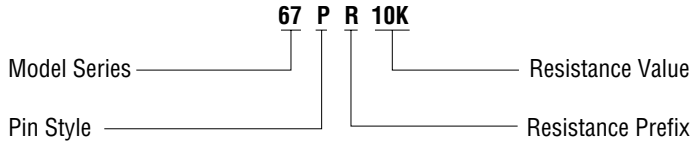

**Option:**

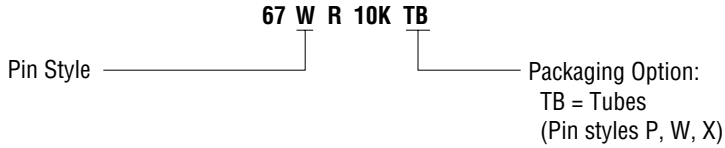

**Option:**

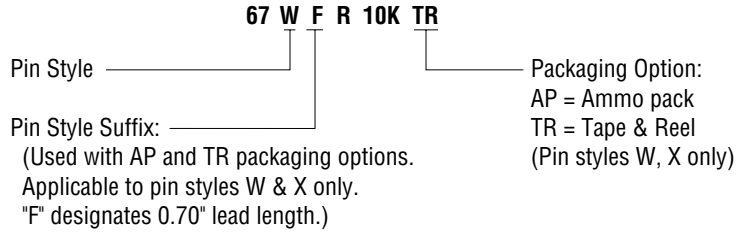

**CIRCUIT DIAGRAM**

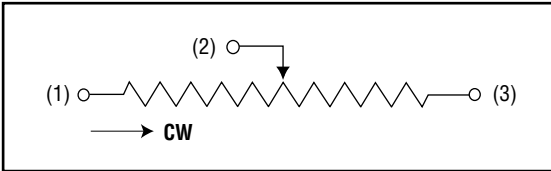

**NOTES**

Metric equivalents, based on 1 inch = 25.4mm are rounded to the same number of significant figures as in the original English units and are provided for general information only.

Tolerances unless otherwise specified:  
 Linear = ± .01 inches (.25mm)  
 Angular = ± 2 degrees

