

**PROPER USE GUIDELINES**

Cumulative Trauma Disorders can result from the prolonged use of manually powered hand tools. Hand tools are intended for occasional use and low volume applications. A wide selection of powered application equipment for extended-use, production operations is available.

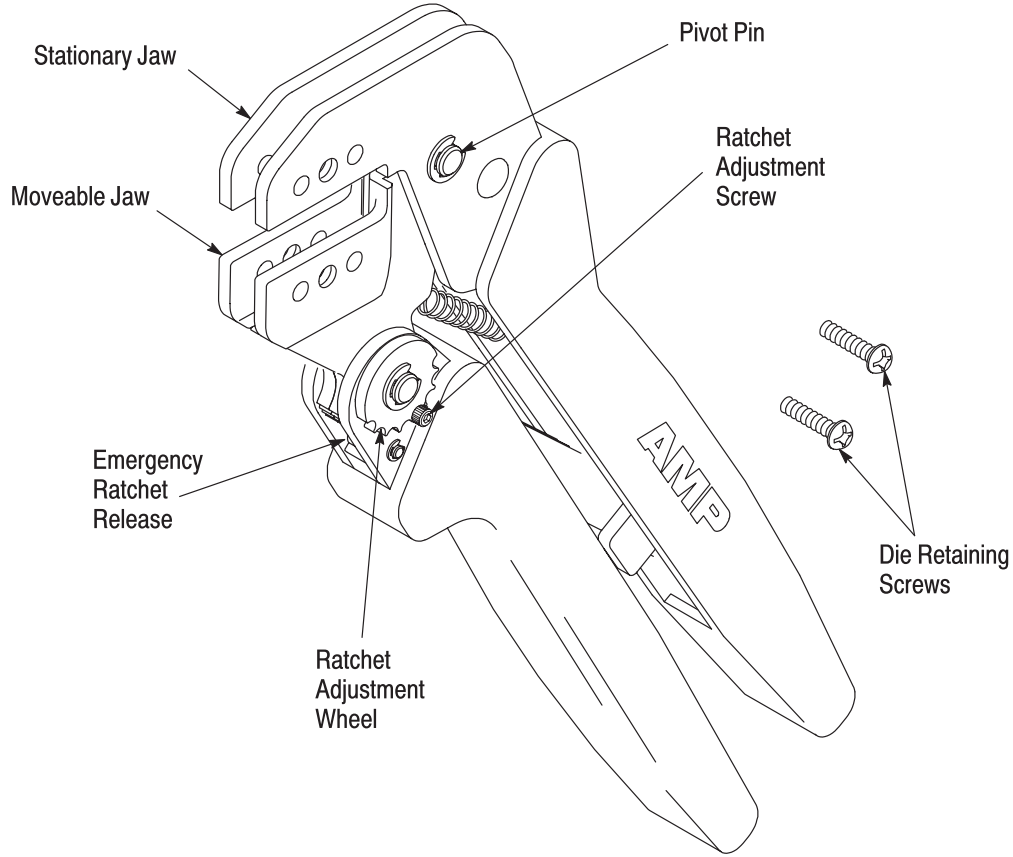

Figure 1

**1. INTRODUCTION**

This instruction sheet provides application and maintenance procedures for the PRO-CRIMPER III Hand Crimping Tool Frame Assembly 354940-1. See Figure 1. The tool is designed to accept interchangeable crimping die assemblies for crimping various types of Tyco Electronics Connectors.

In most cases, the PRO-CRIMPER III tool frame assembly is provided with a specific set of dies and is considered a component part of a crimping assembly. Refer to the appropriate instruction sheet packaged with the hand tool/crimping die assembly, or with the separate die assembly, for information regarding crimping procedures, crimp height inspection, and crimping die gaging.

Read these instructions thoroughly before installing dies and using the tool.



*The PRO-CRIMPER III Frame Assembly is designed to accept dies to crimp a variety of Tyco Electronics products. Contact your local Tyco Electronics Representative or the Tooling Assistance Center for information regarding the availability of dies for specific applications.*



*All dimensions on this document are in metric units [with U. S. customary units in brackets]. Figures and illustrations are for reference only and are not drawn to scale.*

Reason for revision is given in Section 7, REVISION SUMMARY.

**2. DESCRIPTION**

The PRO-CRIMPER III tool consists of two crimping jaws, an adjustable ratchet, spring-actuated handles, two die retaining screws, and an emergency ratchet

release. The slotted design of the crimping jaws permits easy installation and removal of crimping dies. The adjustable ratchet allows handle pressure to be set for optimum crimping die performance.

**3. DIE INSTALLATION AND REMOVAL**

Select the desired die assembly, remove the die retention screws from the tool jaws, and proceed as follows:

**3.1. Shouldered Dies (Figure 2)**

1. Place the upper die in the stationary jaw of the tool frame.

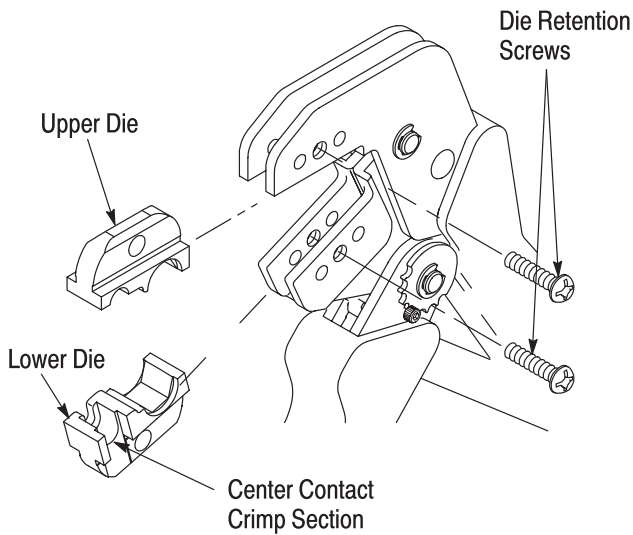

Figure 2

2. Insert a die retention screw through the jaw and die and tighten the screw so that the die is held in place, but do not tighten the screw completely at this point.



Die assemblies with center contact crimp sections should be installed with the center contact crimp section toward the front of the tool jaws as shown in Figure 2. If indicated otherwise in other instructions, follow the specific die requirements demonstrated in that document.

3. Place the lower die in the moving jaw of the tool frame. Install a die retention screw through the jaw and die and tighten the screw so that the die is held in place, but do not tighten the screw completely at this point.



The PRO-CRIMPER III tool ratchet has detents that are audible as seven “clicks” as the handles are closed. The ratchet releases on the seventh “click”.

4. Slowly close the tool handles, allowing the dies to mate and/or align. Continue closing the tool handles until the ratchet makes the sixth “click,” then tighten both die retention screws until snug.

5. To remove the die assembly, close the tool handles until the ratchet releases, and allow the handles to open fully. Loosen and remove the die retention screws and slide the dies out of the tool jaws.

**3.2. Pinned Dies (Figure 3)**

1. Install the wire and insulation anvil dies, with the chamfers facing the front of the tool, and with the die markings facing outward, into the movable jaw of the frame assembly.

2. Insert the die retaining pins and the short die retention screw. Do not tighten the screw completely.

3. Install the wire and insulation crimping dies, with the chamfers facing the front of the tool, and with the die markings facing outward, into the stationary jaw of the frame assembly.

4. Insert the die retaining pins the long die retention screw. Do not tighten the screw completely.

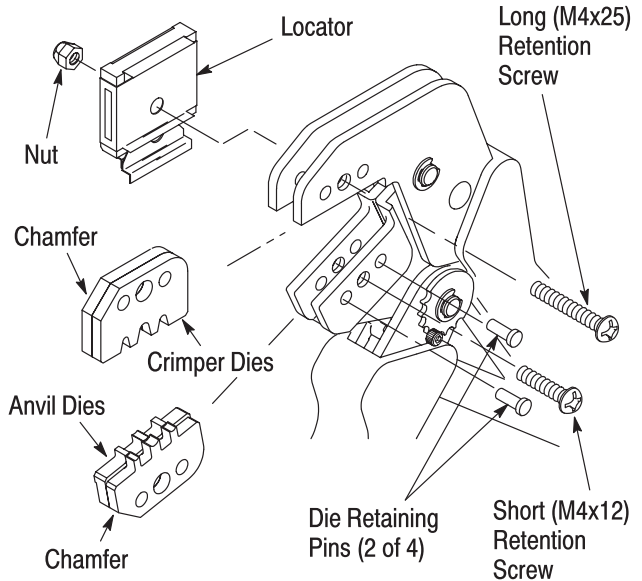

Figure 3

5. Slowly close the tool handles, allowing the dies to mate and/or align. Continue closing the tool handles until the ratchet makes the sixth “click,” then tighten both die retention screws until snug.

6. Install the locator assembly and tighten the hex nut.

7. Reverse the procedure to remove the die assembly.

## 4. MAINTENANCE/INSPECTION

### 4.1. Daily Maintenance

Tyco Electronics recommends that operators of the tool be made aware of, and responsible for, the following steps of daily maintenance:

1. Remove dust, moisture, and any other contaminants from the tool with a clean, soft brush, or a clean, soft, lint-free cloth. Do NOT use hard or abrasive objects that could damage the tool.
2. Make certain that the pivot pins are in place and that they are secured with retaining rings.
3. All pins, pivot points, and bearing surfaces should be protected with a thin coat of any good SAE No. 20 motor oil. Do not oil excessively.
4. When the tool is not in use, keep handles closed to prevent objects from becoming lodged in the crimping jaws. Store the tool in a clean, dry area.

### 4.2. Periodic Inspection

Regular inspections of the tool should be performed by quality control personnel. A record of scheduled inspections should remain with the tool or be supplied to supervisory personnel responsible for the tool. Inspection frequency should be based upon amount of use, working conditions, operator training and skill, and established company standards.

1. Remove all lubrication and accumulated film by immersing the tool (handles partially closed) in a suitable commercial degreaser that will not affect paint or plastic material.
2. Make certain that all pivot pins are in place and secured with retaining rings.
3. Close tool handles until ratchet releases and then allow them to open freely. If they do not open quickly and fully, the spring is defective and must be replaced. See Paragraph 6, PARTS REPLACEMENT.
4. Inspect the tool frame for wear or damage, paying particular attention to the tool jaws and pivot points. If damage is evident, refer to Paragraph 6, PARTS REPLACEMENT. If tool is acceptable, lubricate and return to service.

#### NOTE



*This tool is recommended for R&D prototyping, networking applications, commercial/industrial maintenance, and field service repair. For other applications, please contact your Tyco Electronics Representative or the Tooling Assistance Center number listed at the bottom of page 1.*

## 5. CRIMP HEIGHT ADJUSTMENT

The tool frame assembly features a ratchet mechanism and adjustment wheel with a range of

settings. The ratchet mechanism ensures that the tool has completed the cycle. The adjustment wheel controls the amount of handle pressure exerted on the tool jaws and crimping dies during the crimping procedure. Although the ratchet is preset prior to shipment, it is important that you verify the crimp height. Also, general use and subsequent wear may cause the tool to go out of adjustment. It is recommended that the crimp height be inspected — and adjusted, if necessary — on a regular basis by quality control personnel.

#### NOTE



*This is a general explanation of the procedure. For specific information, refer to the instruction sheet packaged with the die assembly.*

1. Crimp a contact onto a properly-prepared wire of the correct size.
2. If the crimp height is greater than recommended, remove the ratchet wheel adjustment screw and rotate the adjustment wheel COUNTERCLOCKWISE to a higher setting. Repeat as required.
3. If the crimp height is less than recommended, remove the ratchet wheel adjustment screw and rotate the adjustment wheel CLOCKWISE to a lower setting. Repeat as required.
4. If the crimp cannot be made to conform to the dimensions provided in the appropriate product application specification, the tool and/or dies are defective and must be replaced.

## 6. PARTS REPLACEMENT

PRO-CRIMPER III Hand Crimping Tool Frame Assembly 354940-1 is inspected prior to shipment. It is recommended that it be inspected upon arrival to ensure that it has not become damaged during shipping.

Refer to the parts list in Figure 4 to determine the part number for the item to be replaced and to identify the proper location and orientation of the part in the tool frame.

Additional tools and parts may be ordered from:

CUSTOMER SERVICE (38-35)  
TYCO ELECTRONICS CORPORATION  
P.O. BOX 3608  
HARRISBURG, PA 17105-3608

## 7. REVISION SUMMARY

- Updated document to corporate requirements
- New format

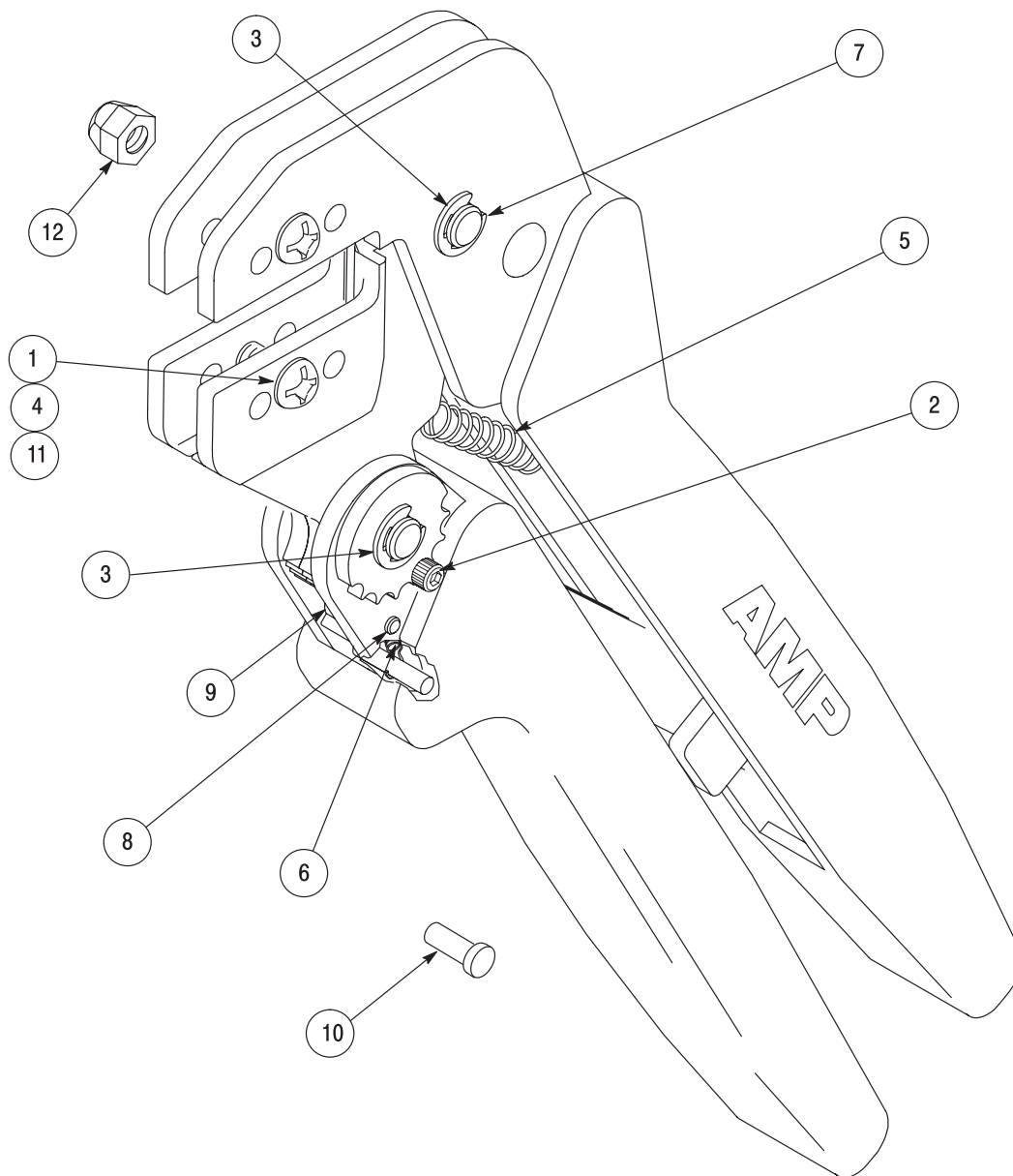

PRO-CRIMPER REPAIR KIT 679221-1●

ITEM	DESCRIPTION	QTY PER KIT	ITEM	DESCRIPTION	QTY PER KIT
1	SCREW, Die Retaining, M4 x 12	2	7	PIN, Pivot	3
2	SCREW, M3 x 4	1	8	PIN, Pawl	3
3	RING, Retaining	7	9	PAWL, Ratchet	1
4	SCREW, Die Retaining, M4 x 14	1	10	PIN, Die Retaining	4
5	SPRING, Extension	1	11	SCREW, Die Retaining, M4 x 25	1
6	SPRING, Extension	1	12	NUT, M4	1

●Parts are NOT available individually

Figure 4