

## Data sheet

### Article Description

#### Line intermediate switch **IP44** Type 9002

16 (4) A, 250 Vac, **2-pole**, on-off switch,  
for devices of protection class I + II,  
**water proof protection**  
LWH: 97 x 52 x 30 mm

screwed strain relief,  
for round cable,  
screw terminals,  
with cable anti-bend protection,  
operating temperature -40° bis 85° C  
suitable for cable cross section up to 2,5 mm<sup>2</sup>

### Article Picture



**Perfect for light strings, electrical lines etc. for outdoor area**

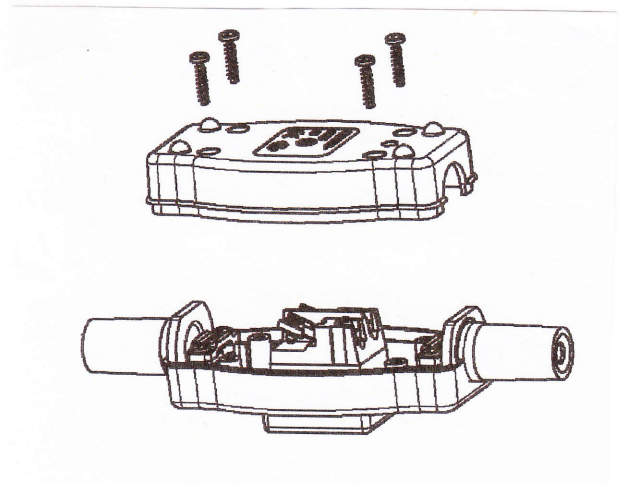
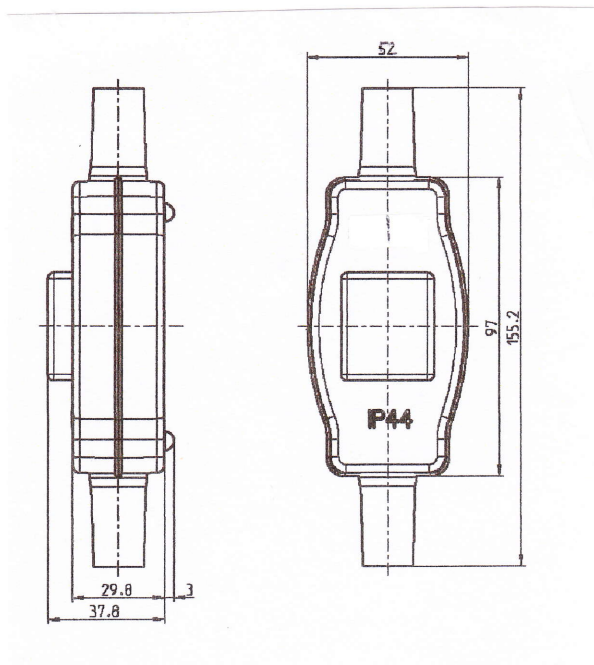

<i>inter BÄR-item no.</i>	<i>colour</i>	<i>version</i>
9002-004.01	black/red	illuminated

**Technical modifications reserved!**  
**Works at 230 V-mains must only be carried out by a specialist!**