

ISS.	AMEND	DATE
1	ISSUED	07/11/12

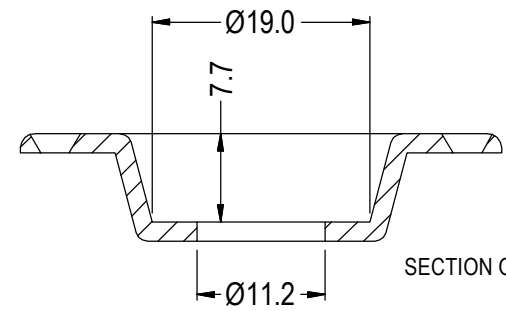

SECTION ON C/L

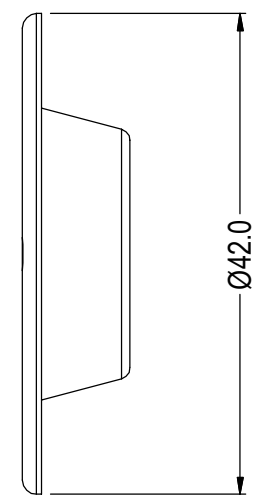
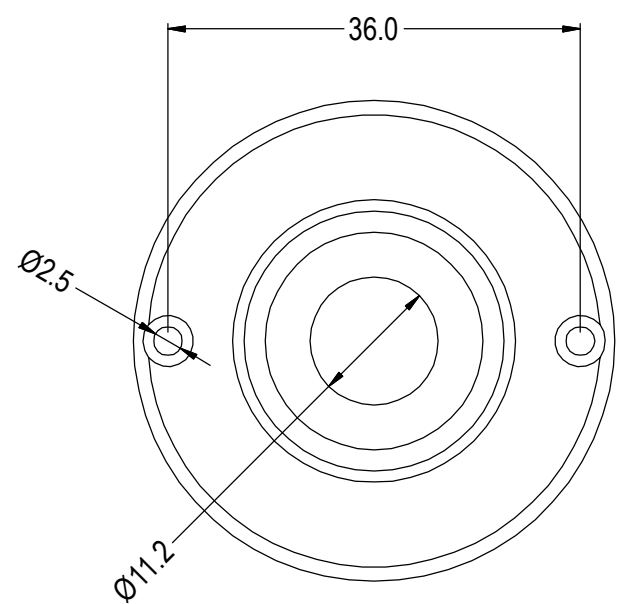
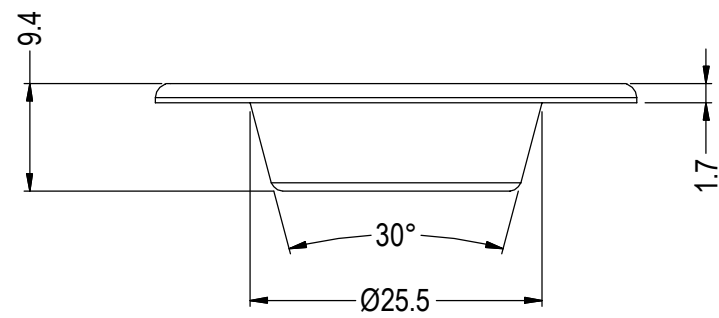

FRONT FACES HAVE TEXTURED FINISH

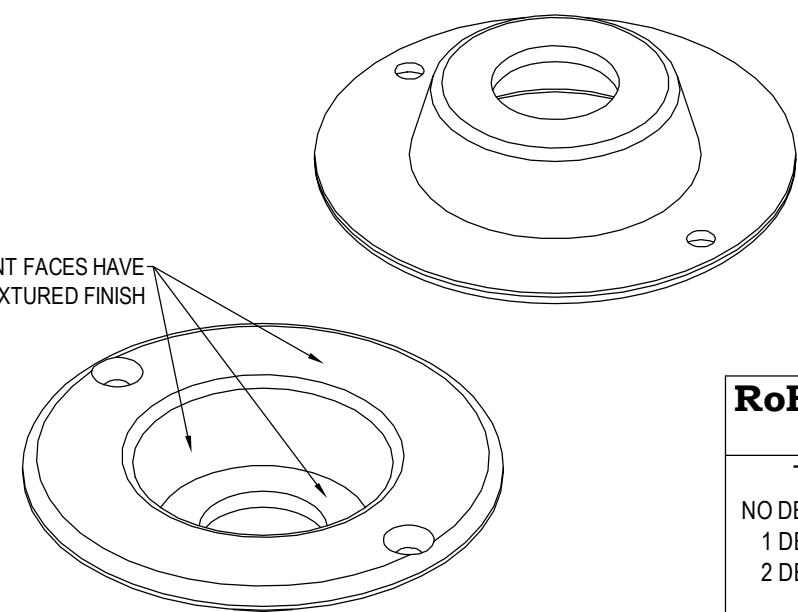

RoHS
COMPLIANT

TOLERANCE
 NO DEC. PLACE ±
 1 DEC. PLACE ±
 2 DEC. PLACE ±
 HOLE Ø ±
 ANGLES ±
 UNLESS OTHERWISE STATED

Cliff Electronic Components Ltd.
 76 Holmethorpe Avenue, Holmethorpe Industrial Estate,
 Redhill, Surrey, RH1 2PF, England, UK
 Tel: 01737-771375 Fax: 01737-766012 Website: www.cliffuk.co.uk

THE CONTENTS OF THIS DOCUMENT MUST NOT BE COPIED OR DISCLOSED TO A 3rd PARTY WITHOUT WRITTEN PERMISSION OF CLIFF UK. © 2012

DIMENSIONS IN MILLIMETERS UNLESS OTHERWISE STATED. WORK TO DIMENSIONS. REMOVE ALL BURRS. IF IN DOUBT ASK.

MATERIAL: POLYPROPYLENE
 FINISH: CLEAN - BLACK
 DRAWN: T.J.O.

3rd ANGLE PROJECTION:

TITLE: RECESS PLATE SRP/1 BLACK
 DRWG. No. CL1396

DO NOT SCALE

FORM: A4DRWGH

APPROVED: D.P.J.