

Technical Data

TRANSISTOR

maximum ratings

Voltage, Collector to Base (VCBO)	60.0	V	NO.	BC140-16
Voltage, Collector to Emitter (VCE)	40.0	V	TYPE	NPN
Voltage, Emitter to Base (VEBO)	7.0	V		
Collector Current (IC)	1.0	A		
Base Current (IB)	0.1	A	CASE	TO-39
Max. Power Dissipation (PT) at TC = 25 °C	4.0	W		
Max. Thermal Resistance (Rth J-C)	44.0	°C/W		
Max. Junction Temperature (TJ)	200.0	°C		

PERFORMANCE CHARACTERISTICS at $T_c = 25^\circ\text{C}$, unless otherwise noted

NO.	SYMBOL	CONDITIONS	MIN.	MAX.	UNITS
1.	BVCEO	IC = 10.0 mA (1)	40.0	-	V
2.	BVCBO	IC = 100.0 μA	60.0	-	V
3.	BVEBO	IE = 100.0 μA	7.0	-	V
4.	ICBO	VCB = 50.0 V	-	200.0	nA
5.	ICBO	VCB = 50.0 V, TA = 150.0° C	-	200.0	μA
6.	hFE	IC = 100.0 μA , VCE = 1.0 V (2)	90.0	-	-
7.	hFE	IC = 100.0 mA, VCE = 1.0 V (1)	160.0	250.0	-
8.	hFE	IC = 1.0 A, VCE = 1.0 V (2)	30.0	-	-
9.	VCE(SAT)	IC = 100.0 mA, IB = 10.0 mA (2)	-	0.1	V
10.	VCE(SAT)	IC = 500.0 mA, IB = 50.0 mA (2)	-	0.35	V
11.	VCE(SAT)	IC = 1.0 A, IB = 0.1 A (1)	-	1.0	V
12.	VBE(ON)	IC = 1.0 A, VCE = 1.0 V (1)	-	1.8	V
13.	fT	IC = 50.0 mA, VCE = 10.0 V	50.0	-	MHz
14.	Cobo	VCB = 20.0 V, f = 1.0 MHz (3)	-	12.0	pF
15.	tON	IC = 100.0 mA, IB = 5.0 mA	-	250.0	ns
16.	tOFF	IC = 100.0 mA, IB = 5.0 mA	-	850.0	ns
17.					
18.					
19.					
20.					

Notes (1)pulse-tested $t_p \leq 300 \mu\text{s}$, duty cycle $\leq 2\%$
 (2)typ. value / pulse-tested $t_p \leq 300 \mu\text{s}$, duty cycle $\leq 2\%$
 (3)typical value

DIMENSIONS
in mm

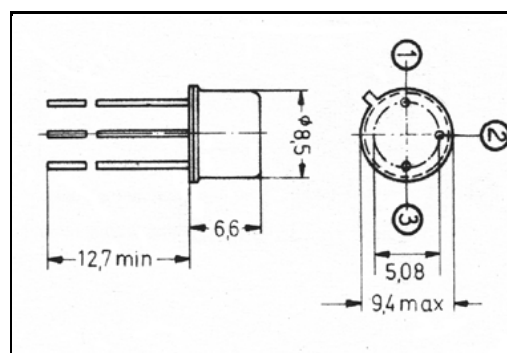

Marking BC140-16

Customer GENERAL PURPOSE