

Silicon NPN Power Transistors

2SD2399

DESCRIPTION

- With TO-220F package
- Complement to type 2SB1568
- High DC current gain.
- DARLINGTON

APPLICATIONS

- For low frequency power amplifier applications

PINNING

PIN	DESCRIPTION
1	Base
2	Collector
3	Emitter

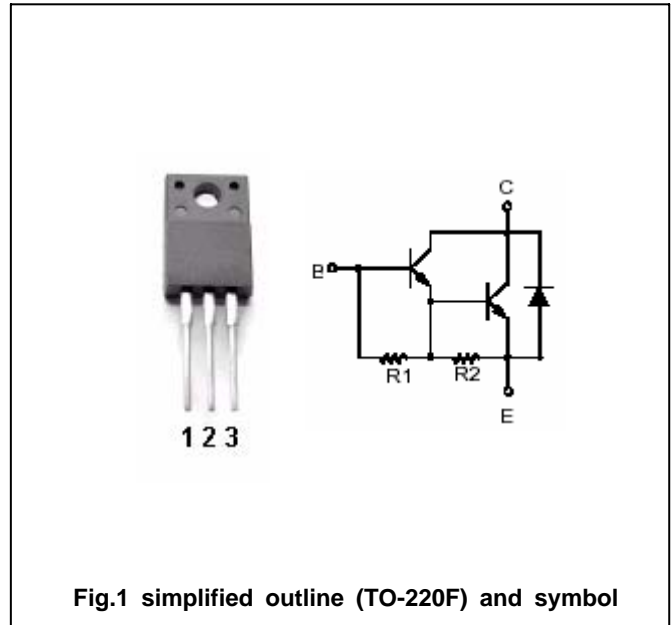

Absolute maximum ratings (Ta=25°C)

SYMBOL	PARAMETER	CONDITIONS	VALUE	UNIT
V <sub>CB0</sub>	Collector-base voltage	Open emitter	80	V
V <sub>CE0</sub>	Collector-emitter voltage	Open base	80	V
V <sub>EBO</sub>	Emitter-base voltage	Open collector	7	V
I <sub>C</sub>	Collector current		4	A
I <sub>CM</sub>	Collector current-peak	Single pulse	6	A
P <sub>C</sub>	Collector dissipation	T <sub>C</sub> =25°C	30	W
		T <sub>a</sub> =25°C	2	
T <sub>j</sub>	Junction temperature		150	°C
T <sub>stg</sub>	Storage temperature		-55~150	°C

## Silicon NPN Power Transistors

## 2SD2399

## CHARACTERISTICS

T<sub>j</sub>=25°C unless otherwise specified

SYMBOL	PARAMETER	CONDITIONS	MIN	TYP.	MAX	UNIT
V <sub>(BR)CBO</sub>	Collector-base breakdown voltage	I <sub>C</sub> =50 μ A; I <sub>E</sub> =0	80			V
V <sub>(BR)CEO</sub>	Collector-emitter breakdown voltage	I <sub>C</sub> =1mA; I <sub>B</sub> =0	80			V
V <sub>CEsat</sub>	Collector-emitter saturation voltage	I <sub>C</sub> =2A ; I <sub>B</sub> =4mA			1.5	V
I <sub>CBO</sub>	Collector cut-off current	V <sub>CB</sub> =80V; I <sub>E</sub> =0			0.1	mA
I <sub>EBO</sub>	Emitter cut-off current	V <sub>EB</sub> =5V; I <sub>C</sub> =0			3.0	mA
h <sub>FE</sub>	DC current gain	I <sub>C</sub> =2A ; V <sub>CE</sub> =3V	1000		10000	
C <sub>OB</sub>	Output capacitance	I <sub>E</sub> =0 ; V <sub>CB</sub> =10V; f=1MHz		35		pF
f <sub>T</sub>	Transition frequency	I <sub>E</sub> =-0.2A ; V <sub>CE</sub> =5V; f=10MHz		40		MHz

Silicon NPN Power Transistors

2SD2399

PACKAGE OUTLINE

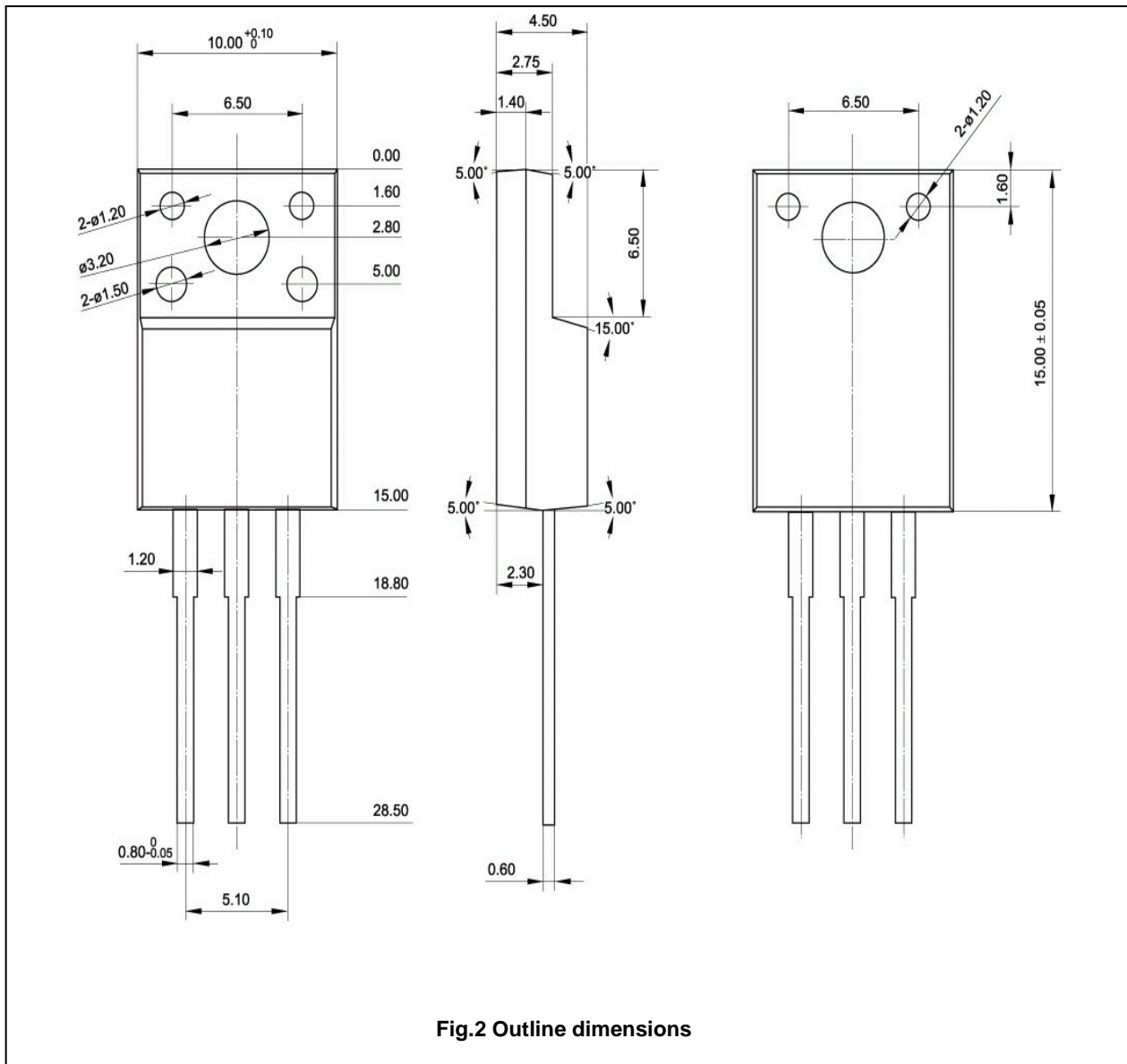

Fig.2 Outline dimensions