

V/F Converter

IR9331/IR9331N

T-73-13-03

IR9331/IR9331N V/F Converter

Description

The IR9331/IR9331N is a voltage-to-frequency converters ideally suited for use in simple low-cost circuits for A/D conversion, precision F/V conversion, longterm intergration, linear frequency modulation or demodulation, and many other functions.

Features

1. Guaranteed linearity 0.01%FS (MAX.)
2. Excellent temperature stability
±30ppm/°C (TYP.)
3. Wide dynamic range 100dB at 10kHz FS* (MIN.)
4. Wide range of FS frequency 1~100kHz
5. Wide range of supply voltage 4~40V
6. 8-pin dual-in-line package (IR9331)
8-pin small-outline package (IR9331N)

* FS: Full Scale

Pin connections

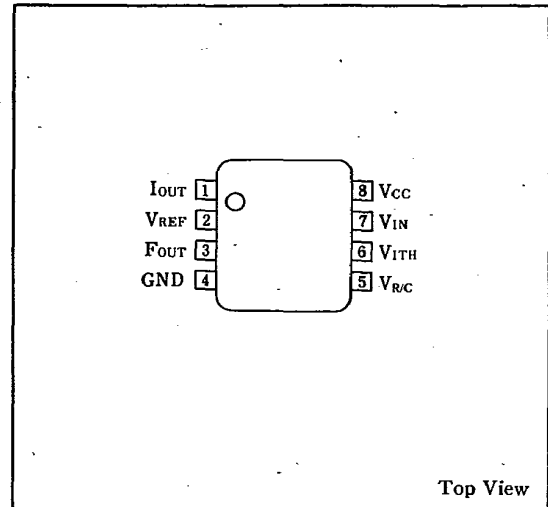

Block Diagram

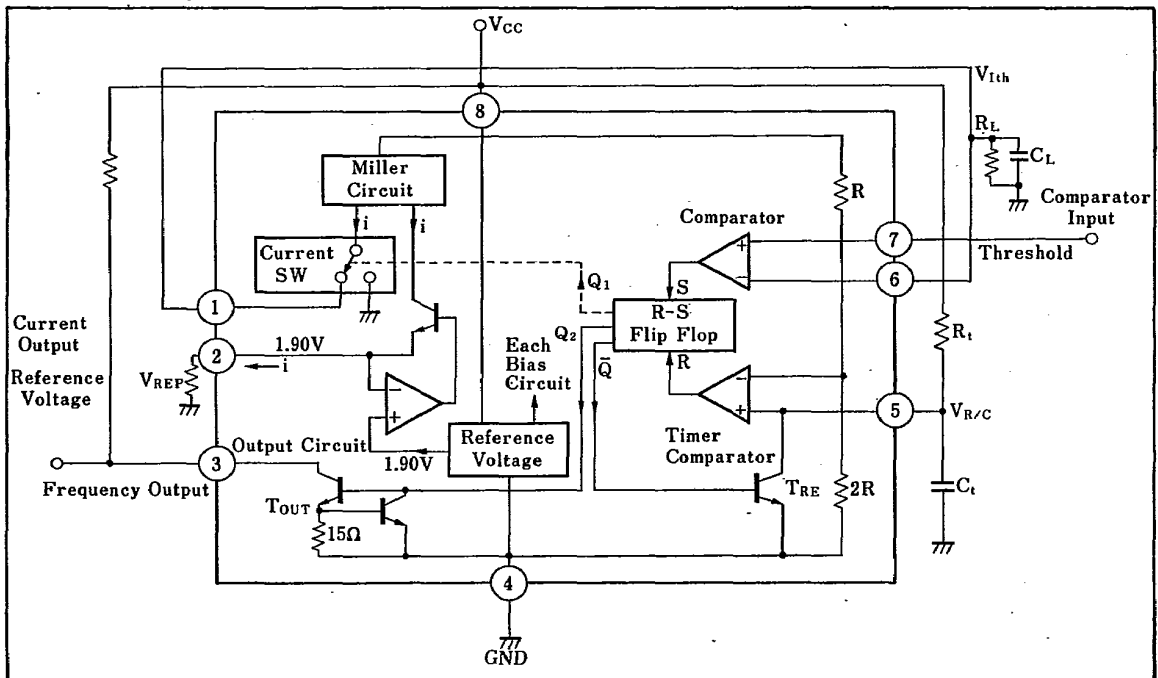

V/F Converter

T-73-13-03

IR9331/IR9331N

Absolute Maximum Ratings

(Ta=25°C)

Parameter	Symbol	Condition	Rating	Unit	
Supply voltage	V _{CC}		40	V	
Input voltage	V _{R/C}		-0.2~V _{CC}	V	
	V _{Ith}				
	V _{IN}				
Output short-circuit time	t _{SG}	to GND	Infinity	s	
	t _{SV}	to V _{CC} , short-circuit 30mA(TYP.)	Infinity		
Power dissipation	P _D	Ta≤25°C	IR9331	500	mW
			IR9331N	450	
P _D derating ratio	ΔP _D /°C	Ta>25°C	IR9331N	4.5	mW/°C
Operating temperature	T _{opr}		-10~+70	°C	
Storage temperature	T _{stg}		-55~+150	°C	

Electrical Characteristics

(V_{CC}=15V, Ta=25°C, Test circuit 1)

Parameter	Symbol	Condition	MIN.	TYP.	MAX.	Unit
VFC non linearity error *2	NL _b	4.5V≤V _{CC} ≤20V		±0.003	±0.01	%FS
	NL _b '	T _{opr} (-10~70°C)		±0.006	±0.02	
	NL _a	V _{CC} =15V, f _{OUT} Test circuit 2*1		±0.10	±0.30	
Scale factor (gain)	SF	V _{IN} =-10V, R _S =14kΩ	0.90	1.00	1.10	kHz/V
Gain temperature coefficient	α SF	4.5V≤V _{CC} ≤20V T _{opr} (-10~+70°C)		±30		ppm/°C
Gain-power supply stability	SVR	4.5V≤V _{CC} ≤10V		0.01	0.15	%V
	SVR'	10V≤V _{CC} ≤40V		0.006	0.06	
Full scale frequency	F _{FS}	V _{IN} =-10V	10.0			kHz
Over range frequency	F _{over}	V _{IN} =-11V	10			%

Input comparator (terminal 6 and 7)

Parameter	Symbol	Condition	MIN.	TYP.	MAX.	Unit
Offset voltage	V _{IO1}			±3	±10	mV
	V _{IO2}	T _{opr} (-10~+70°C)		±4	±14	
Bias current	I _B			-80	-300	nA
Offset current	I _{IO}			±8	±100	nA
In-phase input range	V _{ICM}	T _{opr} (-10~+70°C)	-0.2		V _{CC} -2.0	V

Timer (terminal 5)

Parameter	Symbol	Condition	MIN.	TYP.	MAX.	Unit
Timer threshold voltage	V _{Ith}		0.63	0.667	0.70	(×V _{CC})V
Input bias current	I _{I5}	V _{CC} =15V, 0V≤V ₅ ≤9.9V		±10		nA
	I _{I5} '	V _{CC} =15V, V ₅ =10V		200	1,000	
Saturation voltage (reset)	V _{SAT5}	I=5mA		0.22	0.5	V

Power supply source (terminal 1)

Parameter	Symbol	Condition	MIN.	TYP.	MAX.	Unit
Output current	I _{OUT}	R _S =14kΩ, V _I =0V	116	136	156	μA
I _{OUT} -Voltage fluctuation	I _{OV}	0V≤V _I ≤10V		0.7	1.5	μA
OFF-state leakage current	I _{OFF}			0.02	10.0	nA
	I _{OFF} '	Ta=70°C		2.0	50.0	
Operating current range	I _{opr}			10~500		μA

Reference voltage (terminal 2)

Parameter	Symbol	Condition	MIN.	TYP.	MAX.	Unit
Reference voltage	V _{REF}		1.70	1.89	2.08	V _{DC}
Temperature coefficient	α V _{REF}			±60		ppm/°C
Time drift	α V _{REF}	1,000 hours		±0.1		%

Logic output (Terminal 3)

Parameter	Symbol	Condition	MIN.	TYP.	MAX.	Unit
Saturation voltage	V _{SAT3}	I=5mA		0.15	0.50	V
	V _{SAT3} '	I=3mA		0.10	0.40	
OFF-state leakage current	I _{OFF3}			0.05	1.0	μA

SHARP

Parameter	Symbol	Condition	MIN.	TYP.	MAX.	Unit
Supply current (terminal 8)						
Supply current	I_{CC}	$V_{CC}=5V$	1.5	3.0	6.0	mA
	I_{CC}'	$V_{CC}=40V$	2.0	4.0	8.0	

- *1 $f_{OUT}=10Hz\sim 11kHz$, this test alone is to be performed on test circuit 2.
- *2 Non-linearity error is defined as the deviation from $V_{IN} \times (10kHz/-10V_{DC})$ at $f_{OUT}=1Hz\sim 11kHz$.
(Full scale adjustment at 10kHz, zero adjustment at 10kHz)

Test Circuit

- (1) Test circuit (Precision V/F conversion circuit) (2) Test circuit 2 (Simple V/F conversion circuit)

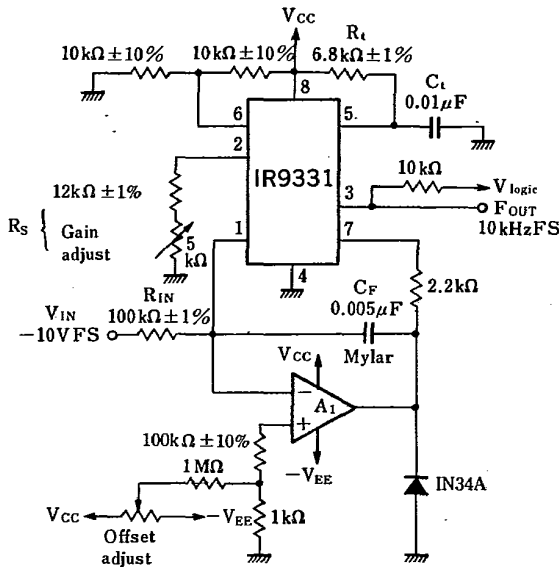

A₁ : Use an operational amplifier that satisfies the following conditions:
 Input offset voltage below 1mV
 Input offset current below 2nA

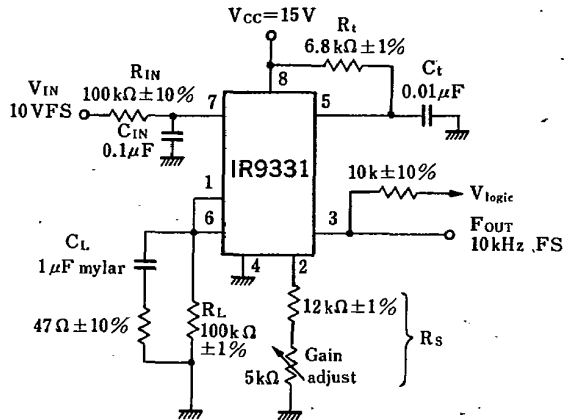

Electrical Characteristics Curves (Unless otherwise specified, $V_{CC}=15V$, $T_a=25^{\circ}C$)

Non-linearity error—Output frequency Characteristics

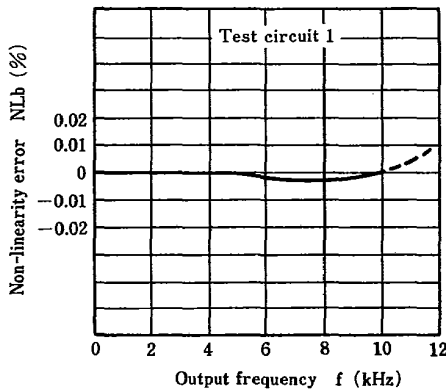

Non-linearity error—Output frequency Characteristics

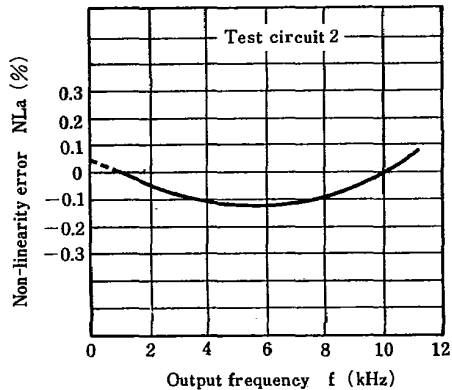

Reference voltage—Ambient temperature Characteristics

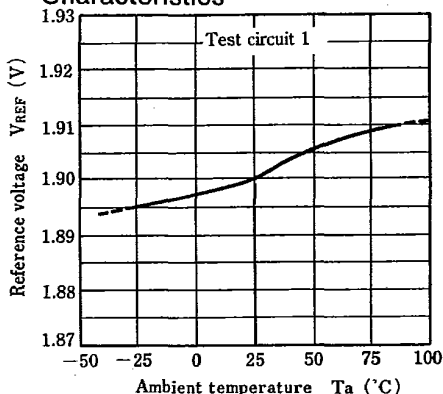

Supply current—Supply voltage Characteristics

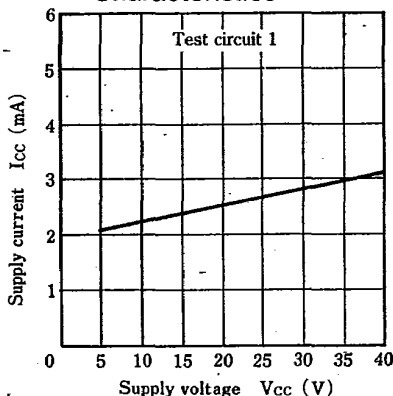

Description of Operation

The IR9331 is organized mainly as an input comparator, R-S flip-flop, timer comparator, current supply, current switch 1.9V reference voltage supply and output circuit. To briefly explain the circuit operation, the feed-back of this circuit is organized in supply, current switch 1.9V reference voltage supply and output circuit. To briefly explain the circuit V_{IN} is higher, C_L will be discharged through R_L in a relatively short time to settle for a lower frequency. That is to say that it operates as a highly accurate loose coupling oscillator that produces frequencies linearly in proportion to the input voltage.

Following is a detailed description.

Suppose that the voltage V_{Ith} (terminal 6) becomes as satisfies $V_{Ith} < V_{IN}$. The input comparator compares V_{Ith} and V_{IN} to set the R-S flip-flop. The Q_1 output of F.F closes the current switch and starts charging C_L with the current i . At the same time the Q_2 output turns on the frequency output transistor (T_{OUT}) while the \bar{Q} turns off the reset transistor (T_{RE}). From this moment on C_T will continue to get charged logarithmically toward V_{CC} . When the voltage of C_T has come up to $2/3 V_{CC}$, the timer comparator applies reset output to F.F. The time taken so far is about $1.1R_t C_t$ ($1.1 = \ln 0.333...$)

Even if the timer comparator generate reset output, the F.F will remain set so long as $V_{Ith} \leq V_{IN}$, in which it will continue being charged well beyond $2/3 V_{CC}$ until it gets to the state where $V_{Ith} > V_{IN}$. This condition arises on power-up or when an excessively higher signal gets in to have the output frequency 0. It will, however, go back to normal if V_{IN} restores within the operating range.

F.F will not be reset until the reset output is produced and a condition is reached as satisfies V_{Ith}

V_{IN} . The current switch opens to have C_L start discharging (until it reaches a point where $V_{Ith} > V_{IN}$). Simultaneously with the resetting of F.F, T_{RE} turns on to have C_T discharge itself. Also T_{OUT} turns off. The number of the repetition of this cycle above over and over again in a second is the frequency as defined.

How to work out the output frequency

$$f_{OUT} = \frac{1}{T_1 + T_2}, \quad i = V_{REF}/R_S$$

$$T_1 = -R_t C_t \ln(1/3) \approx 1.1 R_t C_t \quad \text{Charging time for } C_L$$

$$T_2 = \frac{(i - V_{IN}/R_L) R_L}{V_{IN} V_{IN}} T_1 \quad \text{Charging time for } C_L$$

$$f_{OUT} = \frac{V_{IN} V_{IN}}{i R_L T_1} = \frac{V_{IN}}{V_{REF}} \cdot \frac{R_S}{R_L} \cdot \frac{1}{1.1 R_t C_t}$$



Timing Chart

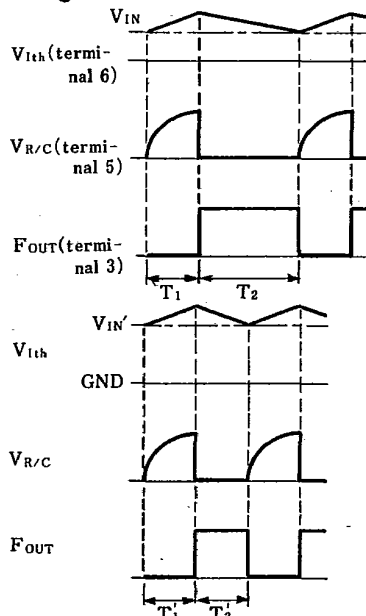

■ Equivalent Circuit

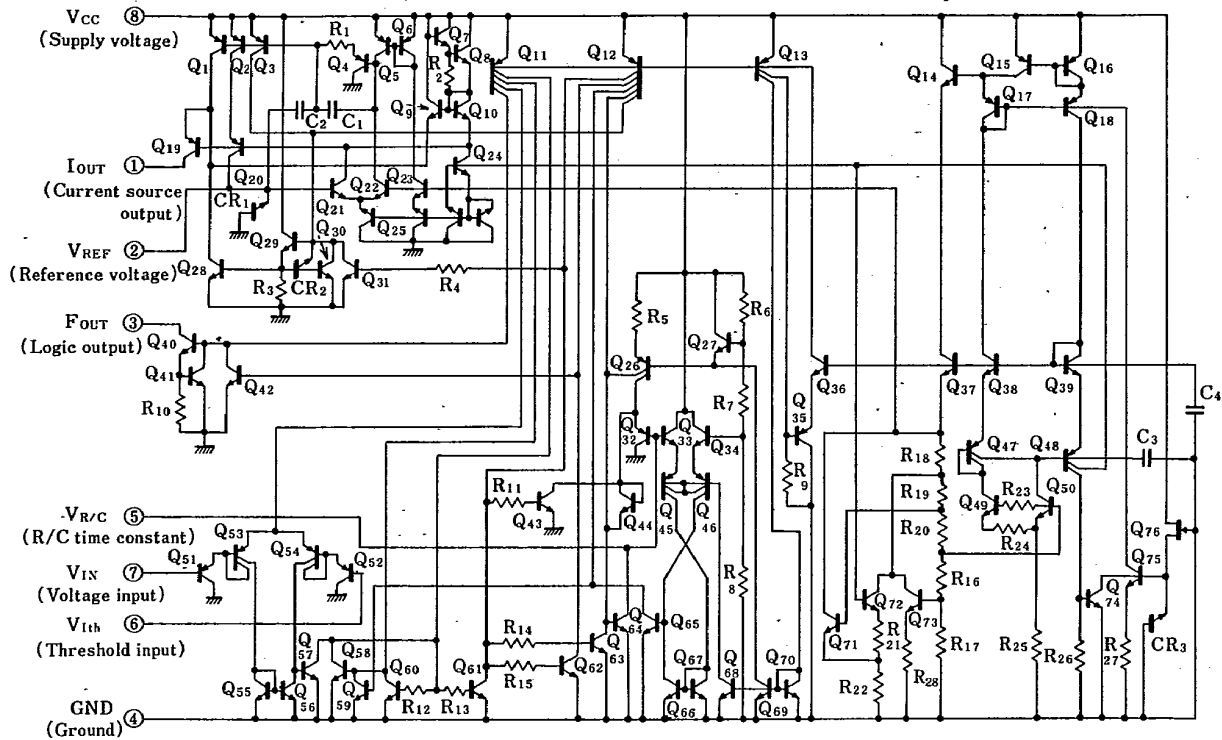

Application Circuit Example

(1) Simple F/V conversion

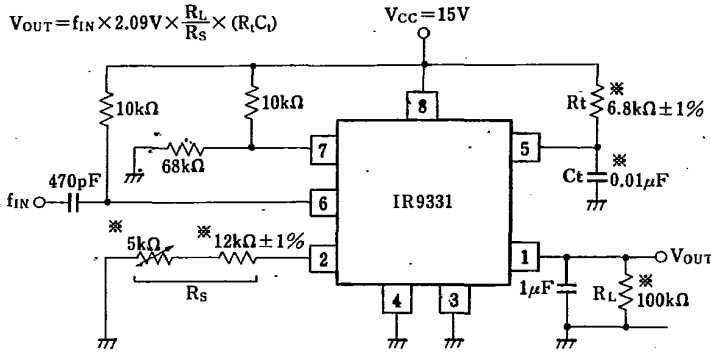

[Full-scale : 10kHz
 [Non-linearity : ±0.06%,

(2) High grade F/V conversion

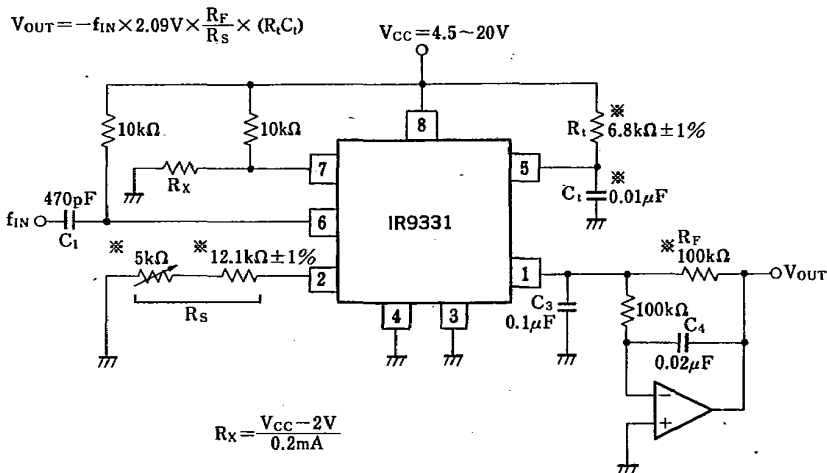

[Full-scale : 10kHz
 [Non-linearity : ±0.01%

※ Use resistors with reduced coefficient of temperature.

(3) High grade F/V conversion

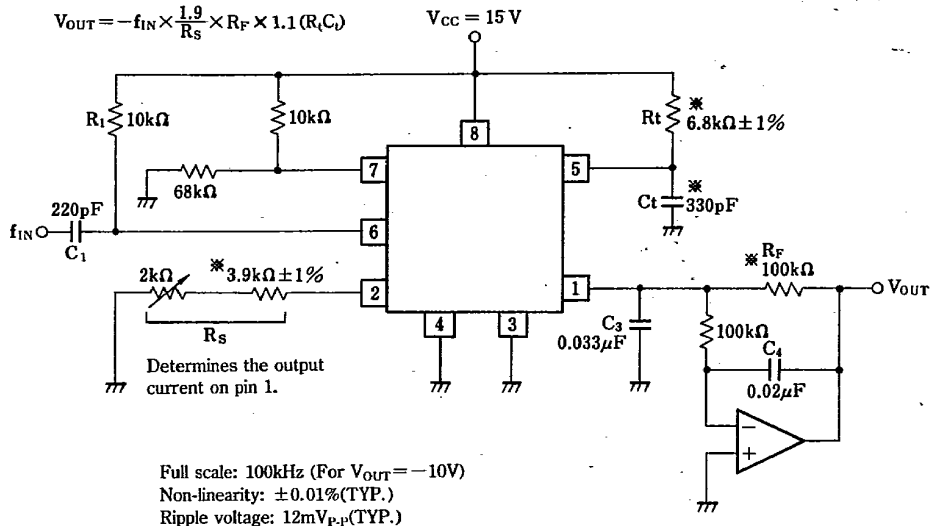

※ Use resistors with reduced coefficient of temperature.

(4) High grade F/V conversion (100kHz full-scale)

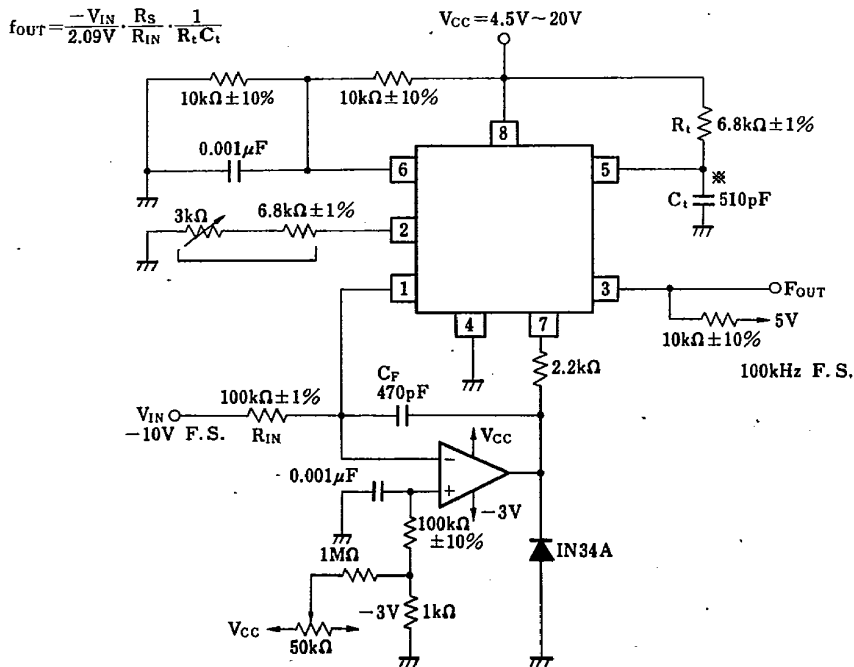

※ Use resistors with reduced coefficient of temperature.