

Extrusion

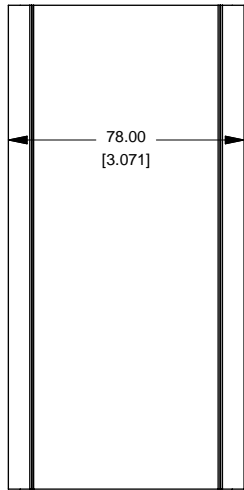

Slot Details

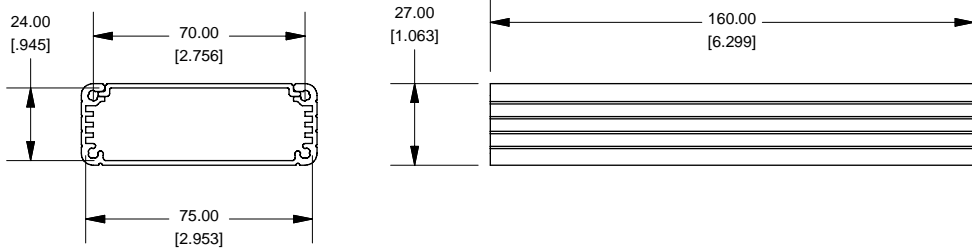
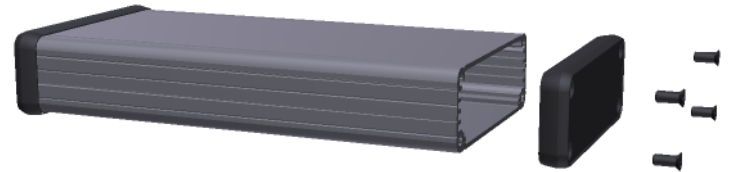
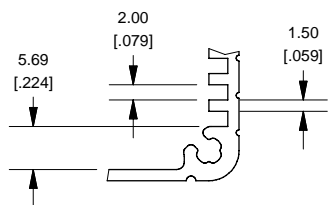

Closed Bezel

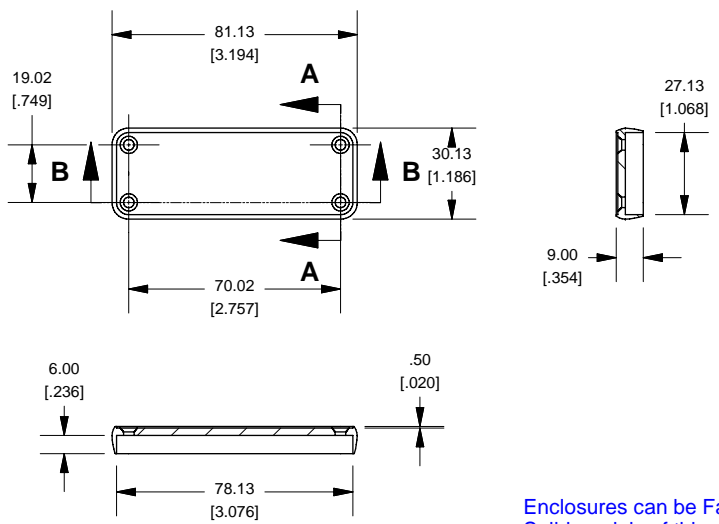

NOTE
 Purchased assembly includes box, plastic bezels, #6 Taptight screws and self adhesive rubber feet.
 Box made from Extruded Aluminum 6063.
 Bezels made with ABS

1455J1602	
PART NUMBERS	
Clear Anodized	1455J1602
Black Anodized	1455J1602BK
ACCESSORIES	
See website for accessories.	

**HAMMOND
MANUFACTURING™**

1455J1602
www.hammondmfg.com

Enclosures can be Factory Modified (Milling, Drilling, Printing etc.)
 Solid models of this enclosure available in STEP or IGES.
 Contact Factory mjm@hammondmfg.com