

### Top View of Assembly

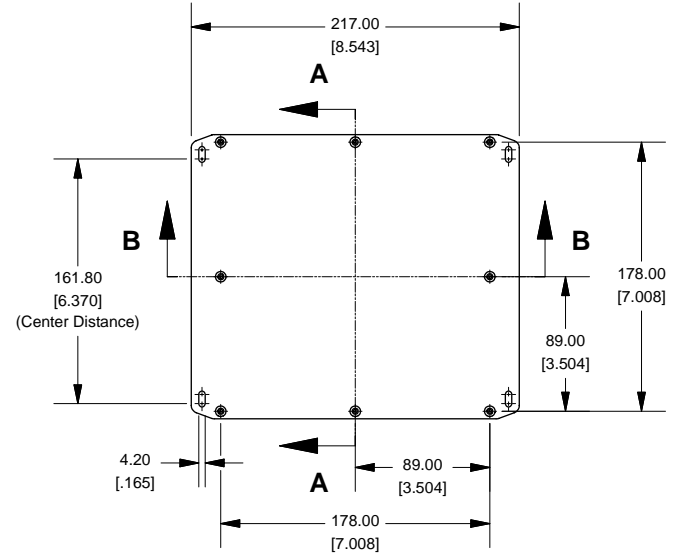

### SECTION A-A End View of Assembly

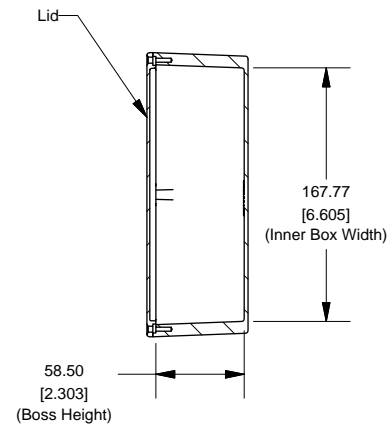

## Series 1590FF (Flanged Lid)

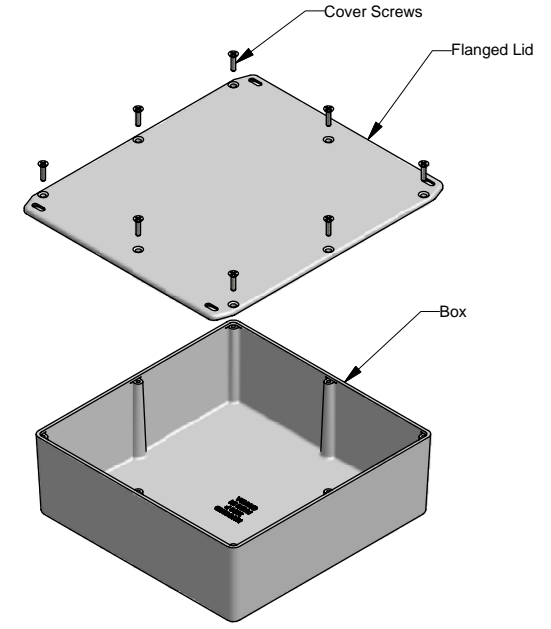

### SECTION B-B Side View of Assembly

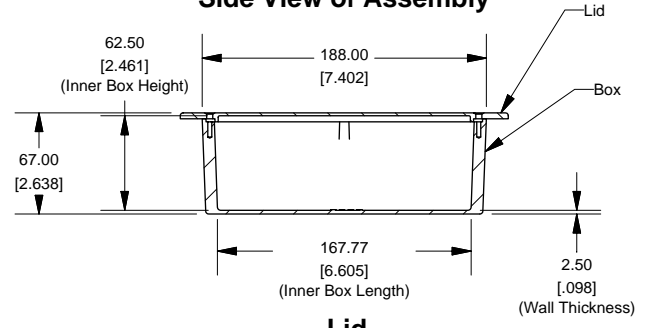

### Top View Looking Inside Box

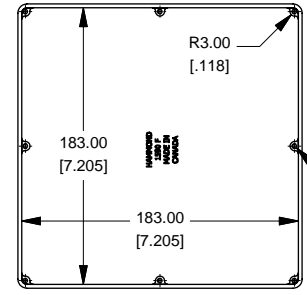

6-32 UNC - 2B  $\nabla$  10.00 (Threaded Holes)

**NOTE**  
 Purchased assembly includes box, lid and 4 cover screws.  
 Box and lid are made from Diecast Aluminum Alloy (alloy type 360.1).

PART NUMBERS	
<b>1590FFL Enclosure</b>	
Unfinished	1590FFL
Black Textured Powder Paint	1590FFLBK
<b>1590WFFL Liquid Resistant Enclosure (Silicon Factory Installed Gasket)</b>	
Unfinished	1590WFFL
Black Textured Powder Paint	1590WFFLBK
ACCESSORIES	
Unfinished	
Cover Screws (Pkg 100)	
[6-32 x 1/2" Nickel Plated Screws]	1590MS100
Black Textured Powder Paint	
Cover Screws (Pkg 50)	
[6-32 x 1/2" Stainless Steel Black Screws]	1590MS50BK

### Lid

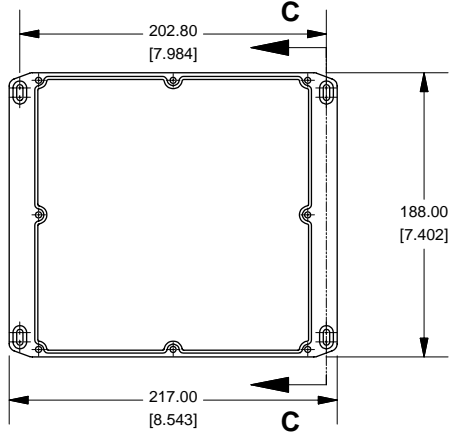

### SECTION C-C Side View of Slot

