

### Top View of Assembly

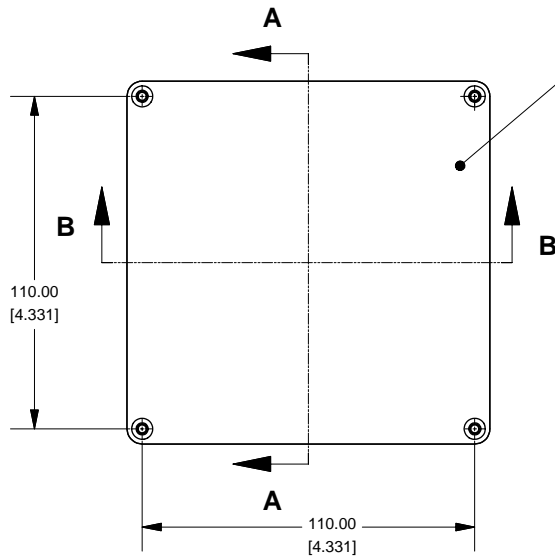

### SECTION A-A End View of Assembly

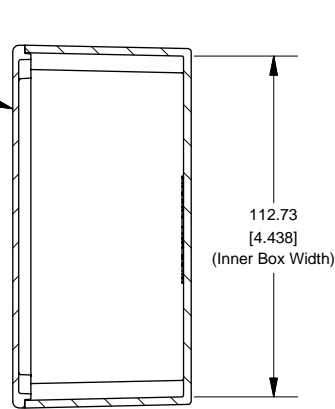

## Series 1590U

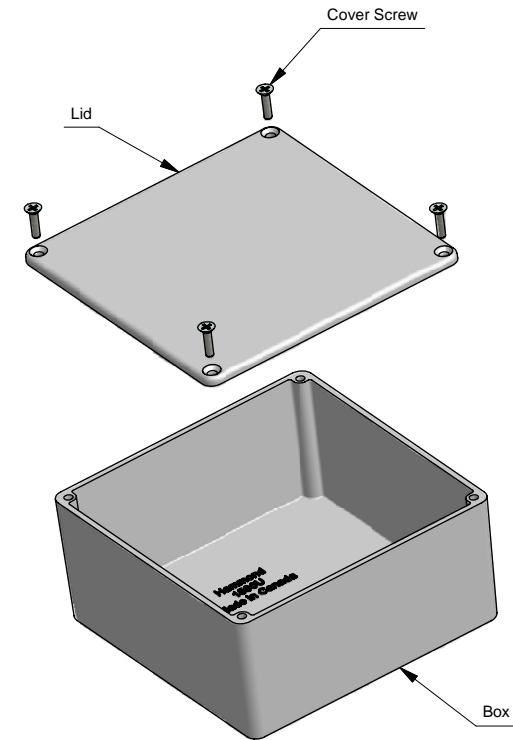

### SECTION B-B Side View of Assembly

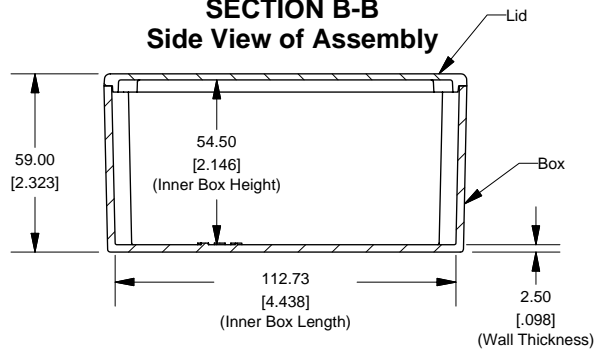

### Top View Looking Inside Box

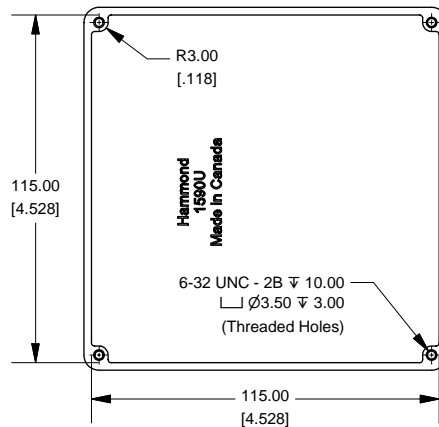

### Lid

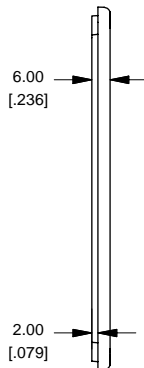
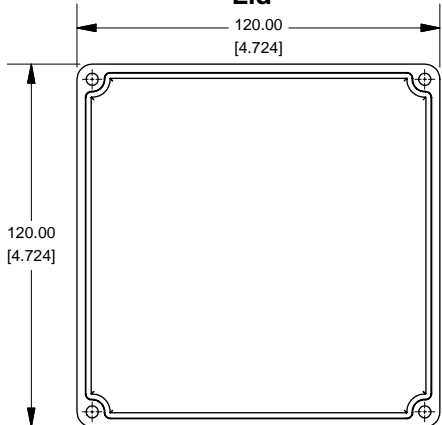

**NOTE**  
Purchased assembly includes box, lid and 4 cover screws.  
Box and lid are made from Diecast Aluminum Alloy (alloy type 360.1).

PART NUMBERS	
<b>1590U Enclosure</b>	
Unfinished	1590U
Black Textured Powder Paint	1590UBK
<b>1590U Liquid Resistant Enclosure (Silicon Factory Installed Gasket)</b>	
Unfinished	1590WU
Black Textured Powder Paint	1590WUBK
<b>ACCESSORIES</b>	
Unfinished	
Cover Screws (Pkg 100)	
[6-32 x 1/2" Nickel Plated Screws]	1590MS100
Black Textured Powder Paint	
Cover Screws (Pkg 50)	
[6-32 x 1/2" Stainless Steel Black Screws]	1590MS50BK



www.hammondmfg.com