

# 1591G

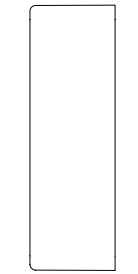

SIDE VIEW OF BOX

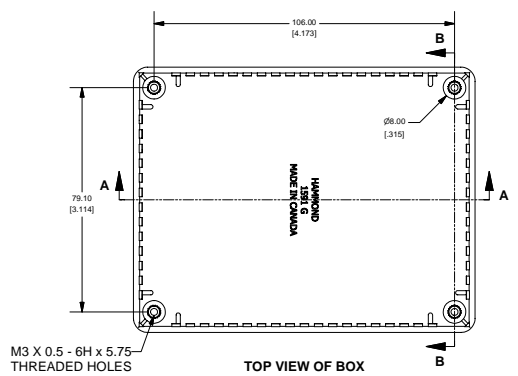

TOP VIEW OF BOX

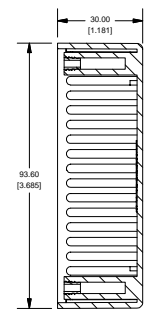

SECTION B-B  
SCALE 3/4

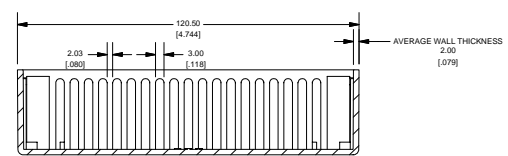
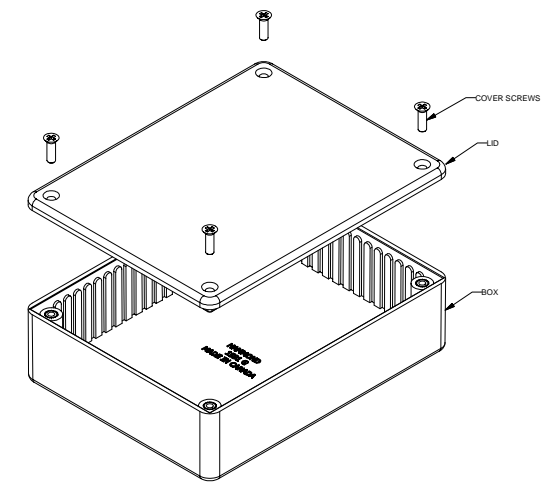

SECTION A-A  
SCALE 3/4

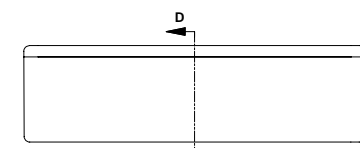

SIDE VIEW OF ASSEMBLY

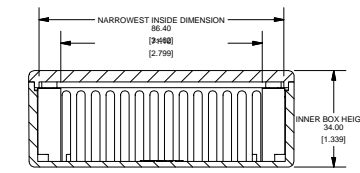

SECTION D-D  
SCALE 3/4

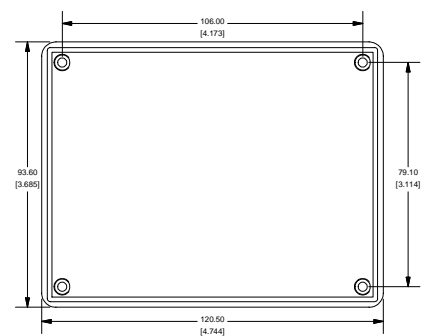
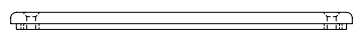

END VIEW OF ASSEMBLY

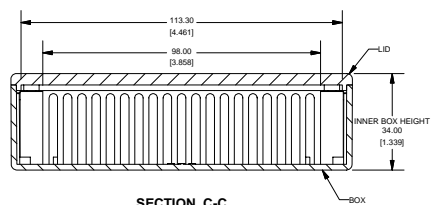
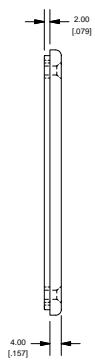

SECTION C-C  
SCALE 3/4

PART NUMBERS			
1591G Enclosures			
Material	Colour	Part Number	
ABS	Beige	1591GBG	
	Black	1591GBK	
	Blue	1591GBU	
	Grey	1591GGY	
	Black Shielded	1591RGBK	
GP ABS	Black	1591GSBK	
Translucent Polycarbonate	Ice Blue	1591GTBU	
	IR Red	1591GTRD	
	Crystal Clear	1591GTCL	
Accessories			
Description	Part Number		
Used with ABS and Translucent Polycarbonate Enclosures	PC Board Card Adapters	See Accessories Section	
	Flange Kits	See Accessories Section	
	Replacement Screws, nickel plated M3 - 0.5 x 10mm, Pack of 100.	1591MS100	
	Belt/Pocket Clip, w/ nylon screws (insulated to avoid interference) and mounting template	1599CLIP - Black 1599CLIPGY - Grey	
	Clear Lids - clear, flame retardant polycarbonate - Lid ONLY	1591GC	
Used with GP ABS Enclosure	PC Board Card Adapters	See Accessories Section	
	Flange Kits	See Accessories Section	
	Belt/Pocket Clip, w/ nylon screws (insulated to avoid interference) and mounting template	1599CLIP - Black 1599CLIPGY - Grey	
	Replacement Screws, self tapping, black oxide, #4 x 0.5, Pack of 100	1591TS100BK	
	Clear Lids - clear, flame retardant polycarbonate - Lid ONLY	1591GC	
Required Torque on Fasteners (no lubrication)			
	M3 - 0.5 x 10mm Screws	30-40 cN*m	
	#4 x 0.5 Screws	30-40 cN*m	

