



Technical Data Sheet

3.0 mm Round LED (T-1 3/4)

204-15UTC/C470

Features

- Popular T-1 colorless 3mm package.
 - High luminous power.
 - Typical chromaticity coordinates $x=0.29, y=0.28$ according to CIE1931.
 - Bulk, available taped on reel.
 - Pb free .
- The product itself will remain within RoHS compliant version.

Descriptions

- The series is designed for application required high luminous intensity.
- The phosphor filled in the reflector converts the blue emission of InGaN chip to ideal white.

Applications

- Outdoor Displays
- Optical Indicators
- Backlighting
- Marker Lights

Device Selection Guide

PART NO.	Chip		Lens Color
	Material	Emitted Color	
204-15UTC/C470	InGaN/Sapphire	White	Water Clear

Package Dimensions

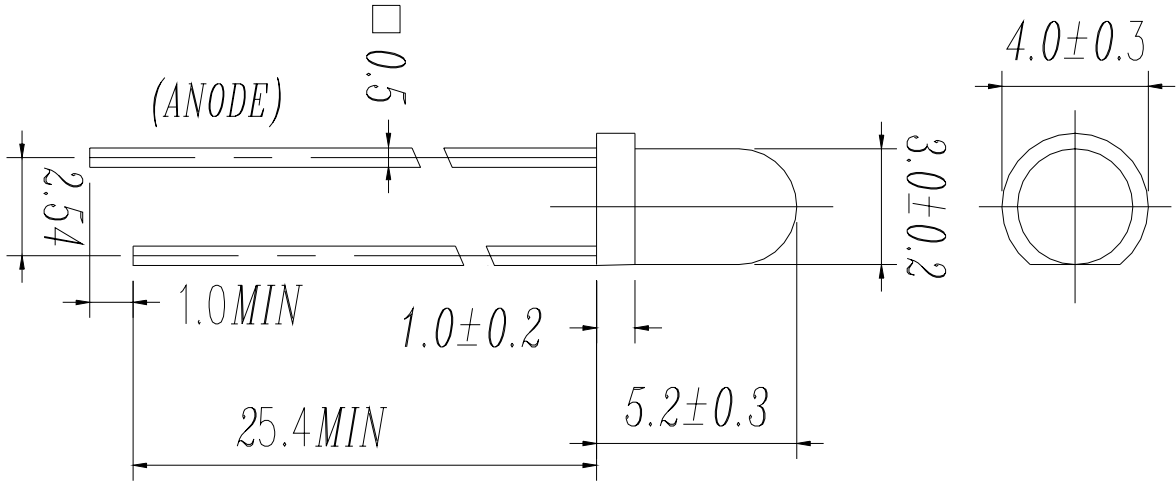

Notes:

- 1.All dimensions are in millimeters, and tolerance is 0.25mm except being specified.
- 2.Lead spacing is measured where the lead emerges from the package.
- 3.Protruded resin under flange is 1.5mm Max. LED.

Absolute Maximum Ratings (Ta=25°C)

Parameter	Symbol	Rating	Unit
Continuous Forward Current	I _F	25	mA
Reverse Voltage	V _R	5	V
Operating Temperature	T _{opr}	-30 ~ +85	°C
Storage Temperature	T _{stg}	-40 ~ +100	°C
Soldering Temperature (T=5 sec)	T _{sol}	260 ± 5	°C
Power Dissipation	P _d	120	mW
Electrostatic Discharge	ESD	1000	V

Electro-Optical Characteristics (Ta=25°C)

Parameter	Symbol	Condition	Min.	Typ.	Max.	Units
Forward Voltage	V _F	I _F =20mA	--	3.2	4.0	V
Reverse Current	I _R	V _R =5V	--	--	50	uA
Luminous Intensity	I _V	I _F =20mA	1000	2250	7595	mcd
Viewing Angle	2θ 1/2	I _F =20mA	--	20	--	deg
Chromaticity Coordinates	x	I _F =20mA	--	0.29	--	
	y	-----	--	0.28	--	

Luminous Intensity Combination (mcd at 20mA)

I _V Ranks	K	L	M	N	P
Min.	1000	1500	2250	3375	5063
Max.	1500	2250	3375	5063	7595

Measurement Uncertainty of Luminous Intensity: ±15%

Forward Voltage Combination (V at 20mA)

V _F Rank	0	1	2	3	4	5
Min.	2.8	3.0	3.2	3.4	3.6	3.8
Max.	3.0	3.2	3.4	3.6	3.8	4.0

*Measurement Uncertainty of Forward Voltage : ±0.1V

CIE Chromaticity Diagram

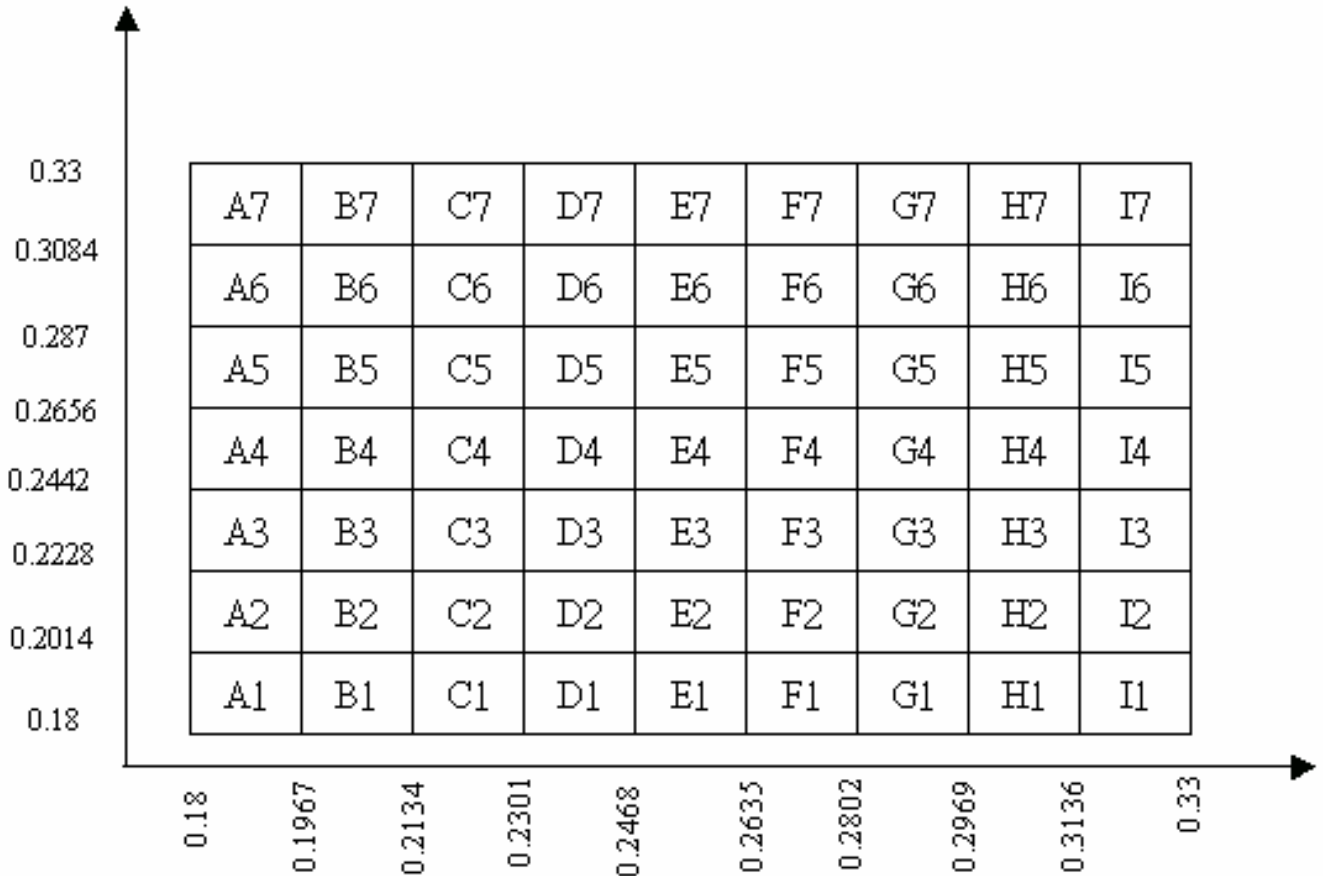

Measurement uncertainty of the color coordinates : ± 0.01

Note:

The setting and inspection for this device please flow the area of x y chromaticity diagram.

Take the upper and lower point for x-axis and y-axis and then put it same parts, x-axis divide into 9 section, y-axis divide into 7 section, total is 63 bins.

Typical Electro-Optical Characteristics Curves

Relative Intensity vs. Wavelength

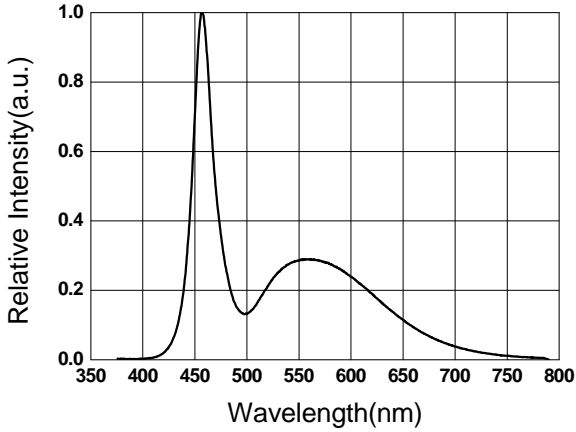

Forward Current vs. Forward Voltage

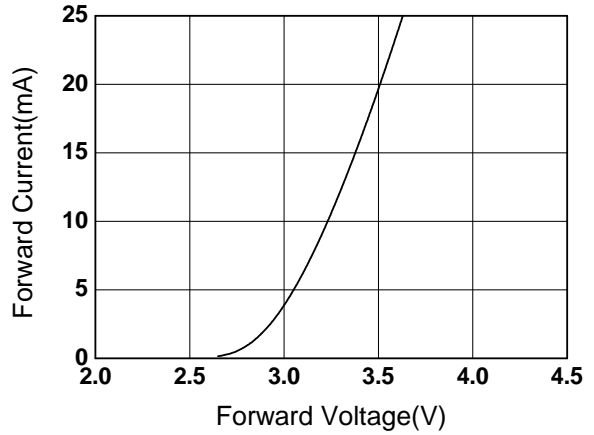

Relative Intensity vs. Forward Current

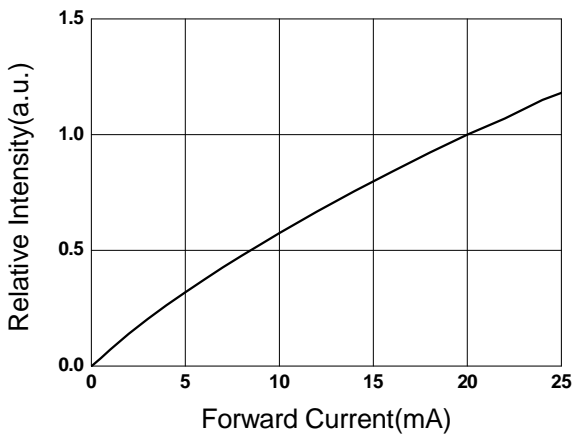

Forward Current vs. Ambient Temp.

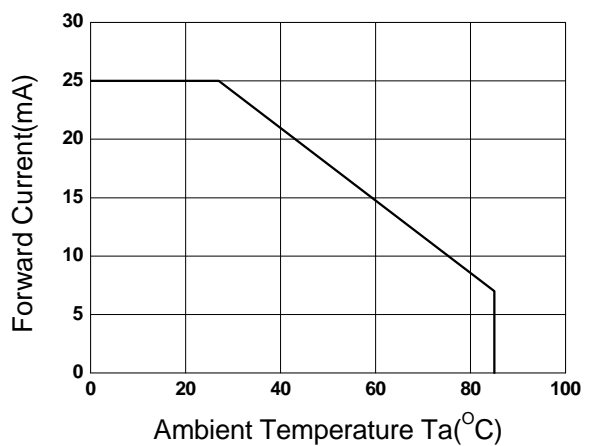

Chromaticity Coordinate vs. Forward Current

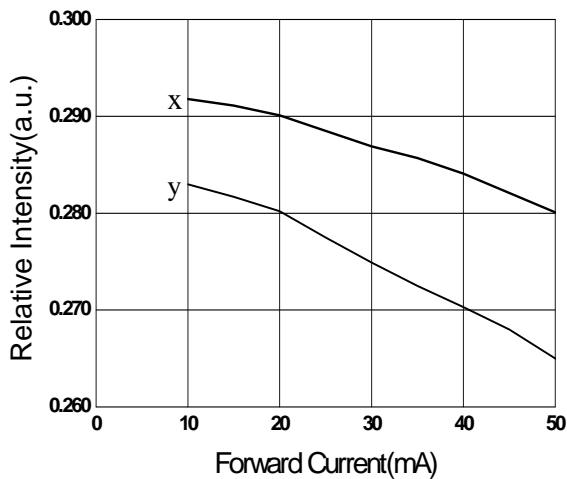

Relative Intensity vs. Angle Dispacemen

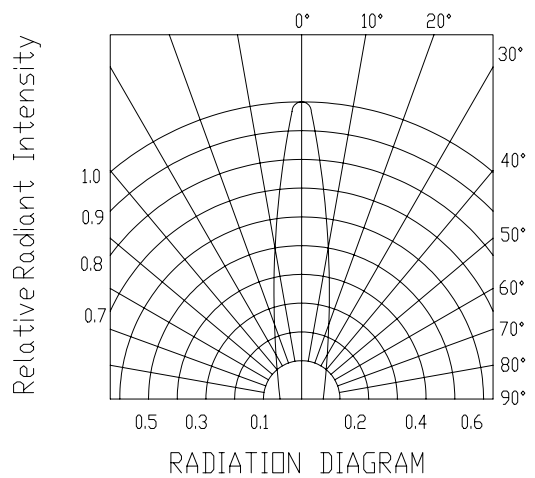



204-15UTC/C470

Label Form Specification

EVERLIGHT	
CPN:	
P/N:	
204-15UTC/C470	
QTY :	CAT:
LOT NO :	HUE:
	REF:
MADE IN TAIWAN	

CPN: Customer's Production Number
P/N : Production Number
QTY: Packing Quantity
CAT: IV&VF Rank
HUE: Color Rank
REF: Reference
LOT No: Lot Number
MADE IN TAIWAN: Production Place

Notes

1. Above specification may be changed without notice. EVERLIGHT will reserve authority on material change for above specification.
2. When using this product, please observe the absolute maximum ratings and the instructions for using outlined in these specification sheets. EVERLIGHT assumes no responsibility for any damage resulting from use of the product which does not comply with the absolute maximum ratings and the instructions included in these specification sheets.
3. These specification sheets include materials protected under copyright of EVERLIGHT corporation. Please don't reproduce or cause anyone to reproduce them without EVERLIGHT's consent.

EVERLIGHT ELECTRONICS CO., LTD. Office: No 25, Lane 76, Sec 3, Chung Yang Rd, Tucheng, Taipei 236, Taiwan, R.O.C	Tel: 886-2-2267-2000, 2267-9936 Fax: 886-2267-6244, 2267-6189, 2267-6306 http://www.everlight.com
---	--