

International
IR Rectifier

30BQ100PbF

SCHOTTKY RECTIFIER

3 Amp

$$I_{F(AV)} = 3.0\text{Amp}$$

$$V_R = 100\text{V}$$

Major Ratings and Characteristics

Characteristics	Value	Units
$I_{F(AV)}$ Rectangular waveform	3.0	A
V_{RRM}	100	V
I_{FSM} @ $t_p = 5\mu\text{s}$ sine	2100	A
V_F @ 3.0 Apk, $T_J = 125^\circ\text{C}$	0.62	V
T_J range	- 55 to 175	$^\circ\text{C}$

Description/ Features

The 30BQ100PbF surface-mount Schottky rectifier has been designed for applications requiring low forward drop and small foot prints on PC boards. Typical applications are in disk drives, switching power supplies, converters, free-wheeling diodes, battery charging, and reverse battery protection.

- Small foot print, surface mountable
- Very low forward voltage drop
- High frequency operation
- Guard ring for enhanced ruggedness and long term reliability
- Lead-Free ("PbF" suffix)

Case Styles

30BQ100PbF



SMC



Voltage Ratings

Part number	30BQ100PbF
V _R Max. DC Reverse Voltage (V)	100
V _{RWM} Max. Working Peak Reverse Voltage (V)	

Absolute Maximum Ratings

Parameters	30BQ	Units	Conditions
I _{F(AV)} Max. Average Forward Current	3.0	A	50% duty cycle @ T _L = 148 °C, rectangular wave form
	4.0		50% duty cycle @ T _L = 138 °C, rectangular wave form
I _{FSM} Max. Peak One Cycle Non-Repetitive Surge Current	800	A	5µs Sine or 3µs Rect. pulse
	70		10ms Sine or 6ms Rect. pulse
E _{AS} Non Repetitive Avalanche Energy	3.0	mJ	T _J = 25 °C, I _{AS} = 1.0A, L = 6mH
I _{AR} Repetitive Avalanche Current	0.5	A	Current decaying linearly to zero in 1 µsec Frequency limited by T _J max. Va = 1.5 x Vr typical

Electrical Specifications

Parameters	30BQ	Units	Conditions
V _{FM} Max. Forward Voltage Drop (1)	0.79	V	@ 3A T _J = 25 °C
	0.90	V	@ 6A
	0.62	V	@ 3A T _J = 125 °C
	0.70	V	@ 6A
I _{RM} Max. Reverse Leakage Current (1)	0.5	mA	T _J = 25 °C V _R = rated V _R
	5.0	mA	T _J = 125 °C
C _T Max. Junction Capacitance	115	pF	V _R = 5V _{DC} (test signal range 100KHz to 1Mhz) 25°C
L _S Typical Series Inductance	3.0	nH	Measured lead to lead 5mm from package body
dv/dt Max. Voltage Rate of Change	10000	V/µs	(Rated V _R)

(1) Pulse Width < 300µs, Duty Cycle < 2%

Thermal-Mechanical Specifications

Parameters	30BQ	Units	Conditions
T _J Max. Junction Temperature Range (*)	-55 to 175	°C	
T _{stg} Max. Storage Temperature Range	-55 to 175	°C	
R _{thJL} Max. Thermal Resistance Junction to Lead (**)	12	°C/W	DC operation
R _{thJA} Max. Thermal Resistance Junction to Ambient	46	°C/W	DC operation
wt Approximate Weight	0.24 (0.008)	g (oz.)	
Case Style	SMC		Similar to DO-214AB
Device Marking	IR3J		

(*) $\frac{dP_{tot}}{dT_J} < \frac{1}{R_{th(j-a)}}$ thermal runaway condition for a diode on its own heatsink

(**) Mounted 1 inch square PCB

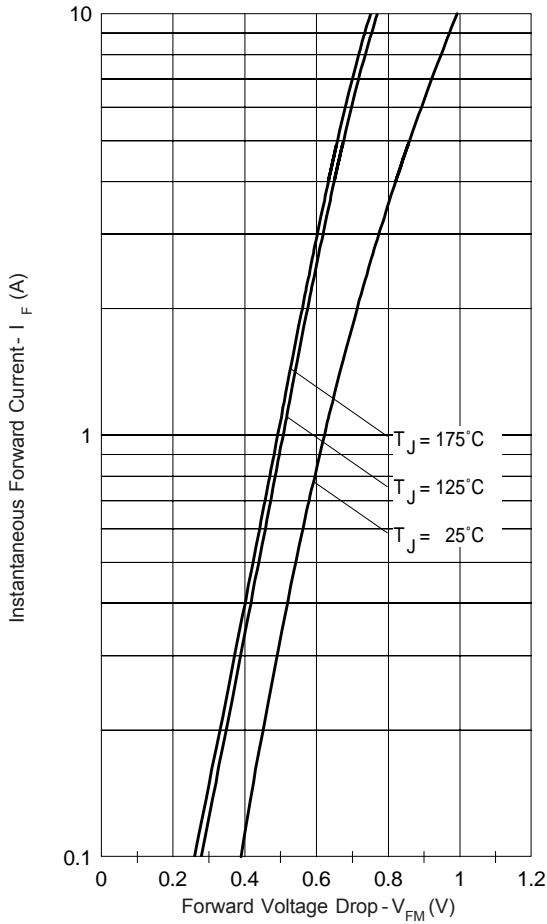

Fig. 1 - Max. Forward Voltage Drop Characteristics (Per Leg)

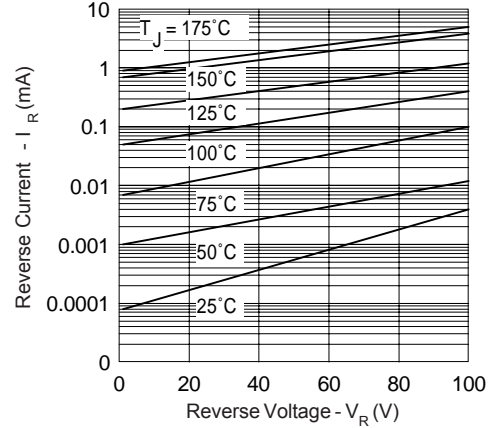

Fig. 2 - Typical Values Of Reverse Current Vs. Reverse Voltage (Per Leg)

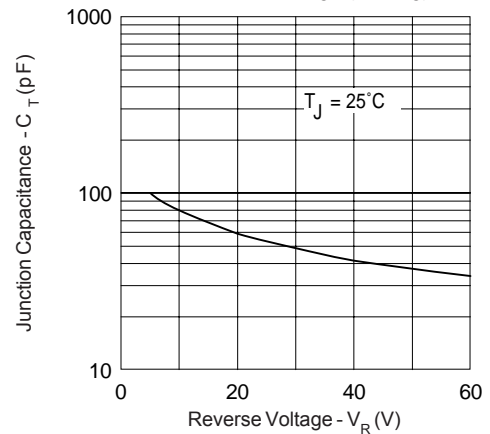

Fig. 3 - Typical Junction Capacitance Vs. Reverse Voltage (Per Leg)

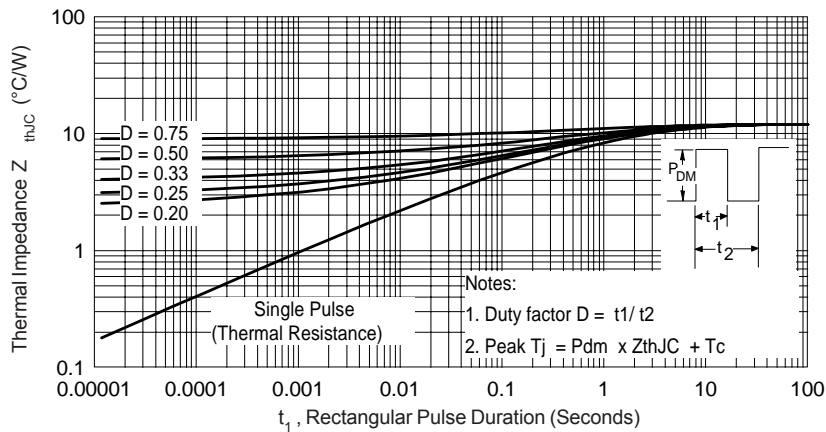

Fig. 4 - Max. Thermal Impedance Z_{thJC} Characteristics (Per Leg)

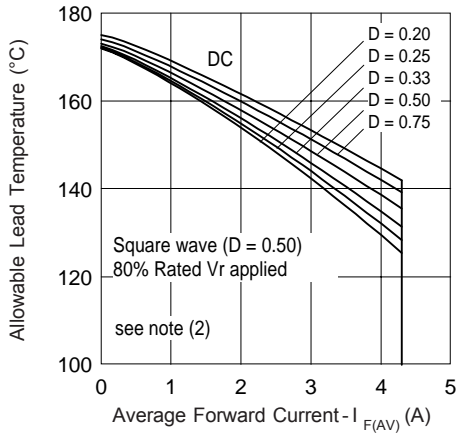

Fig. 4 - Maximum Average Forward Current Vs. Allowable Lead Temperature

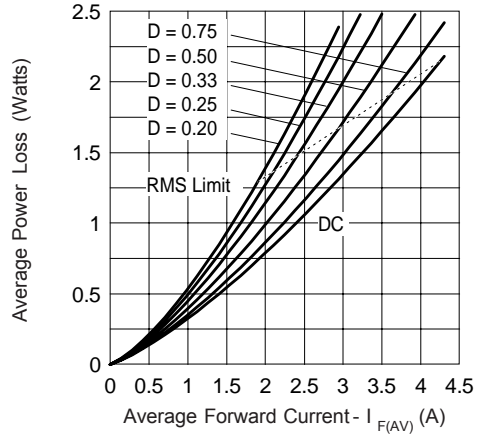

Fig. 5 - Maximum Average Forward Dissipation Vs. Average Forward Current

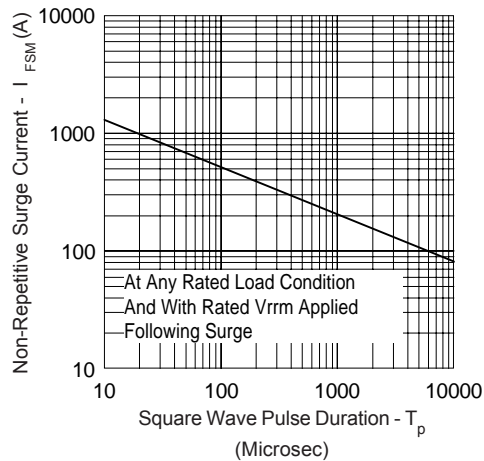

Fig. 6 - Maximum Peak Surge Forward Current Vs. Pulse Duration

(2) Formula used: $T_C = T_J - (Pd + Pd_{REV}) \times R_{thJC}$;

Pd = Forward Power Loss = $I_{F(AV)} \times V_{FM} @ (I_{F(AV)} / D)$ (see Fig. 6);

Pd_{REV} = Inverse Power Loss = $V_{R1} \times I_R (1 - D)$; $I_R @ V_{R1} = 80\%$ rated V_R

Outline Table

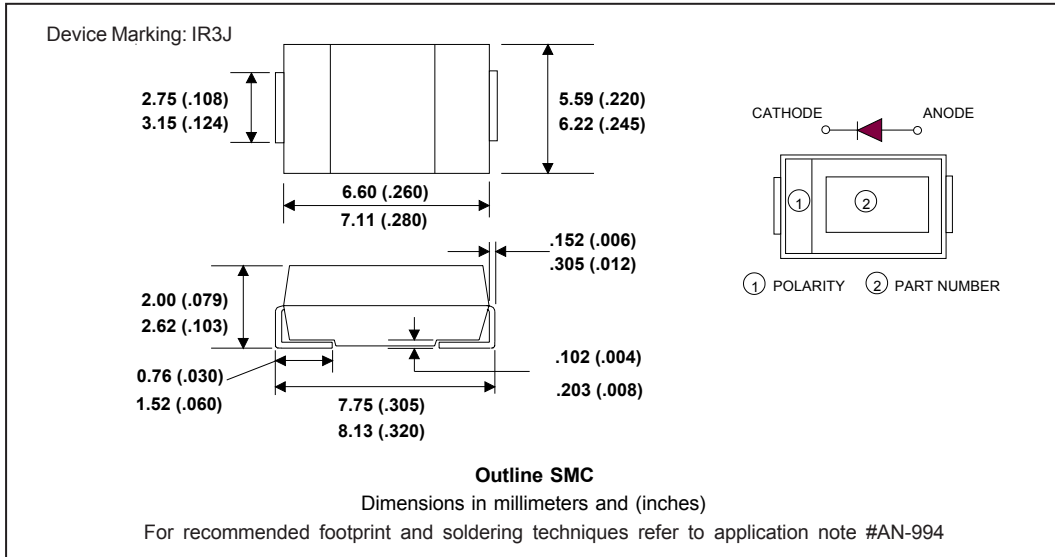

Marking & Identification

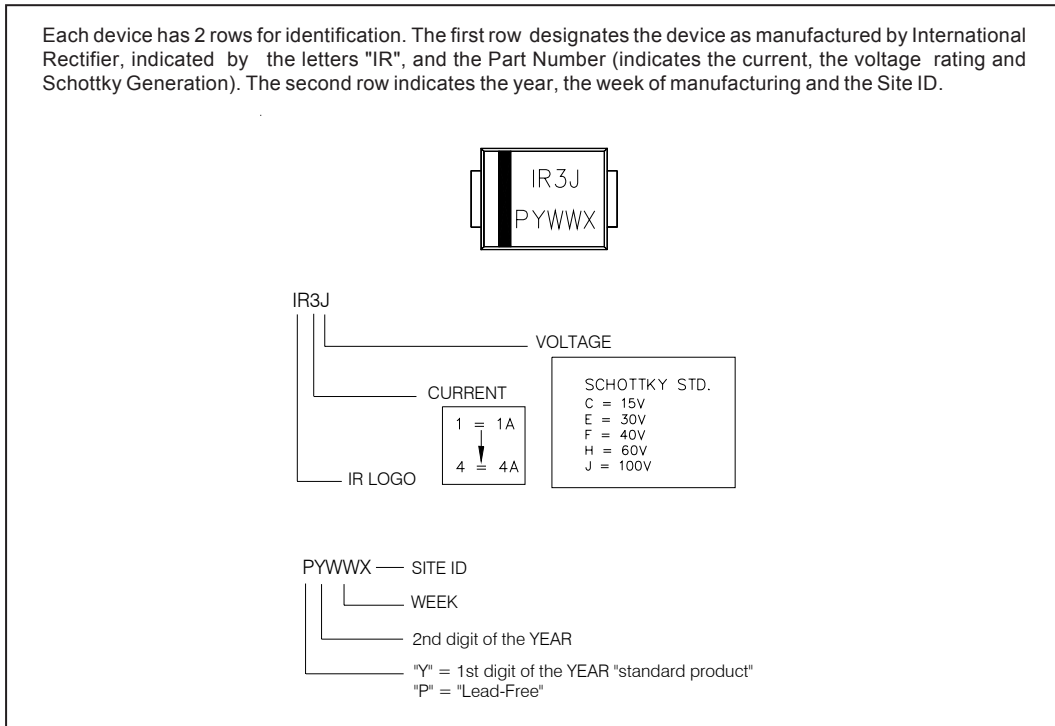

Tape & Reel Information

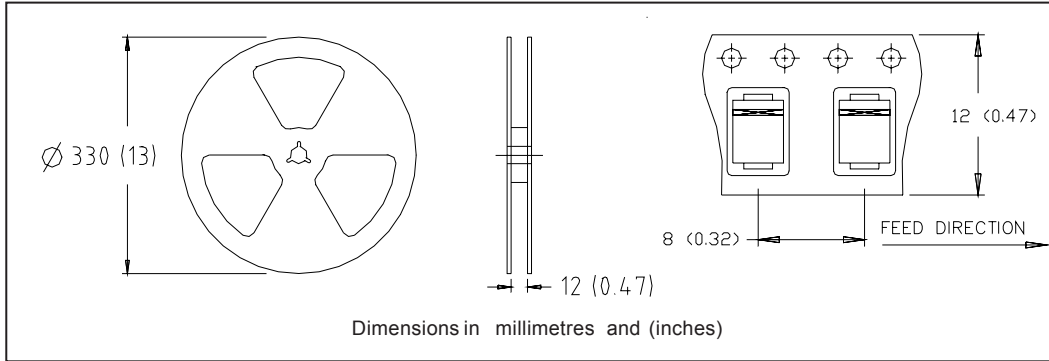

Ordering Information Table

Device Code	30	B	Q	100	TR	PbF
	①	②	③	④	⑤	⑥
1	- Current Rating					
2	- B = Single Lead Diode					
3	- Q = Schottky Q Series					
4	- Voltage Rating (100 = 100V)					
5	- • none = Box (1000 pieces) • TR = Tape & Reel (3000 pieces)					
6	- • none = Standard Production • PbF = Lead-Free					

Data and specifications subject to change without notice.
This product has been designed and qualified for Industrial Level and Lead-Free.
Qualification Standards can be found on IR's Web site.