

Technical Data Sheet**Luminosity Full Color LED****61-23 RGBC/TR8****Features**

- Super-luminosity chip LED.
- White SMT package.
- Built in Red, Green, and Blue chips.
- Lead frame package with individual 6 pins.
- Wide viewing angle.
- Soldering methods: IR reflow soldering.
- Pb-free.

Descriptions

- Due to the package design, 61-23 has wide viewing angle , low power consumption and adjusting each color is possible thanks to serial connection by 6 terminal connection (Individual driving by each terminal) in case of using several number of LED. And makes it ideal for light pipe application.

Applications

- Amusement equipment.
- Information boards.
- Flashlight for digital camera of cellular phone.

**Device Selection Guide**

Chip			Lens Color
Type	Material	Emitted Color	
R	AlGaInP	Super Sunset Orange	Water Clear
G	InGaN	Super Green	
B	InGaN	Super Blue	

Package Outline Dimensions

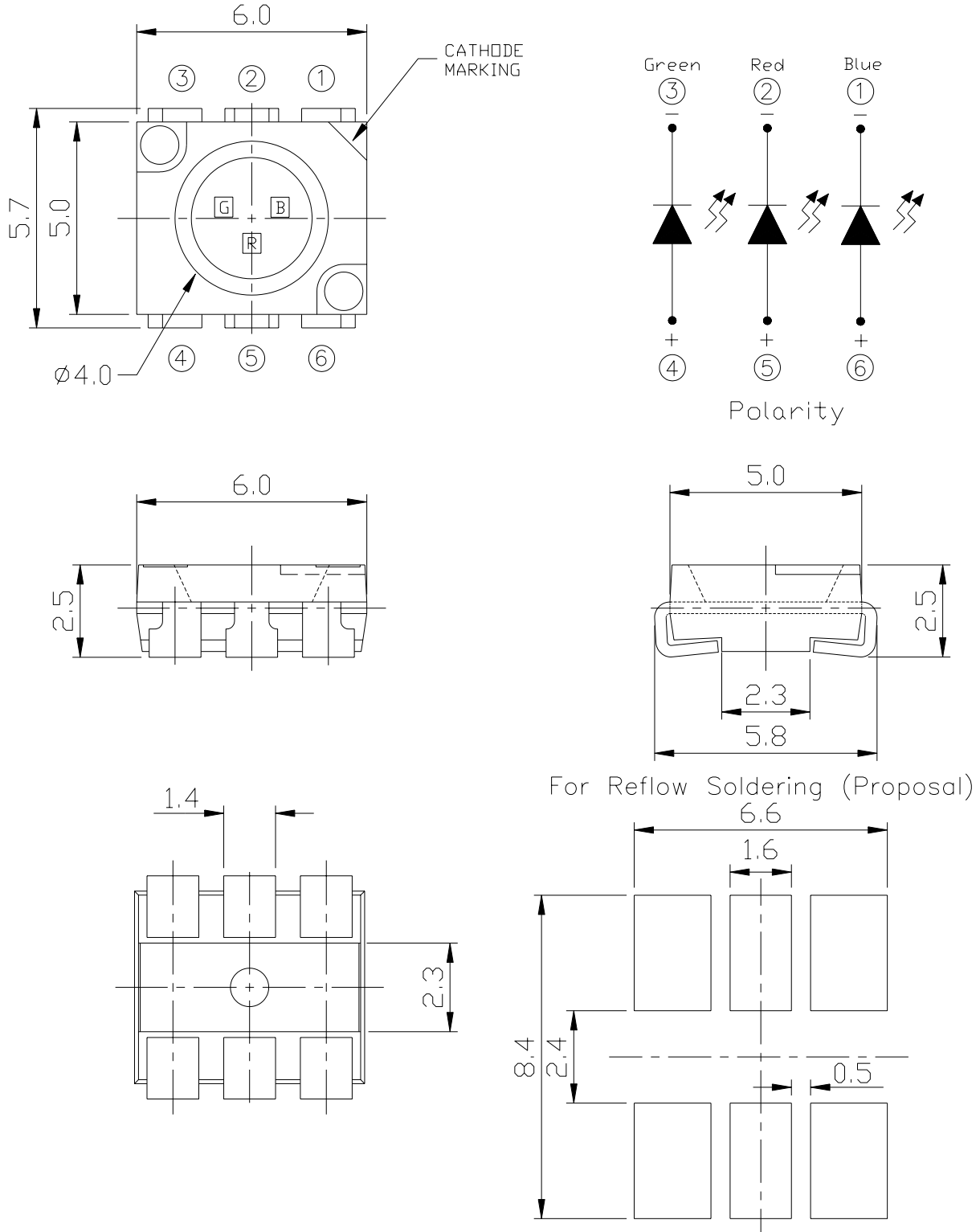

Notes: 1.All dimensions are in millimeters. 2.Tolerances unspecified are ± 0.1 mm.

Absolute Maximum Ratings (Ta=25°C)

Parameter	Symbol	Rating		Unit
Reverse Voltage	V _R	5		V
Operating Temperature	T _{opr}	-40 ~ +85		°C
Storage Temperature	T _{stg}	-40~ +100		°C
Soldering Temperature	T _{sol}	260 (for 5 second)		°C
Electrostatic Discharge	ESD	R	2000	V
		G	150	
		B	150	
Power Dissipation	P _d	110		mW
Forward Current	I _F	R	40	mA
		G	40	
		B	40	
Peak Forward Current(Duty 1/10 @ 1KHz)	I _{FP}	R	100	mA
		G	100	
		B	100	

Electro-Optical Characteristics (Ta=25°C)

Parameter	Symbol	Min.	Typ.	Max.	Unit	Condition	
Luminous Intensity	I _v	R	-----	1725	-----	mcd	I _F =40mA
		G					I _F =40mA
		B					I _F =20mA
Viewing Angle	2θ _{1/2}	-----	120	-----	deg	I _F =40mA	
Peak Wavelength	λ _p	R	-----	621	-----	nm	I _F =40mA
		G	-----	518	-----		
		B	-----	468	-----		
Dominant Wavelength	λ _d	R	-----	615	-----	nm	I _F =40mA
		G	-----	525	-----		
		B	-----	470	-----		
Spectrum Radiation Bandwidth	Δλ	R	-----	18	-----	nm	I _F =40mA
		G	-----	35	-----		
		B	-----	35	-----		
Forward Voltage	V _F	R	-----	2.3	2.9	V	I _F =35mA
		G	-----	4.6	5.2		
		B	-----	4.6	5.2		
Reverse Current	I _R	R	-----	-----	10	μA	V _R =5V
		G	-----	-----	50		
		B	-----	-----	50		

Typical Electro-Optical Characteristics Curves (Blue)

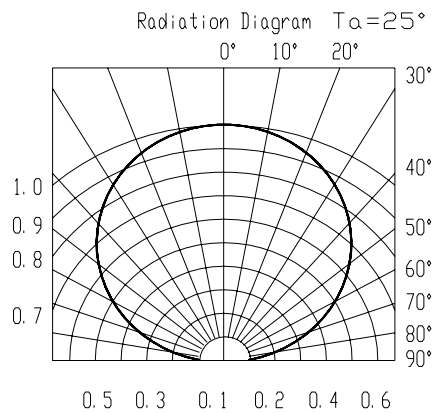
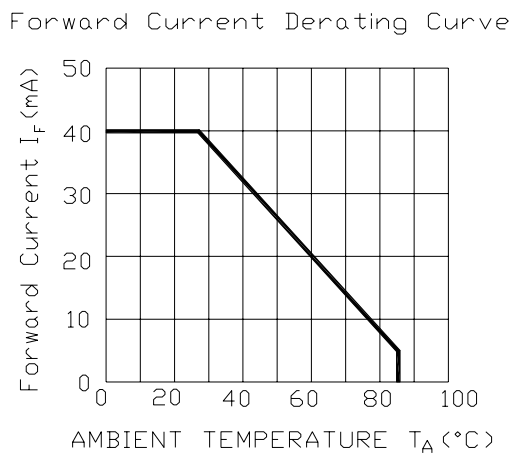
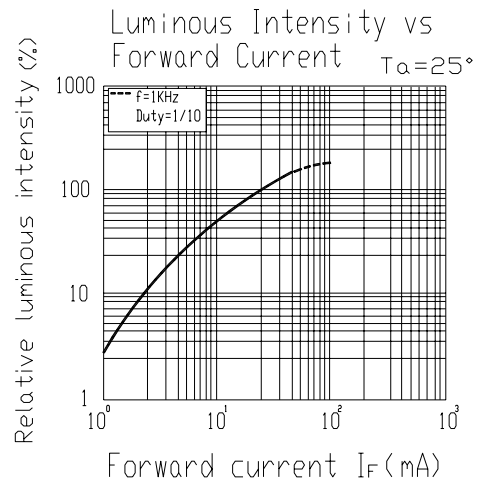
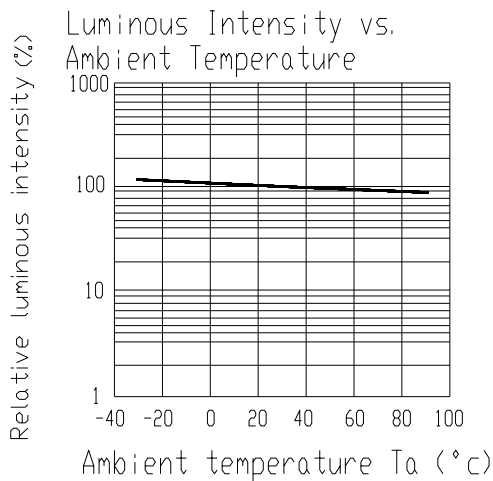
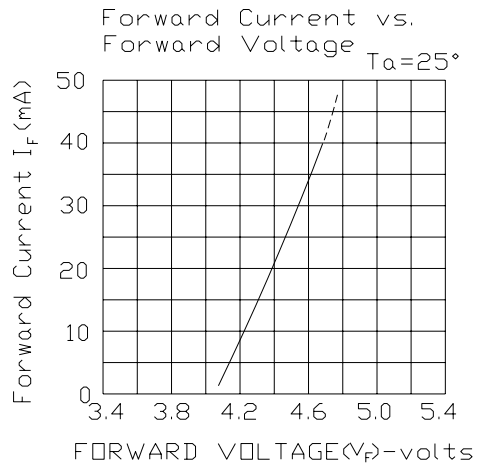
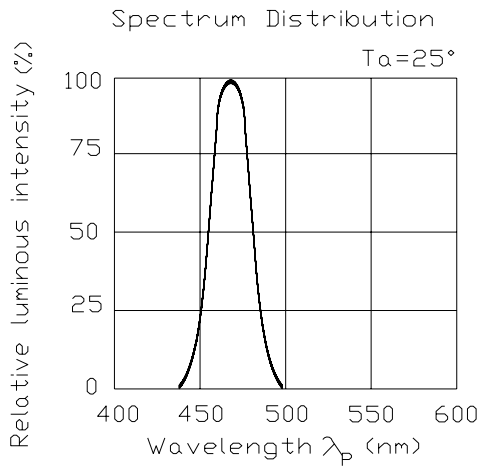

61-23 RGBC/TR8

Typical Electro-Optical Characteristics Curves (Red)

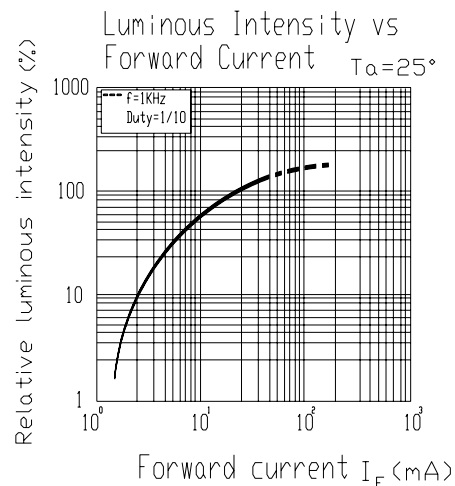
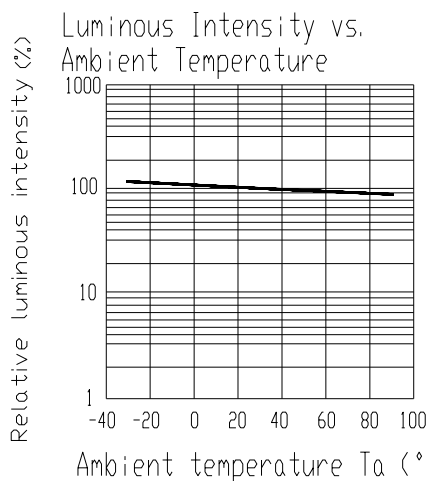
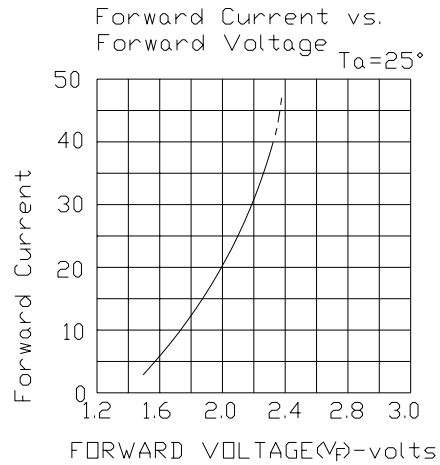
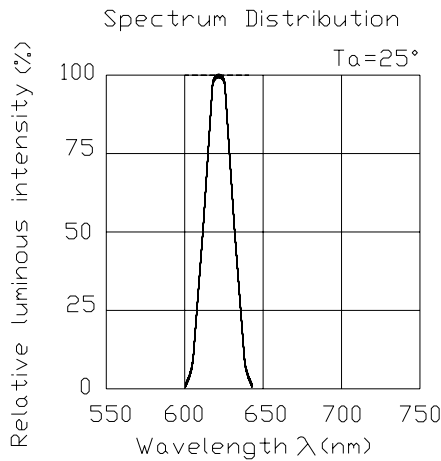

Forward Current Derating Curve

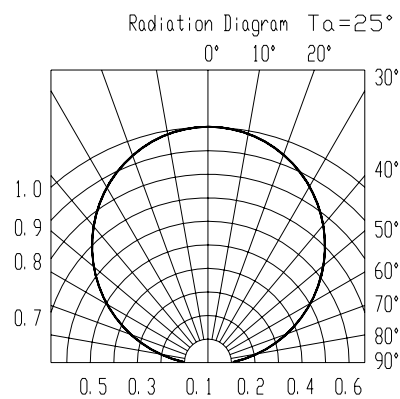
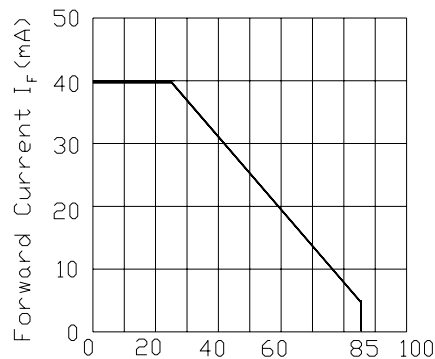

Typical Electro-Optical Characteristics Curves (Green)

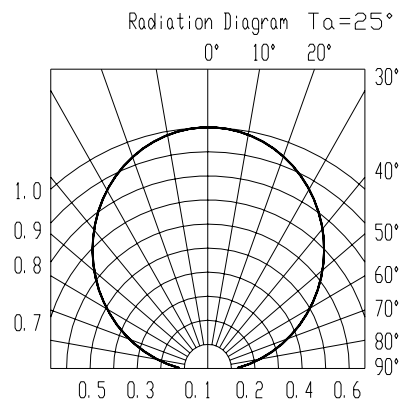
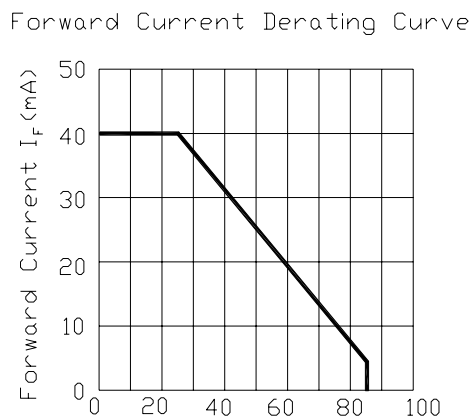
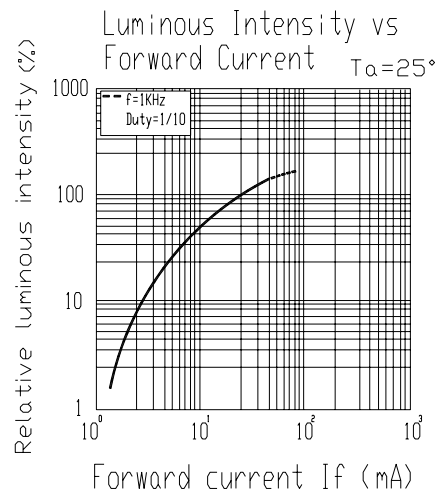
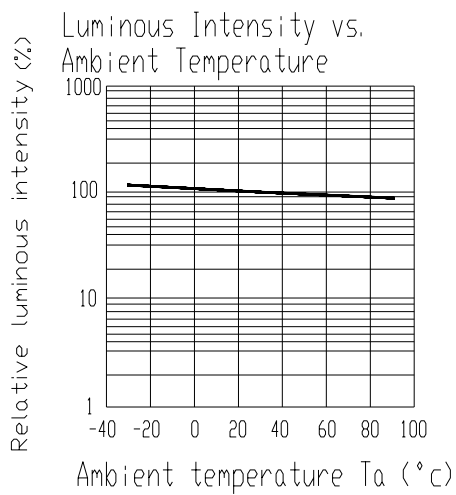
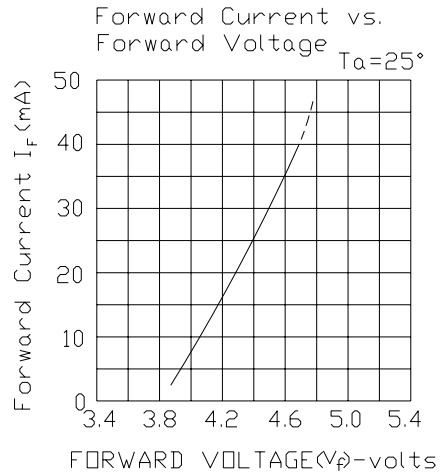
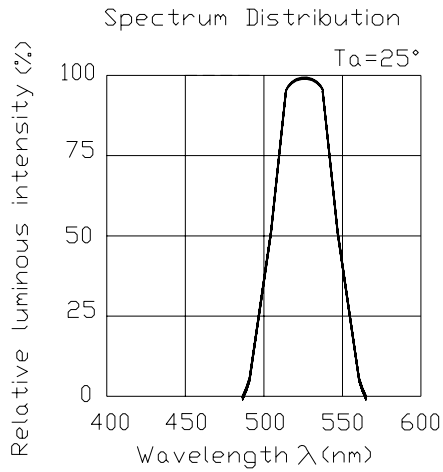

Label explanation

CAT: Luminous Intensity Rank

HUE: Dom. Wavelength Rank

REF: Forward Voltage Rank



Reel Dimensions

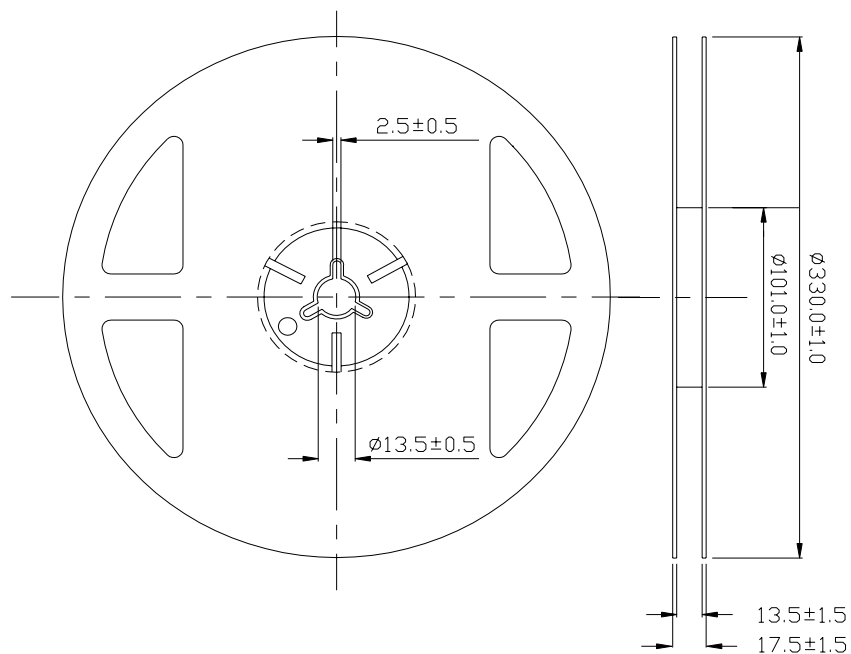

Note: The tolerances unless mentioned is ±0.1mm ,Unit = mm

Loaded quantity per reel 800 PCS/reel

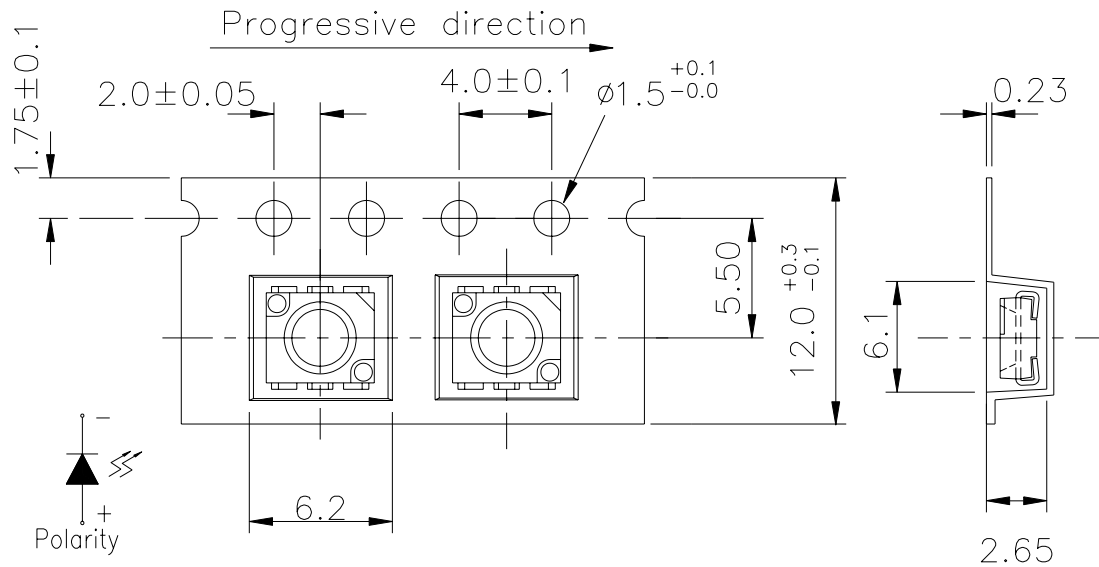

Note: The tolerances unless mentioned is ± 0.1 mm , Angle $\pm 0.5^\circ$,Unit = mm

Moisture Resistant Packaging

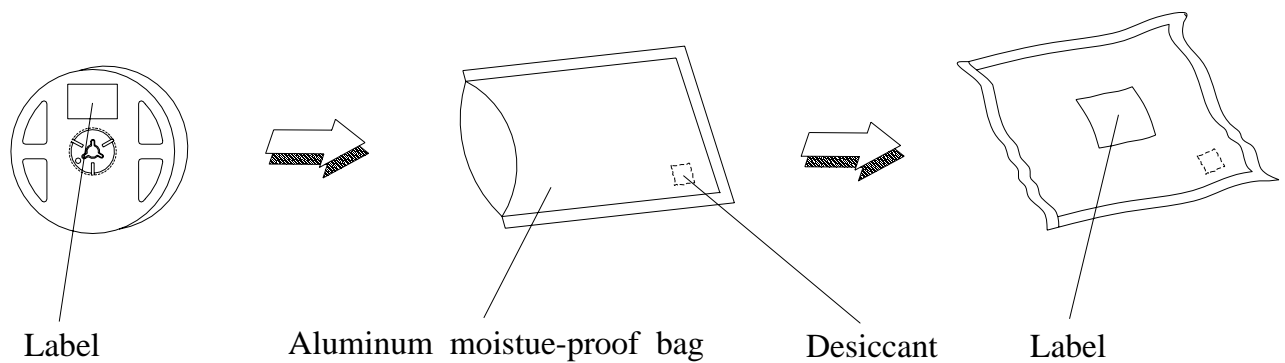

61-23 RGBC/TR8

Reliability Test Items And Conditions

The reliability of products shall be satisfied with items listed below.

Confidence level : 90%

LTPD : 10%

No.	Items	Test Condition	Test Hours/Cycles	Sample Size	Ac/Re
1	Reflow Soldering	Temp. : 260°C ±5°C Min. 5sec.	6 Min.	22 PCS.	0/1
2	Temperature Cycle	H : +100°C 15min ∫ 5 min L : -40°C 15min	300 Cycles	22 PCS.	0/1
3	Thermal Shock	H : +100°C 5min ∫ 10 sec L : -10°C 5min	300 Cycles	22 PCS.	0/1
4	High Temperature Storage	Temp. : 100°C	1000 Hrs.	22 PCS.	0/1
5	Low Temperature Storage	Temp. : -40°C	1000 Hrs.	22 PCS.	0/1
6	DC Operating Life	IF = 20 mA	1000 Hrs.	22 PCS.	0/1
7	High Temperature / High Humidity	85°C / 85%RH	1000 Hrs.	22 PCS.	0/1

Precautions For Use**1. Over-current-proof**

Customer must apply resistors for protection , otherwise slight voltage shift will cause big current change (Burn out will happen).

2. Storage

2.1 Do not open moisture proof bag before the products are ready to use.

2.2 Before opening the package, the LEDs should be kept at 30°C or less and 90%RH or less.

2.3 The LEDs should be used within a year.

2.4 After opening the package, the LEDs should be kept at 30°C or less and 70%RH or less.

2.5 The LEDs should be used within 168 hours (7 days) after opening the package.

2.6 If the moisture absorbent material (silica gel) has faded away or the LEDs have exceeded the storage time, baking treatment should be performed using the following conditions.

Baking treatment : 60±5°C for 24 hours.

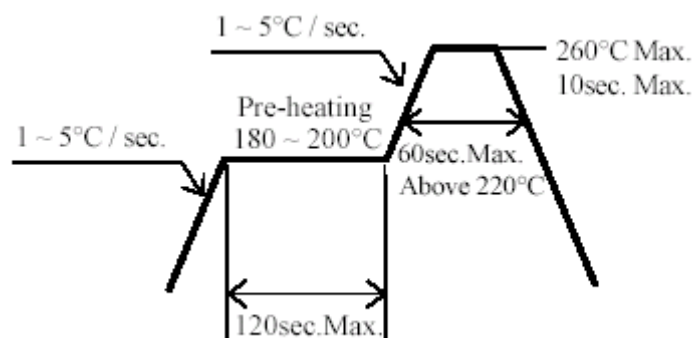
3. Soldering Condition**3.1 Pb-free solder temperature profile**

3.2 Reflow soldering should not be done more than two times.

3.3 When soldering, do not put stress on the LEDs during heating.

3.4 After soldering, do not warp the circuit board.

61-23 RGBC/TR8**4.Soldering Iron**

Each terminal is to go to the tip of soldering iron temperature less than 280°C for 3 seconds within once in less than the soldering iron capacity 25W. Leave two seconds and more intervals, and do soldering of each terminal. Be careful because the damage of the product is often started at the time of the hand solder.

5.Repairing

Repair should not be done after the LEDs have been soldered. When repairing is unavoidable, a double-head soldering iron should be used (as below figure). It should be confirmed beforehand whether the characteristics of the LEDs will or will not be damaged by repairing.

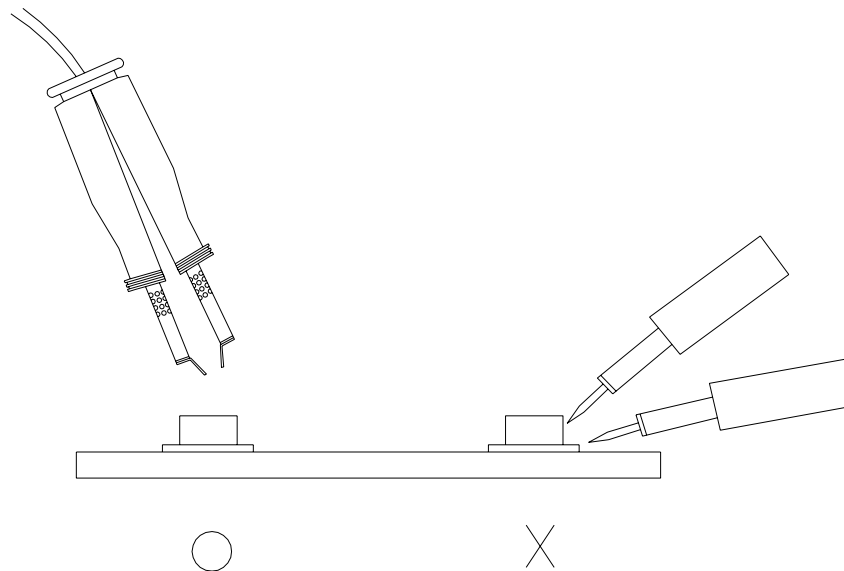

EVERLIGHT ELECTRONICS CO., LTD.
Office: No 25, Lane 76, Sec 3, Chung Yang Rd,
Tucheng, Taipei 236, Taiwan, R.O.C

Tel: 886-2-2267-2000, 2267-9936
Fax: 886-2267-6244, 2267-6189, 2267-6306
<http://www.everlight.com>