

Technical Data Sheet**Luminosity white Color LED****61-25UWC/S400-A6/TR8****Features**

- Super luminosity white LED.
- White SMT package.
- Built in 5 LED chips.
- Lead frame package with individual 6 pins.
- Wide viewing angle.
- Soldering methods: Reflow soldering.
- High performance.
- Pb-free.

Descriptions

- Due to the package design, 61-25 has wide viewing angle, low power consumption and high luminous intensity. This feature makes it ideal for light pipe or lighting application.

**Applications**

- Amusement equipment.
- Information boards.
- Flashlight for digital camera of cellular phone.
- Lighting for small size device.

Device Selection Guide

Chip		Lens Color
Material	Emitted Color	
InGaN	White	Water Clear

Package Outline Dimensions

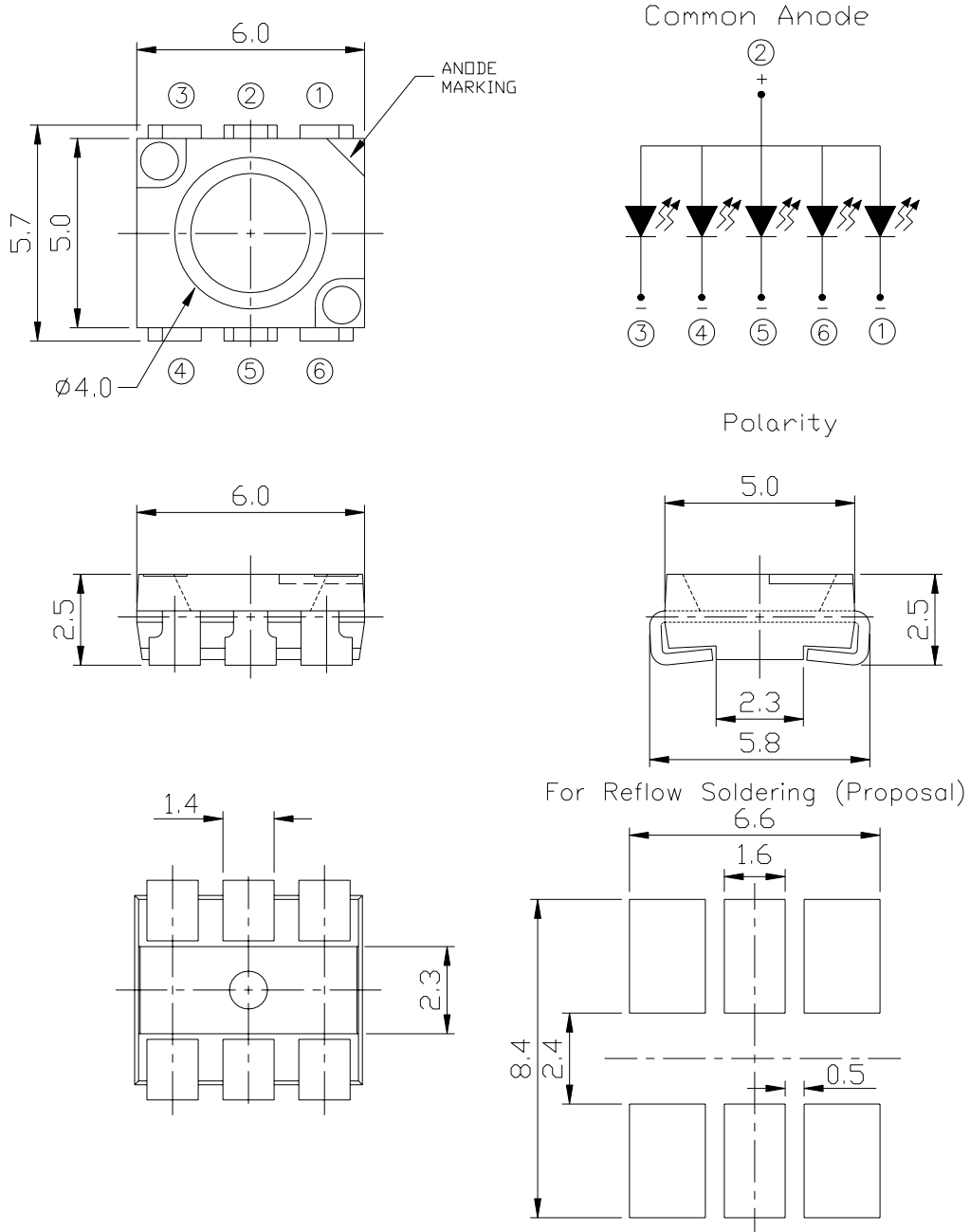

Notes: 1.All dimensions are in millimeters. 2.Tolerances unspecified are ± 0.1 mm.

Absolute Maximum Ratings (Ta=25°C)

Parameter	Symbol	Rating	Unit
Reverse Voltage	V _R	5	V
Operating Temperature	T _{opr}	-40 ~ +85	°C
Storage Temperature	T _{stg}	-40~ +100	°C
Soldering Temperature	T _{sol}	260 (for 5 second)	°C
Electrostatic Discharge	ESD	150	V
Power Dissipation	P _d	110	mW
*Forward Current	I _F	25	mA
*Peak Forward Current(Duty 1/10 @ 1KHz)	I _{FP}	100	mA

*. Maximum forward current for each die.

Electro-Optical Characteristics (Ta=25°C)

Parameter	Symbol	Min.	Typ.	Max.	Unit	Condition
Luminous Intensity*1	I _V	1500	2000	-----	mcd	I _F =20mA
Viewing Angle*2	2θ _{1/2}	-----	120	-----	deg	I _F =20mA
Forward Voltage*2	V _F	-----	3.5	4.0	V	I _F =20mA
Reverse Current	I _R	-----	-----	50	μA	V _R =5V

*1 When five LED dies are operated simultaneously.

*2 For each die.

The products are sensitive to static electricity and care must be fully taken when handling products.

61-25UWC/S400-A6/TR8

Color Ranks

	Rank a0			
x	0.280	0.264	0.283	0.296
y	0.248	0.267	0.305	0.276

	Rank b2			
x	0.296	0.287	0.330	0.330
y	0.276	0.295	0.339	0.318

	Rank b1			
x	0.287	0.283	0.330	0.330
y	0.295	0.305	0.360	0.339

	Rank c0			
x	0.330	0.330	0.361	0.356
y	0.318	0.360	0.385	0.351

*The C.I.E. 1931 color rank (Tolerance ± 0.01).

CIE Chromaticity Diagram

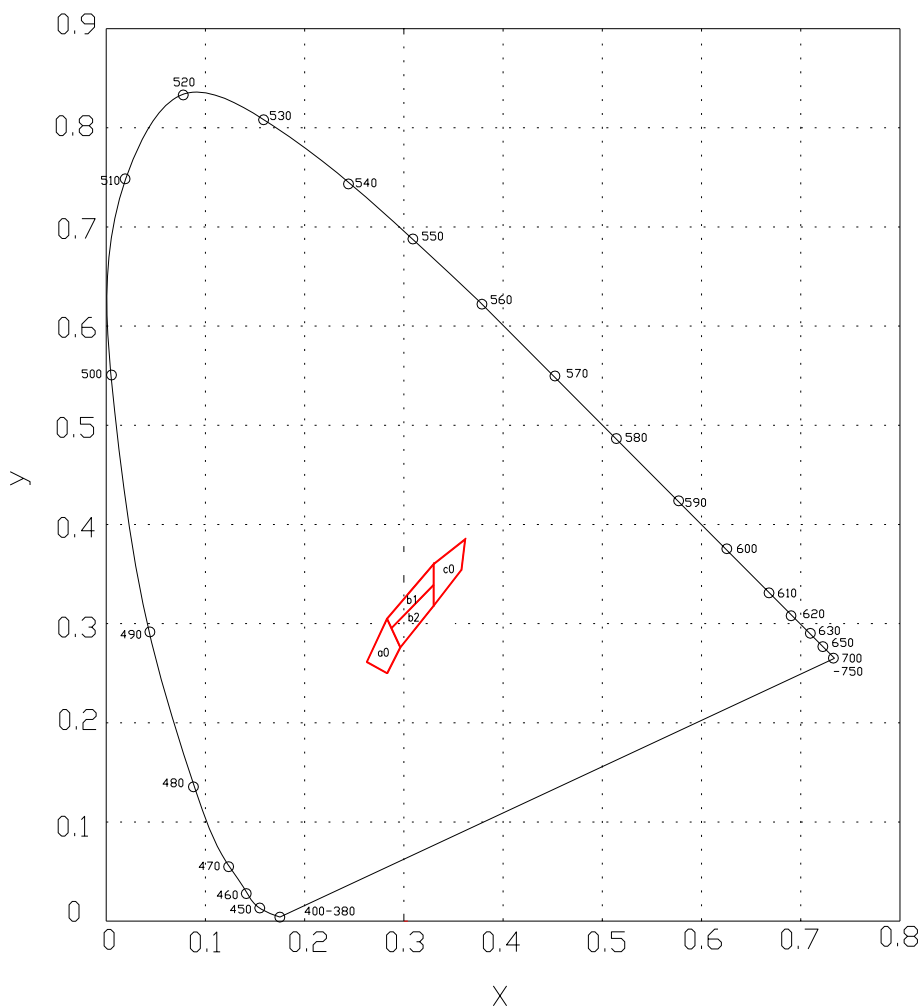

Typical Electro-Optical Characteristics Curves

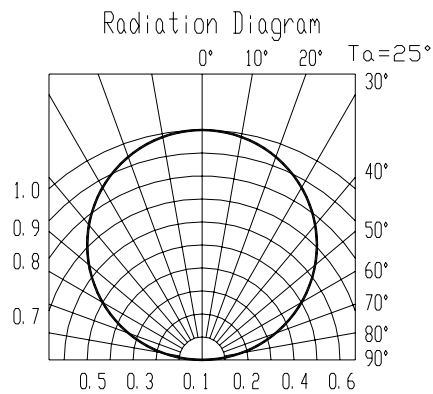
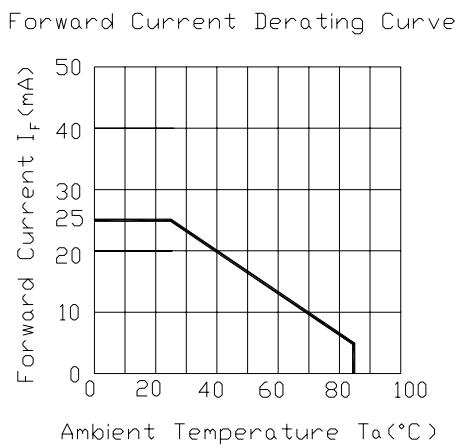
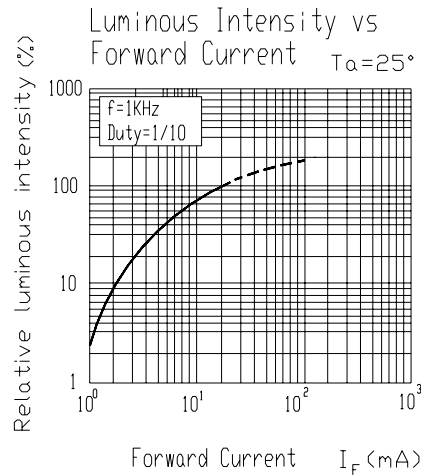
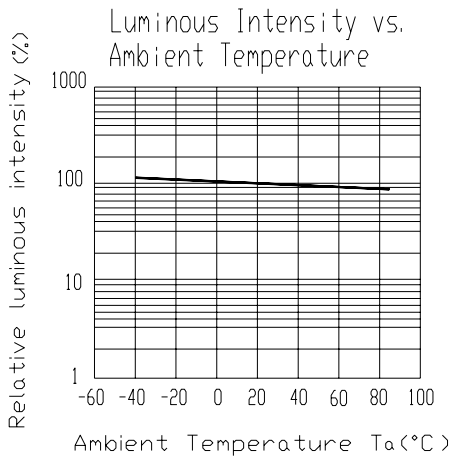
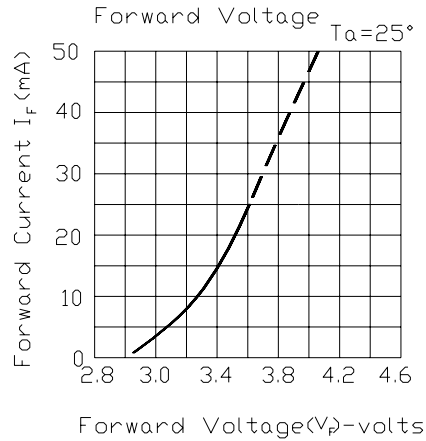
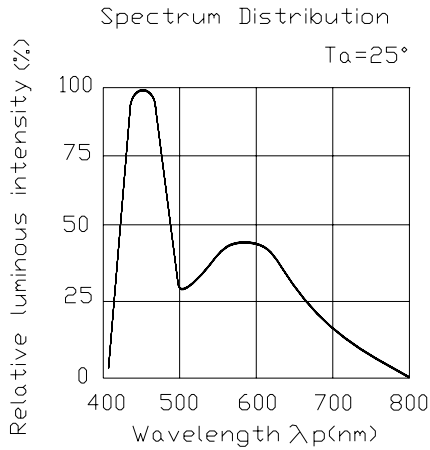

61-25UWC/S400-A6/TR8

Label explanation

CAT: Luminous Intensity Rank

HUE: Chromaticity Coordinates

REF: Forward Voltage Rank

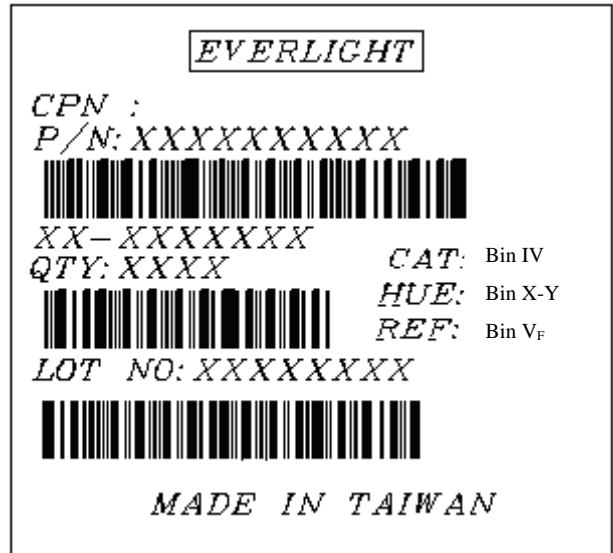

Reel Dimensions

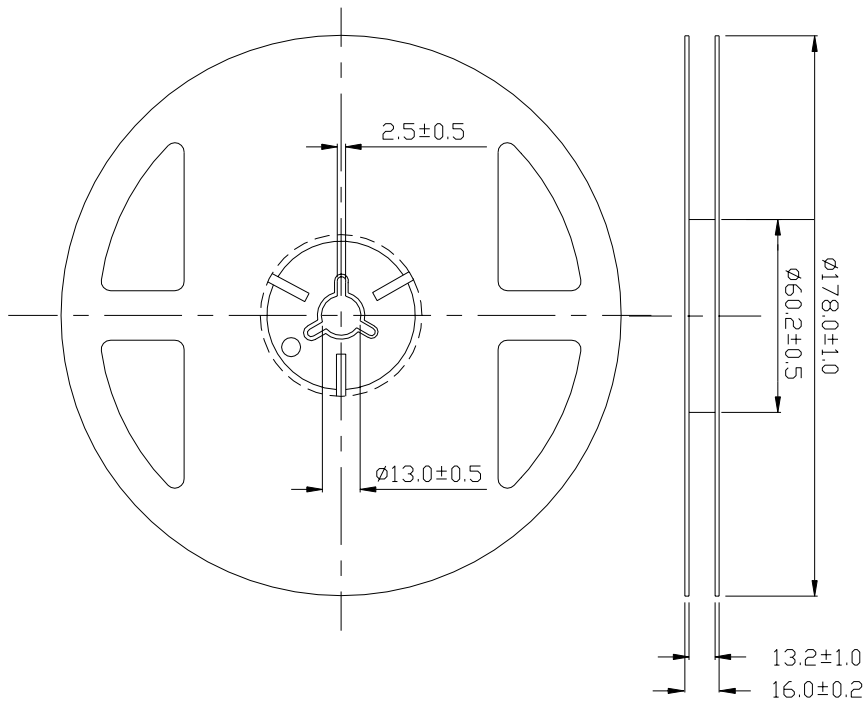

Taping Quantity: 800pcs

Note: The tolerances unless mentioned is ±0.1mm, Unit = mm

Carrier Tape Dimensions

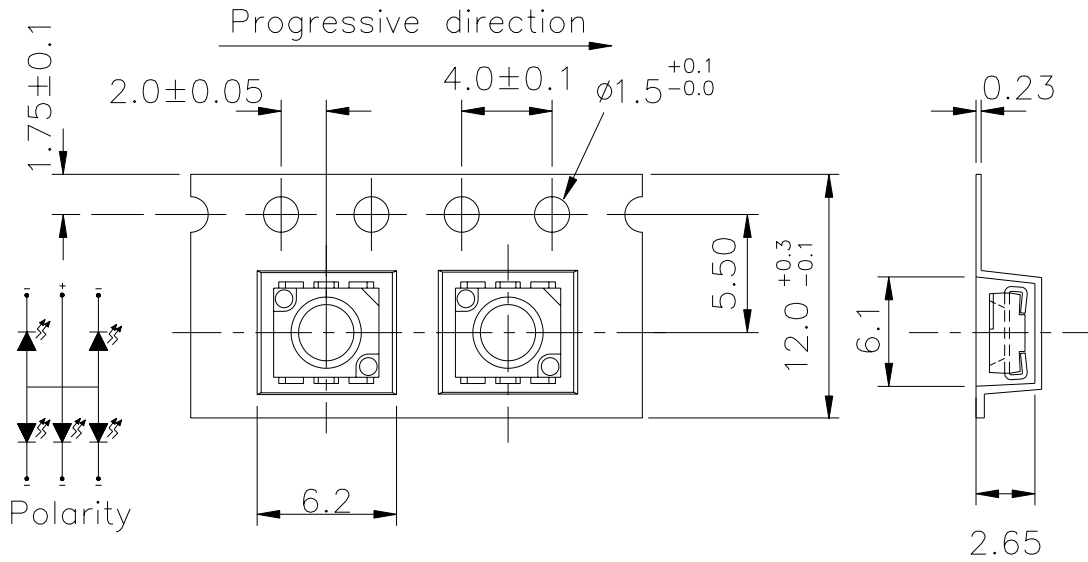

Note: The tolerances unless mentioned is ± 0.1 mm, Unit = mm

Moisture Resistant Packaging

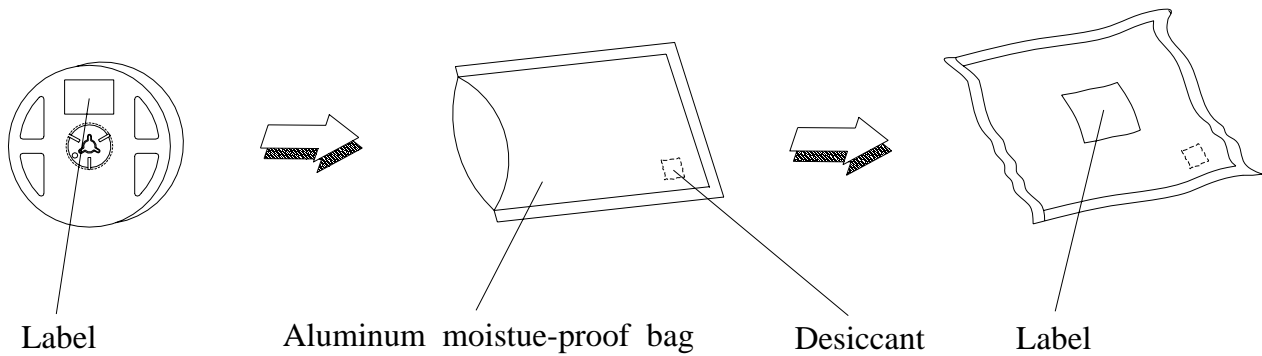

61-25UWC/S400-A6/TR8

Reliability Test Items And Conditions

The reliability of products shall be satisfied with items listed below.

Confidence level : 90%

LTPD : 10%

No.	Items	Test Condition	Test Hours/Cycles	Sample Size	Ac/Re
1	Reflow Soldering	Temp. : 260°C ±5°C Min. 5sec.	6 Min.	22 PCS.	0/1
2	Temperature Cycle	H : +100°C 15min ∫ 5 min L : -40°C 15min	300 Cycles	22 PCS.	0/1
3	Thermal Shock	H : +100°C 5min ∫ 10 sec L : -10°C 5min	300 Cycles	22 PCS.	0/1
4	High Temperature Storage	Temp. : 100°C	1000 Hrs.	22 PCS.	0/1
5	Low Temperature Storage	Temp. : -40°C	1000 Hrs.	22 PCS.	0/1
6	DC Operating Life	IF = 20 mA	1000 Hrs.	22 PCS.	0/1
7	High Temperature / High Humidity	85°C / 85%RH	1000 Hrs.	22 PCS.	0/1

Precautions For Use

1. Over-current-proof

Customer must apply resistors for protection , otherwise slight voltage shift will cause big current change (Burn out will happen).

2. Storage

2.1 Do not open moisture proof bag before the products are ready to use.

2.2 Before opening the package, the LEDs should be kept at 30°C or less and 90%RH or less.

2.3 The LEDs should be used within a year.

2.4 After opening the package, the LEDs should be kept at 30°C or less and 70%RH or less.

2.5 The LEDs should be used within 168 hours (7 days) after opening the package.

2.6 If the moisture absorbent material (silica gel) has faded away or the LEDs have exceeded the storage time, baking treatment should be performed using the following conditions.

Baking treatment : 60±5°C for 24 hours.

3. Soldering Condition

3.1 Pb-free solder temperature profile

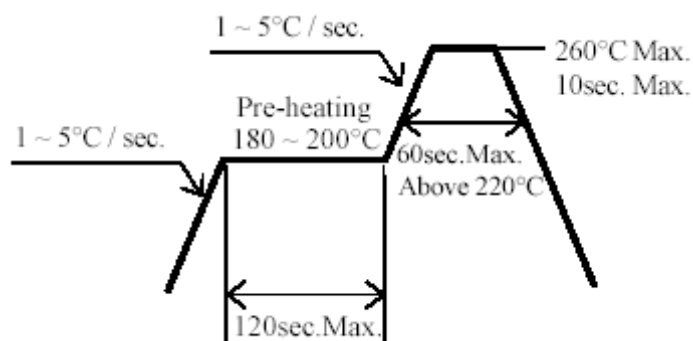

3.2 Reflow soldering should not be done more than two times.

3.3 When soldering, do not put stress on the LEDs during heating.

3.4 After soldering, do not warp the circuit board.

4. Soldering Iron

Each terminal is to go to the tip of soldering iron temperature less than 280°C for 3 seconds within once in less than the soldering iron capacity 25W. Leave two seconds and more intervals, and do soldering of each terminal. Be careful because the damage of the product is often started at the time of the hand solder.

5.Repairing

Repair should not be done after the LEDs have been soldered. When repairing is unavoidable, a double-head soldering iron should be used (as below figure). It should be confirmed beforehand whether the characteristics of the LEDs will or will not be damaged by repairing.

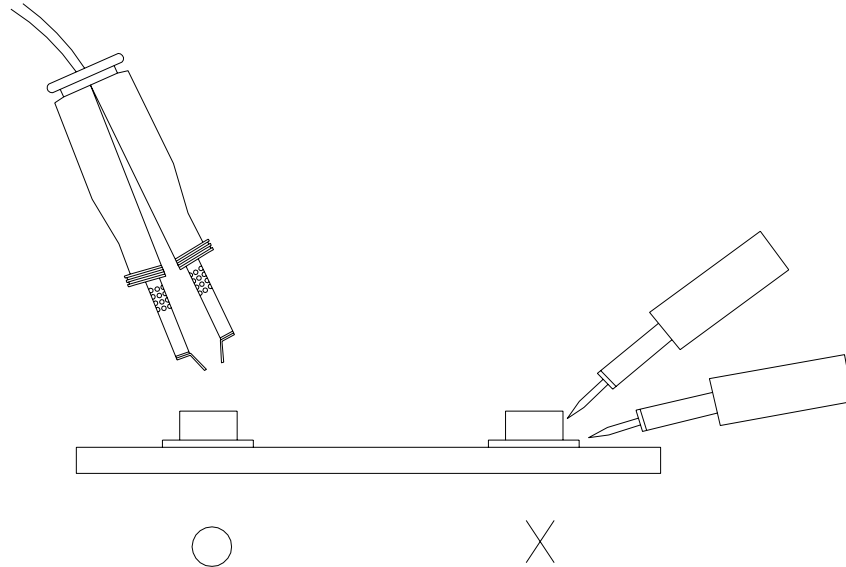

EVERLIGHT ELECTRONICS CO., LTD.
Office: No 25, Lane 76, Sec 3, Chung Yang Rd,
Tucheng, Taipei 236, Taiwan, R.O.C

Tel: 886-2-2267-2000, 2267-9936
Fax: 886-2267-6244, 2267-6189, 2267-6306
<http://www.everlight.com>