

DISPLAY Elektronik GmbH

DATA SHEET

LCD MODULE

DEM 20231 SYH-PY-CYR22

Product specification

Version : 2

17/February/2005

CONTENTS

1. FUNCTIONS & FEATURES-----2

2. MECHANICAL SPECIFICATIONS-----2

3. BLOCK DIAGRAM-----2

4. EXTERNAL DIMENSIONS-----3

5. PIN ASSIGNMENT-----3

6.1 PCB DRAWING AND DESCRIPTION-----4

6.2 EXAMPLE APPLICATION-----5

6.3 THE MODULE NO. IS PRINTED ON THE PCB-----5

7. BACKLIGHT & SWITCH-----6

8. DISPLAY DATA RAM-----6

9. MAXIMUM ABSOLUTE LIMIT-----7

10. ELECTRICAL CHARACTERISTICS-----7

 10-1 DC CHARACTERISTICS-----7

 10-2 AC CHARACTERISTICS-----8

 10-2-1 WRITE MODE-----8

 10-2-2 READ MODE-----9

11. CONTROL AND DISPLAY COMMAND-----10

12. STANDARD CHARACTER PATTERN (S6A0069-Cyrillic)-----11

13. LCM INITIALIZING BY INSTRUCTION-----12

 13-1 8-BIT INTERFACE MODE-----12

 13-2 4-BIT INTERFACE MODE-----13

14. LCD MODULES HANDLING PRECAUTIONS-----14

15. OTHERS-----14

1.FUNCTIONS & FEATURES

●

MODULE	LCD TECHNOLOGY	POLARIZER	REMARKS
DEM 20231 SYH-PY-CYR22	STN Yellow/Green	Transflective Positive Mode	Cyrillic Character Font

- Viewing Direction : 6 o'clock
- Driving Scheme : 1/16 Duty Cycle, 1/5 Bias
- Power Supply Voltage : 5.0 Volt
- Backlight Color : Yellow Green (Lightguide)
- V_{LCD} Adjustable For Best Contrast : 4.5 Volt (typ.)
- Operation temperature :-20°C to +70°C
- Storage temperature :-25°C to +75°C
- Display Format : 20 x 2 Characters (5x8 dots, 208kinds)
- Internal Memory : CGROM (10,080 bits)
: CGRAM (64 x 8 bits)
: DDRAM (80 x 8 bits)
- Interface : Easy Interface with 4-bit or 8-bit MPU

2. MECHANICAL SPECIFICATIONS

- Character Pitch : 3.70 (W) x 5.95 (H) mm
- Character Size : 3.20 (W) x 5.55 (H) mm
- Character Font : 5 x 8 dots
- Dot Size : 0.60 (W) x 0.65 (H) mm
- Dot Pitch : 0.05 mm

3. BLOCK DIAGRAM

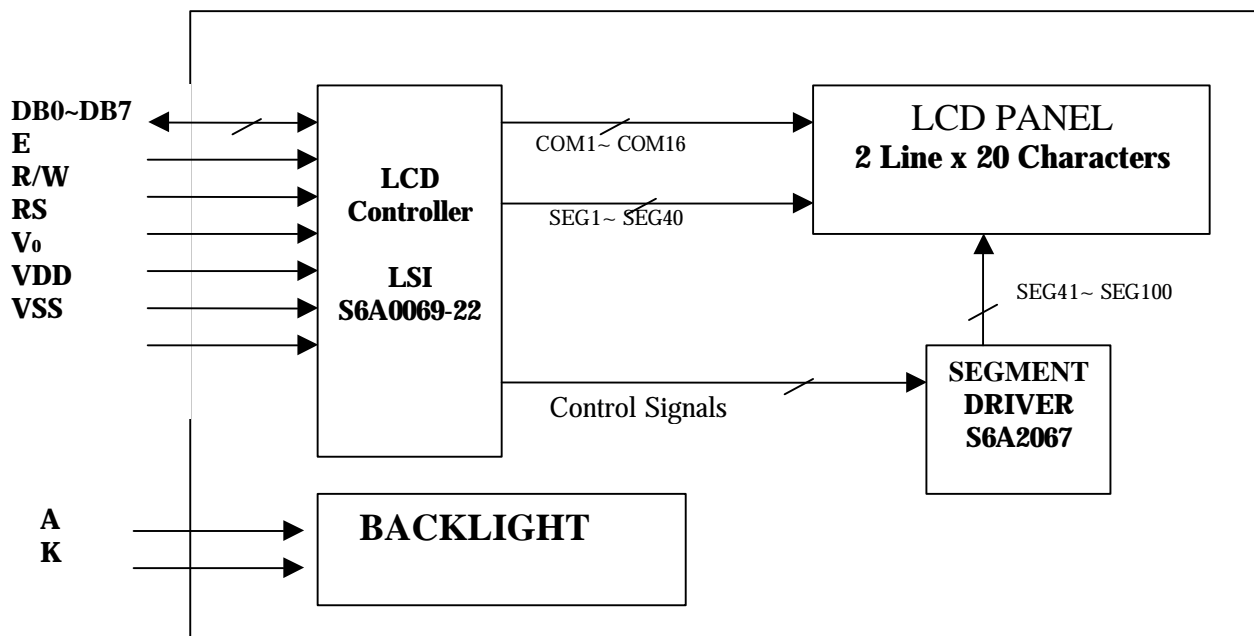

4. EXTERNAL DIMENSIONS

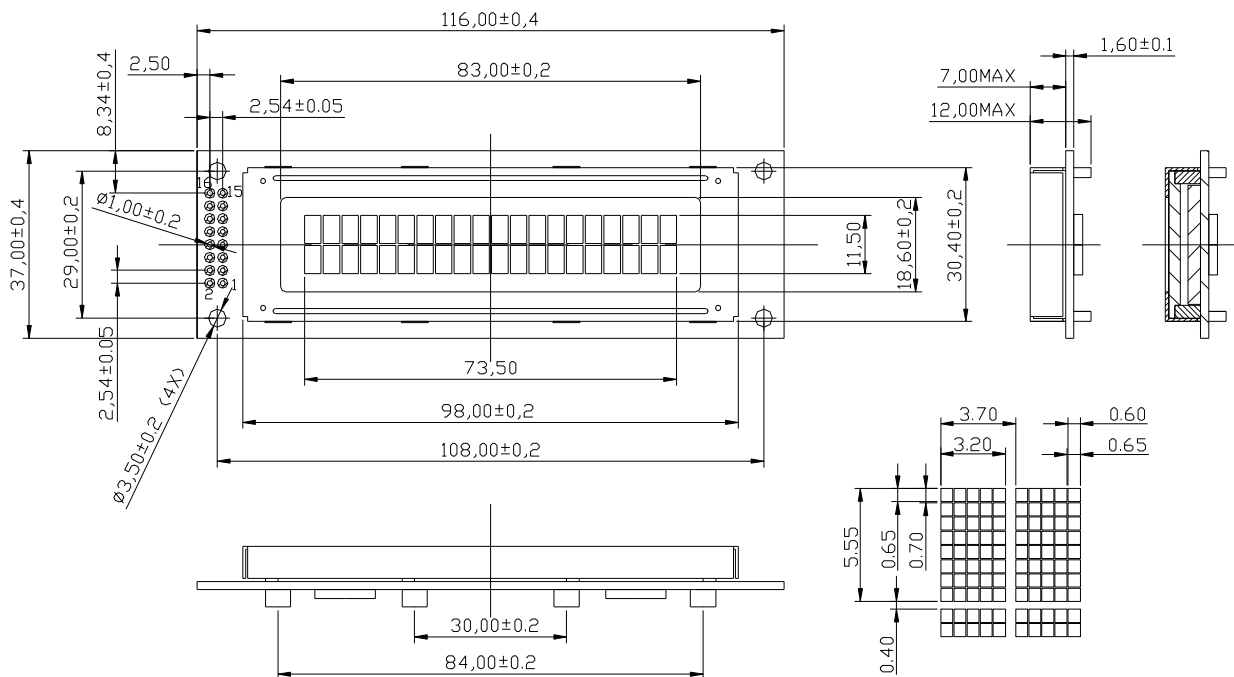

5. PIN ASSIGNMENT

Pin No.	Symbol	Function
1	V _{SS}	Ground terminal of module.
2	V _{DD}	Power terminal of module 2.7V to 5.5V.
3	V ₀	Power Supply for liquid crystal drive.
4	RS	Register select RS = 0 (Instruction register) RS = 1 (Data register)
5	R/W	Read /Write R/W = 1 (Read) R/W = 0 (Write)
6	E	Read/Write Enable Signal
7	DB0	Bi-directional data bus, data transfer is performed once, thru DB0 to DB7, in the case of interface data length is 8-bits; and twice, thru DB4 to DB7 in the case of interface data length is 4-bits. Upper four bits first then lower four bits.
8	DB1	
9	DB2	
10	DB3	
11	DB4	
12	DB5	
13	DB6	
14	DB7	
15	LED – (K)	Please also refer to 6.1 PCB drawing and description.
16	LED + (A)	Please also refer to 6.1 PCB drawing and description.

6.1 PCB DRAWING AND DESCRIPTION

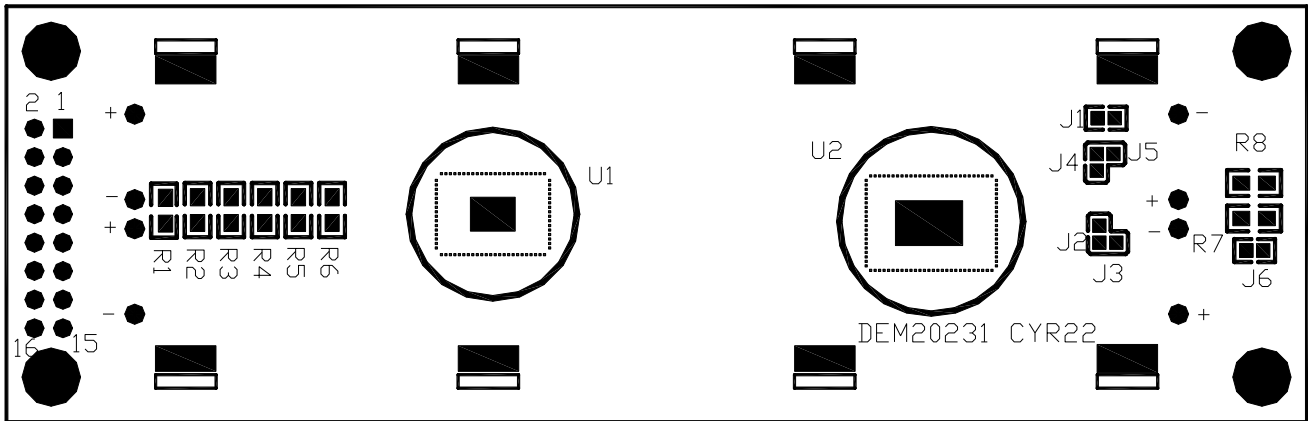

DESCRIPTION:

6-1-1.The polarity of the pin 15 and the pin 16

symbol	symbol state	J3,J5	J2,J4	LED Polarity	
				15 Pin	16 Pin
J2,J4	Each solder-bridge	Each open	Each closed	Anode	Cathode
J3,J5	Each solder-bridge	Each closed	Each open	Cathode	Anode

Note: in application module, J2= J4= open, J3= J5= closed

6-1-2.The metal-bezel is set on ground when the J1 is closed

Note: in application module, J1= closed

6-1-3.The LED resistor can be bridged when the J6 is closed

Note: in application module: J6= open

6-1-4.The R7 and the R8 are the LED resistor.

Note: in application module, R7= 12Ω, R8= open

6.2 Example application

6-2-1. The LED resistor should be bridged as following.

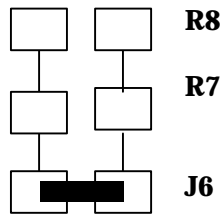

6-2-2. The 15 pin is the anode and the 16 pin is the cathode as following.



6-2-3. The 15 pin is the cathode and the 16 pin is the anode as following.



6-2-4. The metal-bezel is on ground as following.



6.3 The module number DEM 20231 is printed on the PCB.

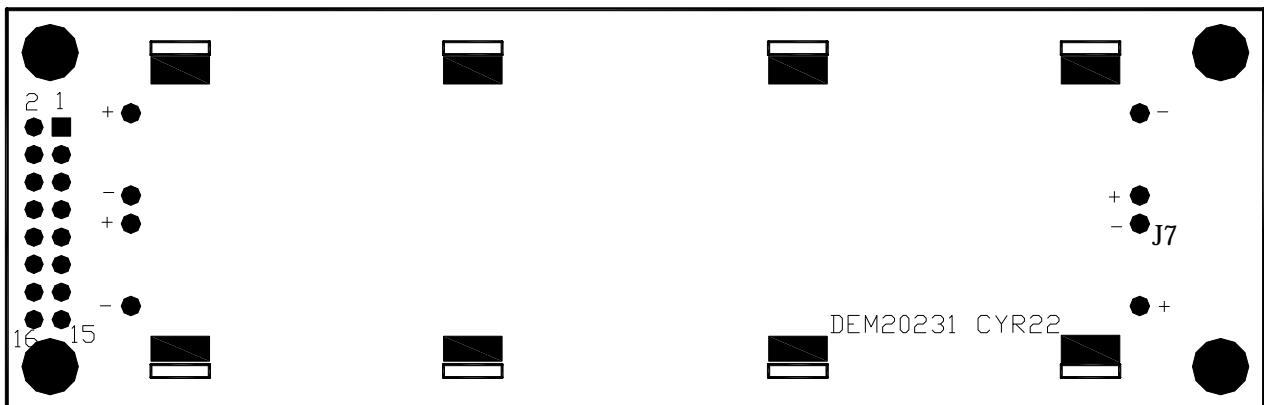

7. BACKLIGHT & SWITCH (Ta = -20 ~ +70°C)

Item	Symbol	Standard Value	Unit	Applicable Terminal
Backlight Voltage	V	4.2	V	A~K
Backlight Current	I	40	mA	

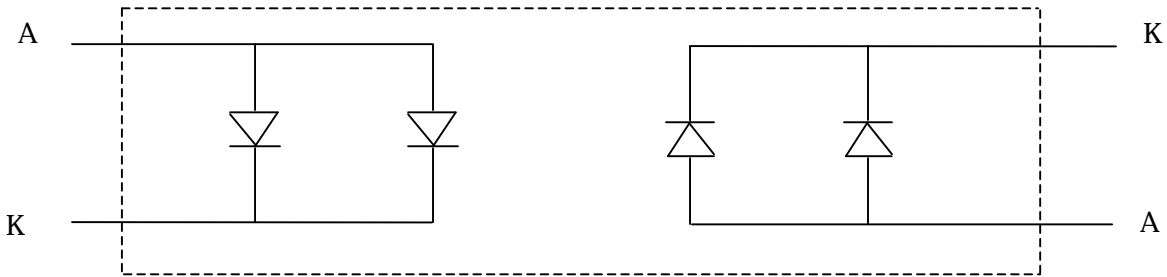

8. DISPLAY DATA RAM (DDRAM)

	1	2	...	10	11	12	13	14	15	16	17	18	19	20	← DISPLAY POSITION
FIRST LINE	00	01	...	09	0A	0B	0C	0D	0E	0F	10	11	12	13	← DDRAM ADDRESS
SECOND LINE	40	41	...	49	4A	4B	4C	4D	4E	4F	50	51	52	53	

9. MAXIMUM ABSOLUTE POWER RATINGS (Ta= 25°C)

Item	Symbol	Standard value	Unit
Power supply voltage (1)	V _{DD}	-0.3 ~ +7.0	V
Power supply voltage (2)	V ₀	V _{DD} -15.0 ~ V _{DD} +0.3	V
Input voltage	V _{IN}	-0.3 ~ V _{DD} +0.3	V
Volt. For BL	V _{LED1}	4 ~ 4.5	V
Operating temperature	T _{opr}	-20 ~ +70	°C
Storage temperature	T _{stg}	-25 ~ +75	°C

10. ELECTRICAL CHARACTERISTICS

10-1 DC Characteristics (V_{DD} = 4.5V ~ 5.5V, Ta = -20 ~ +70°C)

Item	Symbol	Standard Value			Test Condition	Unit
		MIN	TYP	MAX		
Operating Voltage	V _{DD}	4.5	5	5.5	-----	V
Supply Current	I _{DD1}	----	0.35	0.6	V _{DD} = 5V, f _{osc} = 270kHz	mA
Input Voltage (1) (except OSC1)	V _{IL1}	-0.3	--	0.6	-----	V
	V _{IH1}	2.2	--	V _{DD}	-----	
Input Voltage (2) (OSC1)	V _{IL2}	-0.2	--	1.0	-----	V
	V _{IH2}	V _{DD} -1.0	--	V _{DD}	-----	
Output Voltage (1) (DB0 to DB7)	V _{OL1}	---	----	0.4	I _{OL} = 1.2uA	V
	V _{OH1}	2.4	---	----	I _{OH} = -0.205mA	
Output Voltage (2) (except DB0 to DB7)	V _{OL2}	-----	---	0.1V _{DD}	I _{OL} = 40uA	V
	V _{OH2}	0.9V _{DD}	---	-----	I _{OH} = -40uA	
Voltage Drop	V _{dCOM}	-----	---	1	I _O = ± 0.1 mA	V
	V _{dSEG}	-----	---	1		
Input Leakage Current	I _{IKG}	-1	---	1	V _{IN} = 0 V to V _{DD}	uA
Input Low Current	I _{IL}	-50	-125	-250	V _{IN} = 0V, V _{DD} = 5V(pull up)	uA
Internal Clock (external Rf)	f _{OSC1}	190	270	350	Rf = 91k ± 2% (V _{DD} = 5V)	kHz
External Clock	f _{OSC}	125	270	410	----	kHz
	duty	45	50	55	----	%
	t _R , t _F	---	---	0.2	----	us
LCD Driving Voltage	V _{LCD}	3.0	4.5	13.0	V _{DD} -V ₅ (1/5 Bias)	V

10-2 AC Characteristics ($V_{DD} = 4.5V \sim 5.5V$, $T_a = -20 \sim +70^{\circ}C$)

10-2-1. Write mode (writing data from MPU to module)

Characteristic	Symbol	Min	Typ	Max	Unit	Test PIN
E Cycle Time	t_c	500			ns	E
E Rise Time	t_R			20	ns	E
E Fall Time	t_F			20	ns	E
E Pulse width (High, Low)	t_W	230			ns	E
R/W and RS Set-up Time	t_{SU1}	40			ns	R/W, RS
R/W and RS Hold Time	t_{H1}	10			ns	R/W, RS
Data Set-up Time	t_{SU2}	80			ns	DB0~DB7
Data Hold Time	t_{H2}	10			ns	DB0~DB7

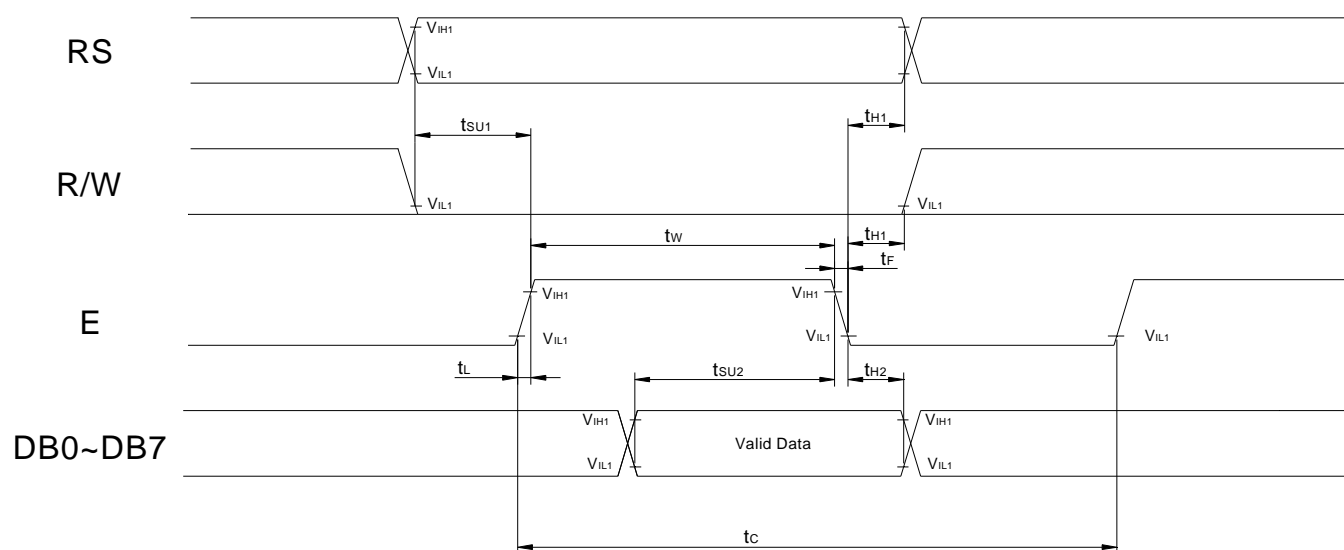

10-2-2.Read mode (Reading data from module to MPU)

Characteristic	Symbol	Min	Typ	Max	Unit	Test PIN
E Cycle Time	t_C	500			ns	E
E Rise Time	t_R			20	ns	E
E Fall Time	t_F			20	ns	E
E Pulse width (High, Low)	t_W	230			ns	E
R/W and RS Set-up Time	t_{SU}	40			ns	R/W, RS
R/W and RS Hold Time	t_H	10			ns	R/W, RS
Data output Delay Time	t_D			120	ns	DB0~DB7
Data Hold Time	t_{DH}	5			ns	DB0~DB7

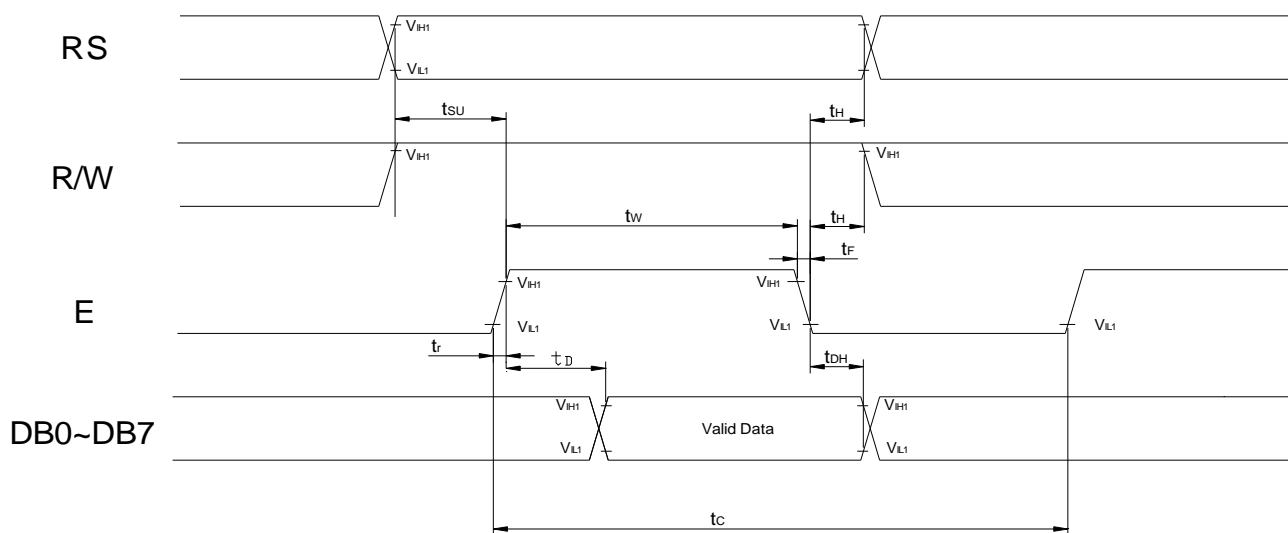

11. CONTROL AND DISPLAY COMMAND

Command	RS	R/W	DB7	DB6	DB5	DB4	DB3	DB2	DB1	DB0	Execution time (fosc=270KHz)	Remark															
Clear Display	L	L	L	L	L	L	L	L	L	H	1.53ms																
Return home	L	L	L	L	L	L	L	L	H	X	1.53ms	Cursor move to first digit															
Entry mode set	L	L	L	L	L	L	L	H	I/D	SH	39us	I/D: set cursor move direction <table border="1"> <tr> <td rowspan="2">I/D</td> <td>H</td> <td>Increase</td> </tr> <tr> <td>L</td> <td>Decrease</td> </tr> </table> SH: Specifies shift of display <table border="1"> <tr> <td rowspan="2">SH</td> <td>H</td> <td>Display is shifted</td> </tr> <tr> <td>L</td> <td>Display is not shifted</td> </tr> </table>	I/D	H	Increase	L	Decrease	SH	H	Display is shifted	L	Display is not shifted					
I/D	H	Increase																									
	L	Decrease																									
SH	H	Display is shifted																									
	L	Display is not shifted																									
Display on/off control	L	L	L	L	L	L	H	D	C	B	39us	Display <table border="1"> <tr> <td rowspan="2">D</td> <td>H</td> <td>Display on</td> </tr> <tr> <td>L</td> <td>Display off</td> </tr> </table> Cursor <table border="1"> <tr> <td rowspan="2">C</td> <td>H</td> <td>Cursor on</td> </tr> <tr> <td>L</td> <td>Cursor off</td> </tr> </table> Blinking <table border="1"> <tr> <td rowspan="2">B</td> <td>H</td> <td>Blinking on</td> </tr> <tr> <td>L</td> <td>Blinking off</td> </tr> </table>	D	H	Display on	L	Display off	C	H	Cursor on	L	Cursor off	B	H	Blinking on	L	Blinking off
D	H	Display on																									
	L	Display off																									
C	H	Cursor on																									
	L	Cursor off																									
B	H	Blinking on																									
	L	Blinking off																									
Cursor or Display Shift	L	L	L	L	L	H	S/C	R/L	---	---	39us	<table border="1"> <tr> <td rowspan="2">SC</td> <td>H</td> <td>Display shift</td> </tr> <tr> <td>L</td> <td>Cursor move</td> </tr> </table> <table border="1"> <tr> <td rowspan="2">R/L</td> <td>H</td> <td>Right shift</td> </tr> <tr> <td>L</td> <td>Left shift</td> </tr> </table>	SC	H	Display shift	L	Cursor move	R/L	H	Right shift	L	Left shift					
SC	H	Display shift																									
	L	Cursor move																									
R/L	H	Right shift																									
	L	Left shift																									
Function Set	L	L	L	L	H	DL	N	F	X-	X	39us	<table border="1"> <tr> <td rowspan="2">DL</td> <td>H</td> <td>8bits interface</td> </tr> <tr> <td>L</td> <td>4bits interface</td> </tr> </table> <table border="1"> <tr> <td rowspan="2">N</td> <td>H</td> <td>2 line display</td> </tr> <tr> <td>L</td> <td>1 line display</td> </tr> </table> <table border="1"> <tr> <td rowspan="2">F</td> <td>H</td> <td>Display on</td> </tr> <tr> <td>L</td> <td>Display off</td> </tr> </table>	DL	H	8bits interface	L	4bits interface	N	H	2 line display	L	1 line display	F	H	Display on	L	Display off
DL	H	8bits interface																									
	L	4bits interface																									
N	H	2 line display																									
	L	1 line display																									
F	H	Display on																									
	L	Display off																									
Set CGRAM address	L	L	L	H	AC5	AC4	AC3	AC2	AC1	AC0	39us	CGRAM data is sent and received after this setting															
Set DDRAM address	L	L	H	AC6	AC5	AC4	AC3	AC2	AC1	AC0	39us	DDRAM data is sent and received after this setting															
Read busy flag& address	L	H	BF	AC6	AC5	AC4	AC3	AC2	AC1	AC0	0us	<table border="1"> <tr> <td rowspan="2">BF</td> <td>H</td> <td>Busy</td> </tr> <tr> <td>L</td> <td>Ready</td> </tr> </table> -Reads BF indication internal operating is being performed -Reads address counter contents	BF	H	Busy	L	Ready										
BF	H	Busy																									
	L	Ready																									
Write data to RAM	H	L	D7	D6	D5	D4	D3	D2	D1	D0	43us	Write data into DDRAM or CGRAM															
Read data from RAM	H	H	D7	D6	D5	D4	D3	D2	D1	D0	43us	Read data from DDRAM or CGRAM															

12. STANDARD CHARACTER PATTERN (S6A0069-Cyrillic)

Uppa(4bit) Lowa(4bit)		LLLL	LLLH	LLHL	LLHH	LHLL	LHLH	LHHL	LH HH	HLLL	HLLH	HLHL	HLHH	HLLL	HHLH	HHHL	HHHH
LLLL	CG RAM (1)																
LLLH	(2)																
LLHL	(3)																
LLHH	(4)																
LHLL	(5)																
LHLH	(6)																
LHHL	(7)																
LH HH	(8)																
HLLL	(1)																
HLLH	(2)																
HLHL	(3)																
HLHH	(4)																
HLLL	(5)																
HHLH	(6)																
HHHL	(7)																
HHHH	(8)																

13. LCM INITIALIZING BY INSTRUCTION

13-1. 8-bit interface mode

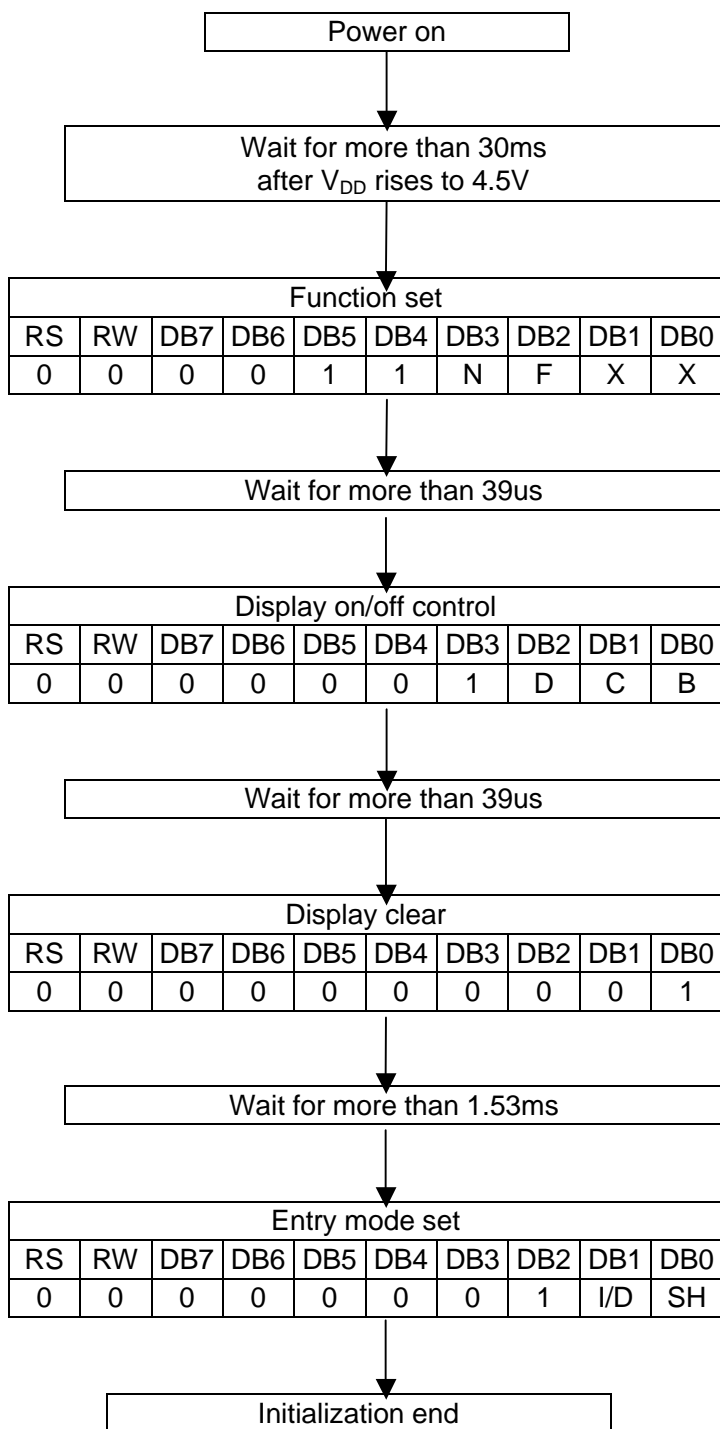

Condition: fosc=270khz

N	0	1-line mode
	1	2-line mode

F	0	5 x 7 dots
	1	5 x 10 dots

D	0	display off
	1	display on

C	0	cursor off
	1	cursor on

B	0	blink off
	1	blink on

I/D	0	decrement mode
	1	increment mode

SH	0	entire shift off
	1	entire shift on

13-2. 4-bit interface mode

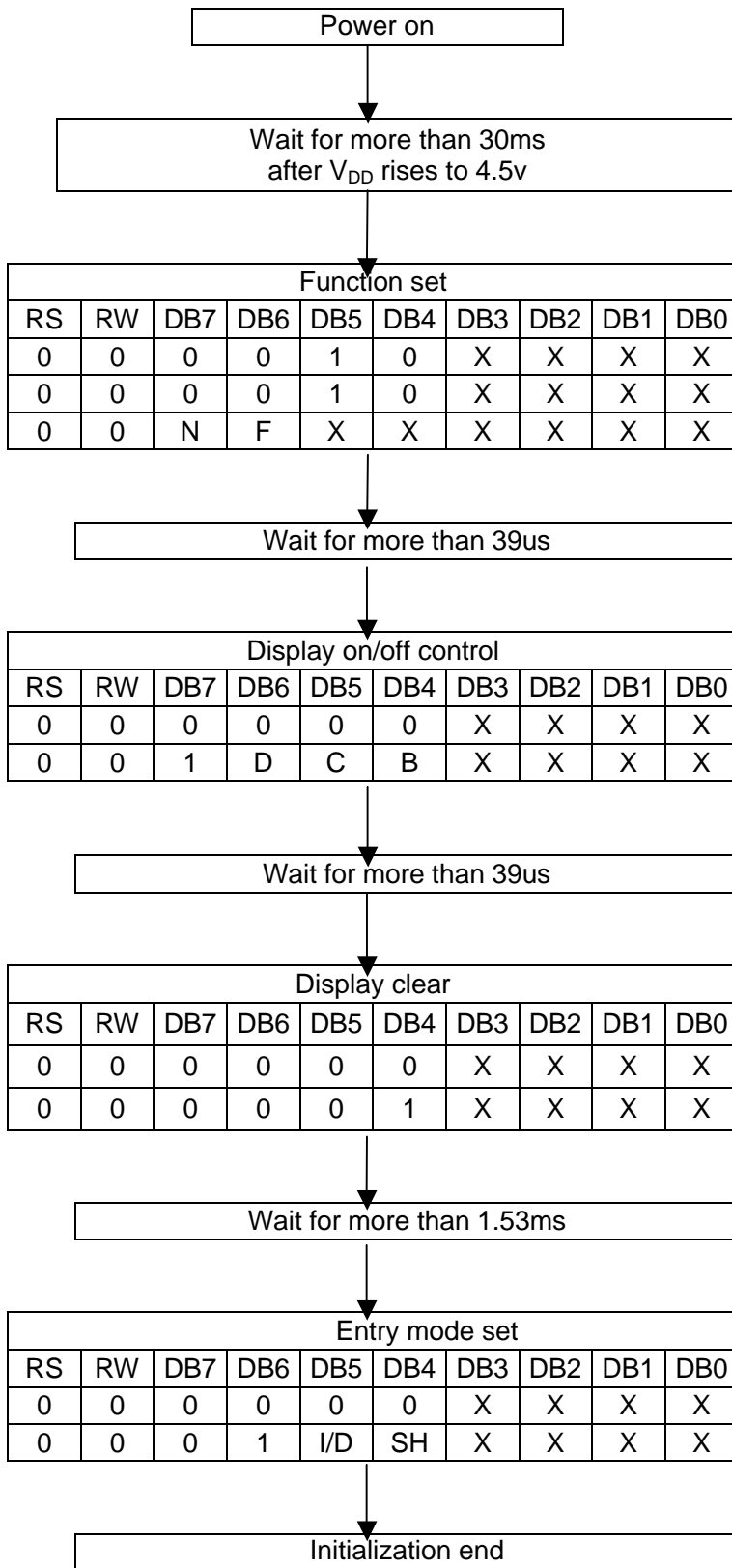

Condition: fosc=270khz

N	0	1-line mode
	1	2-line mode
F	0	5x7 dots
	1	5x10 dots

D	0	display off
	1	display on
C	0	cursor off
	1	cursor on
B	0	blink off
	1	blink on

I/D	0	decrement mode
	1	increment mode
SH	0	entire shift off
	1	entire shift on

14. LCD Modules Handling Precautions

- Please remove the protection foil of polarizer before using.
- The display panel is made of glass. Do not subject it to a mechanical shock by dropping it from a high place, etc.
- If the display panel is damaged and the liquid crystal substance inside it leaks out, do not get any in your mouth. If the substance come into contact with your skin or clothes promptly wash it off using soap and water.
- Do not apply excessive force to the display surface or the adjoining areas since this may cause the color tone to vary.
- The polarizer covering the display surface of the LCD module is soft and easily scratched. Handle this polarize carefully.
- To prevent destruction of the elements by static electricity, be careful to maintain an optimum work environment.
 - Be sure to ground the body when handling the LCD module.
 - Tools required for assembly, such as soldering irons, must be properly grounded.
 - To reduce the amount of static electricity generated, do not conduct assembly and other work under dry conditions.
 - The LCD module is coated with a film to protect the display surface. Exercise care when peeling off this protective film since static electricity may be generated.
- Storage precautions
When storing the LCD modules, avoid exposure to direct sunlight or to the light of fluorescent lamps. Keep the modules in bags designed to prevent static electricity charging under low temperature / normal humidity conditions (avoid high temperature / high humidity and low temperatures below 0°C). Whenever possible, the LCD modules should be stored in the same conditions in which they were shipped from our company.

15. Others

- Liquid crystals solidify at low temperature (below the storage temperature range) leading to defective orientation of liquid crystal or the generation of air bubbles (black or white). Air bubbles may also be generated if the module is subjected to a strong shock at a low temperature.
- If the LCD modules have been operating for a long time showing the same display patterns may remain on the screen as ghost images and a slight contrast irregularity may also appear. Abnormal operating status can be resumed to be normal condition by suspending use for some time. It should be noted that this phenomena does not adversely affect performance reliability.
- To minimize the performance degradation of the LCD modules resulting from caused by static electricity, etc. exercise care to avoid holding the following sections when handling the modules:
 - Exposed area of the printed circuit board
 - Terminal electrode sections