

Display Elektronik GmbH

DATA SHEET

LCD MODULE

**DEM 20485 SY &
DEM 20485 SYH**

Product specification

Version : 1

17-May-03

GENERAL SPECIFICATION

COB MODULE NO. :

DEM 20485 SY & DEM 20485 SYH

CUSTOMER P / N

VERSION NO.	CHANGE DESCRIPTION	DATE
0	ORIGINAL VERSION	20003/05/08
1	CHANGE EXTERNAL DIMENSIONS	2003/05/17

PREPARED BY: CHEN SHI WEN

DATE: 17.05.2003

APPROVED BY: LIU XING

DATE: 17.05.2003

CONTENTS

1. FUNCTIONS & FEATURES -----	2
2. MECHANICAL SPECIFICATIONS -----	2
3. BLOCK DIAGRAM -----	2
4. EXTERNAL DIMENSIONS -----	3
5. PIN ASSIGNMENT -----	3
6.1 PCB DRAWING AND DESCRIPTION-----	4
6.2 THE MODULE NO. IS PRINTED ON THE PCB .-----	5
7. DISPLAY DATA RAM (DRAM)-----	5
8. MAXIMUM ABSOLUTE POWER RATINGS-----	6
9. ELECTRICAL CHARACTERISTICS -----	6
9-1 DC CHARACTERISTICS-----	6
9-2 AC CHARACTERISTICS-----	7
9-2-1 WRITE MODE-----	7
9-2-2 READ MODE-----	8
10.CONTROL AND DISPLAY COMMAND-----	9
11.STANDARD CHARACTER PATTERN -----	10
12.LCM INITIALIZING BY INSTRUCTION-----	11
12-1 8 bit INTERFACE MODE-----	11
12-2 4 bit INTERFACE MODE-----	12
13. LCD MODULES HANDLING PRECAUTIONS-----	13
14. OTHERS -----	14

1. FUNCTIONS & FEATURES

- DEM 20485-Series LCD type:

MODULE	LCD MODEL	op. Temperature
DEM 20485 SY	STN Yellow/Green	0°C ... +50°C
DEM 20485 SYH	STN Yellow/Green	-20°C ... +70°C

- Viewing Direction : 6 O'clock
- Driving Scheme : 1/16 Duty Cycle, 1/5 Bias
- Power Supply Voltage : 2.7V ...5.5V (typ. 5.0V)
- Vlcd Adjustable for Best Contrast : 4.5V (typ.)
- Backlight : No backlight (reflective mode)
- Display Format : 4 x20 Characters
- Internal Memory : CGROM (10,080 bits)
: CGRAM (64 x 8 bits)
: DDRAM (80 x 8 bits for Digits)
- Interface : Easy Interface with a 4 - bit or 8 - bit MPU

2. MECHANICAL SPECIFICATIONS

- Character Pitch : 3.55(w) x 5.35(h) mm
- Character Size : 2.95(w) x 4.75(h) mm
- Character Font : 5 x 8 dots
- Dot Size : 0.55(w) x 0.55(h) mm
- Dot Gap : 0.05 mm

3. BLOCK Diagram

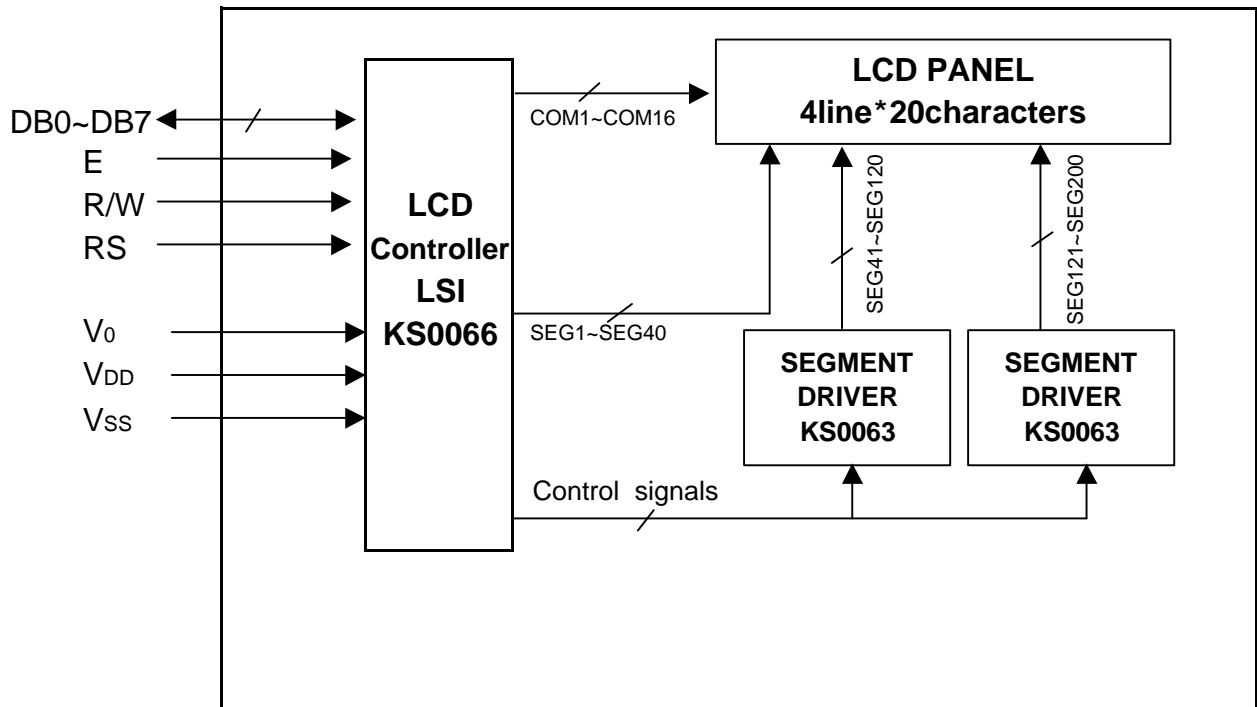

Figure 1.0

4. External Dimensions

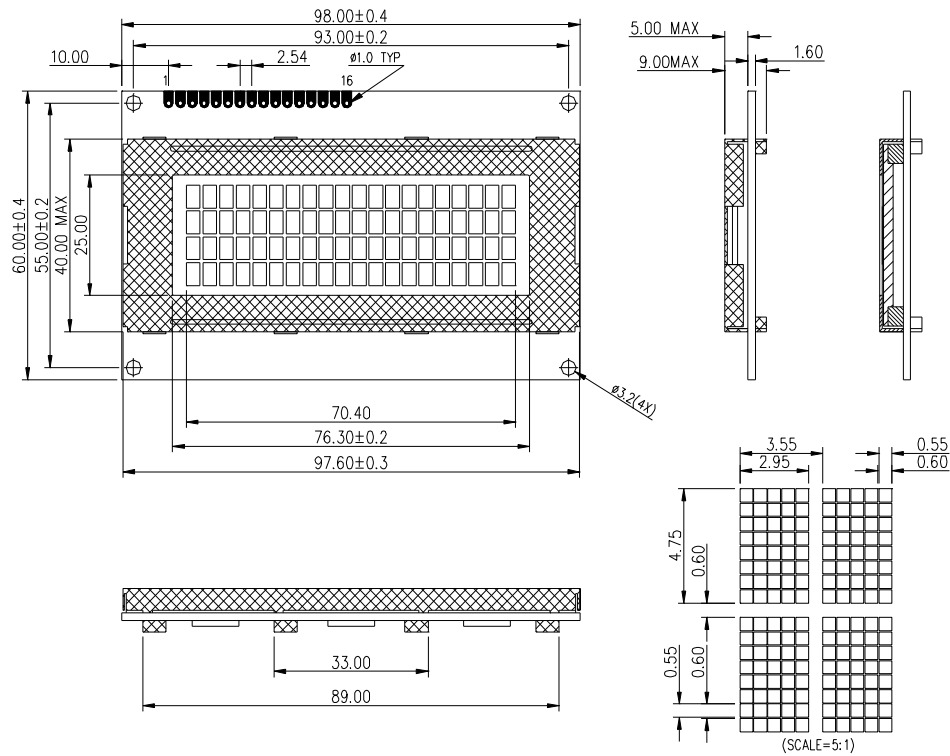

Figure 2.0

5. PIN Assignment

Pin No.	Symbol	Function
1	V _{SS}	Ground terminal of module
2	V _{DD}	Supply terminal of module +5 V
3	V ₀	Power Supply for Liquid crystal Drive
4	RS	Register Select RS = 0 (Instruction Register) RS = 1(Data Register)
5	R/W	Read / Write R/W = 1(Read) R/W = 0(Write)
6	E	Enable
7	DB0	Bi-directional Data Bus, Data Transfer is performed once , thru DB0~DB7 , in the case of interface data . Length is 8-bits; and twice , thru DB4~DB7 in the case of interface data length is 4-bits . Upper four bits first then lower four bits .
8	DB1	
9	DB2	
10	DB3	
11	DB4	
12	DB5	
13	DB6	
14	DB7	
15	LED - (K)	Not Used for this version without LEE
16	LED + (A)	

6.1 PCB DRAWING AND DESCRIPTION

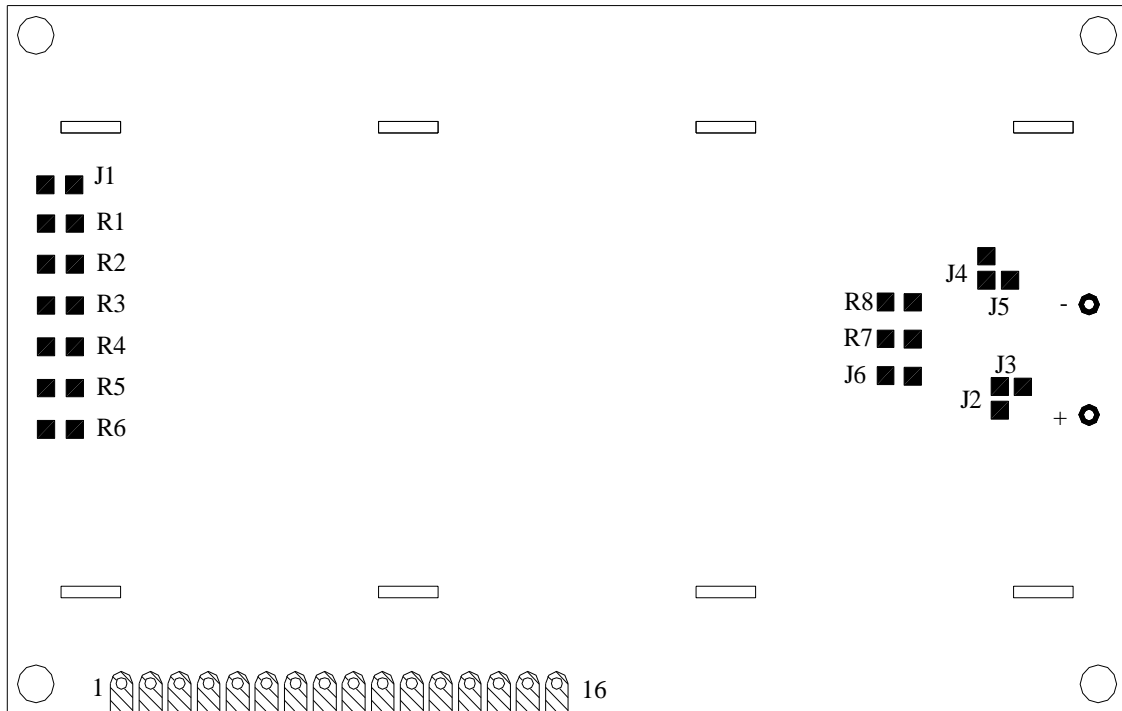

Figure 3.0

Description :

6-1-1. The polarity of the pin 15 and the pin 16 , but it is not used in here .

Symbol	State	Symbol		LED Polarity	
		J3,J5	J2,J4	15 Pin	16 Pin
J2,J4	Each Solder- Bridge	Each Open	————	Anode	Cathode
J3,J5	Each Solder- Bridge	————	Each Open	Cathode	Anode

6-1-2. The metal-bezel should be on ground when the J1 is Solder- Bridge .

6-1-3. The LED Resistor should be bridged when the J6 is Solder-Bridge ,but it is not used in here

6-1-4. The R7 and R8 are the LED Resistor, but it is not used in here .

6-1-5 The metal-bezel is on ground as following. (J1=CLOSED)



6.2 The module No. is printed on the PCB .

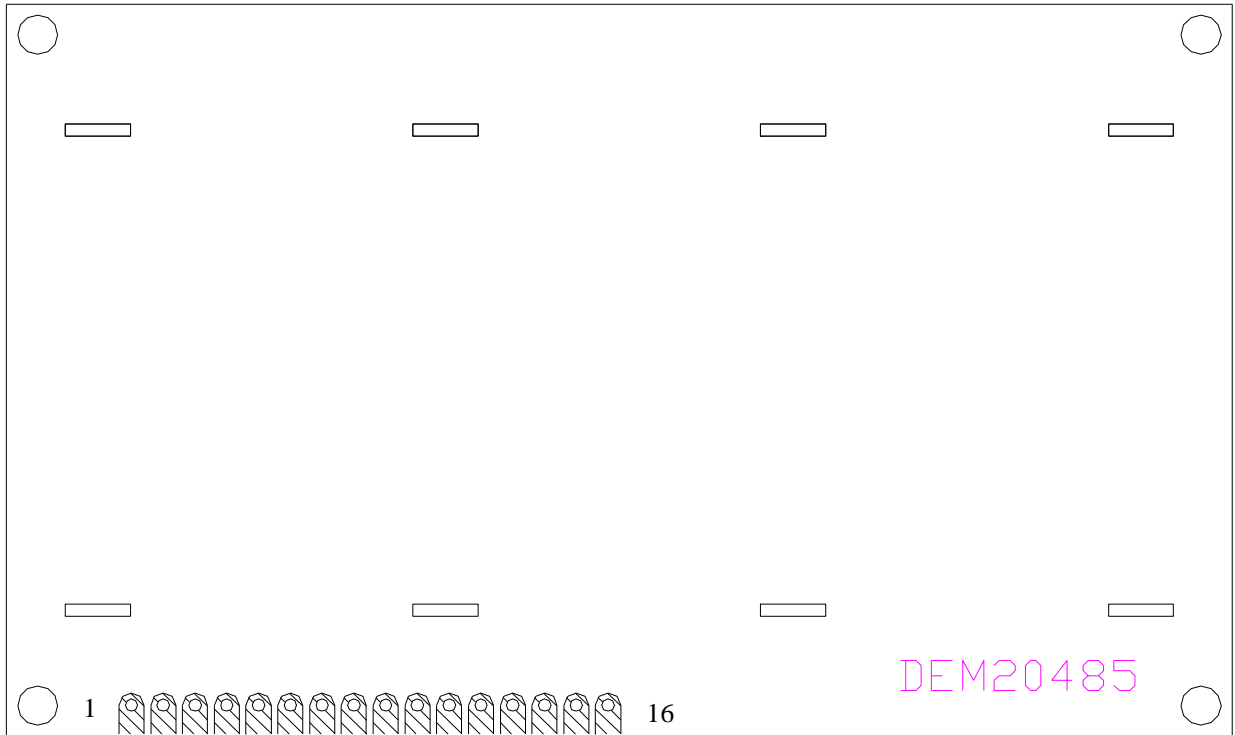

Figure 4.0

7. DISPLAY DATA RAM (DDRAM)

	1	2	3	4	5	6	7	8	9	10	11	12	13	14	15	16	17	18	19	20
FIRST LINE	00	01	02	03	04	05	06	07	08	09	0A	0B	0C	0D	0E	0F	10	11	12	13
SECOND LINE	40	41	42	43	44	45	46	47	48	49	4A	4B	4C	4D	4E	4F	50	51	52	53
THIRD LINE	14	15	16	17	18	19	1A	1B	1C	1D	1E	1F	20	21	22	23	24	25	26	27
FOURTH LINE	54	55	56	57	58	59	5A	5B	5C	5D	5E	5F	60	61	62	63	64	65	66	67

DISPLAY POSITION ←

←

DD RAM ADDRESS ←

8. MAXIMUM ABSOLUTE POWER RATINGS (Ta = 25°C)

Item	Symbol	Standard value	Unit
Power supply voltage(1)	V _{DD}	-0.3 ~ +7.0	V
Power supply voltage(2)	V ₀	V _{DD} -15.0 ~ V _{DD} +0.3	V
Input voltage	V _{IN}	-0.3 ~ V _{DD} +0.3	V
Operating temperature	T _{opr}	-20 ~ +70	°C
Storage temperature	T _{stg}	-30 ~ +80	°C

9. Electrical Characteristics

9-1. DC Characteristics (VDD = 4.5V ~ 5.5V, Ta = -20 ~ +70°C)

Item	Symbol	Standard Value			Test Condition	Unit
		MIN	TYP	MAX		
Operating Voltage	V _{DD}	4,5	5	5,5	—	V
Supply Current	I _{DD}	—	0,35	0,6	V _{DD} =5V, f _{osc} =270kHz	mA
Input Voltage(1) (except OSC1)	V _{IL1}	-0,3	—	0,6	—	V
	V _{IH1}	2,2	—	V _{DD}	—	
Input Voltage(2) (OSC1)	V _{IL2}	-0,2	—	1.0	—	V
	V _{IH2}	V _{DD} -1.0	—	V _{DD}	—	
Output Voltage (1) (DB0 TO DB7)	V _{OL1}	—	—	0,4	I _{OL} =1.2mA	V
	V _{OH1}	2,4	—	—	I _{OH} =-0.205mA	
Output Voltage (2) (except DB0 TO DB7)	V _{OL2}	—	—	0.1V _{DD}	I _{OL} =40uA	V
	V _{OH2}	0.9V _{DD}	—	—	I _{OH} =-40uA	
Voltage Drop	V _{dCOM}	—	—	1	I _O =0.1±mA	V
	V _{dSEG}	—	—	1		
Input Leakage Current	I _{IKG}	-1	—	1	V _{IN} =0 V to V _{DD}	uA
Input Low Current	I _{IL}	-50	-125	-250	V _{IN} =0V, V _{DD} =5V(pull up)	uA
Internal Clock (external Rf)	f _{OSC1}	190	270	350	Rf = 91k ± 2% (V _{DD} =5V)	kHz
	f _{OSC}	125	270	410	—	
External Clock	duty	45	50	55	—	%
	t _R , t _F	—	—	0,2	—	us
LCD Driving Voltage	V _{LCD}	3.0	—	13.0	V _{DD} -V ₅ (1/5, 1/4 Bias)	V

9-2 AC Characteristics ($V_{DD} = 4.5V \sim 5.5V$, $T_a = -20 \sim +70^{\circ}C$)

9-2-1. Write mode (writing data from MPU to DEM 20485-Series)

Characteristic	Symbol	Min	Typ	Max	Unit	Test PIN
E Cycle Time	t_C	500	—	—	ns	E
E Rise Time	t_R	—	—	20	ns	E
E Fall Time	t_F	—	—	20	ns	E
E Pulse width (High,Low)	t_W	230	—	—	ns	E
R/W and RS Set-up Time	t_{SU1}	40	—	—	ns	R/W,RS
R/W and RS Hold Time	t_{H1}	10	—	—	ns	R/W,RS
Data Set-up Time	t_{SU2}	80	—	—	ns	DB0~DB7
Data Hold Time	t_{H2}	10	—	—	ns	DB0~DB7

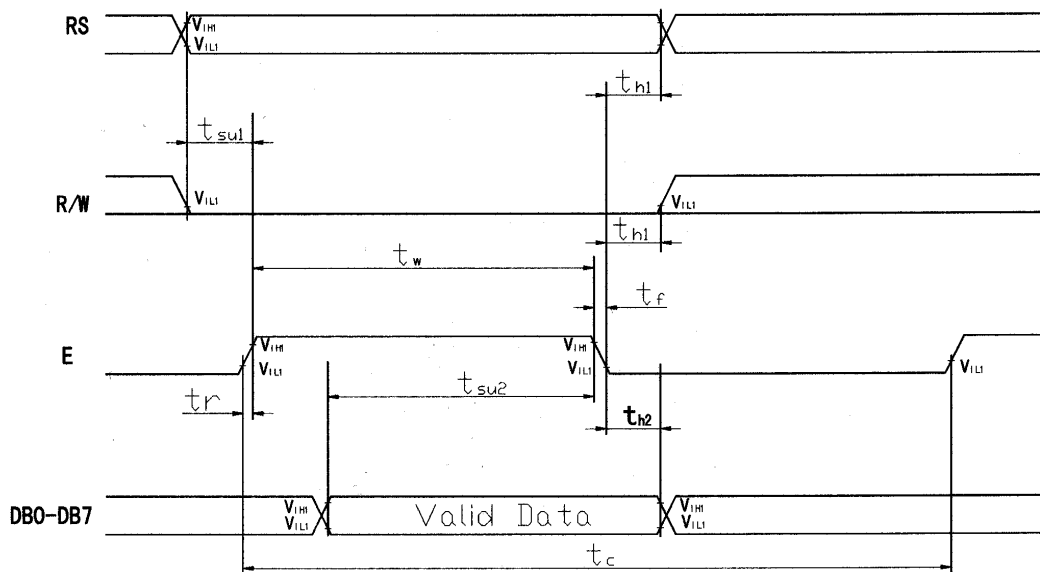

Figure 6.0

9-2-2.Read mode (Reading data from DEM 20485-Series to MPU)

Characteristic	Symbol	Min	Typ	Max	Unit	Test PIN
E Cycle Time	t_c	500	—	—	ns	E
E Rise Time	t_R	—	—	20	ns	E
E Fall Time	t_F	—	—	20	ns	E
E Pulse width (High , Low)	t_w	230	—	—	ns	E
R/W and RS Set-up Time	t_{SU}	40	—	—	ns	R/W,RS
R/W and RS Hold Time	t_H	10	—	—	ns	R/W,RS
Data output Delay Time	t_D	—	—	120	ns	DB0~DB7
Data Hold Time	t_{DH}	5	—	—	ns	DB0~DB7

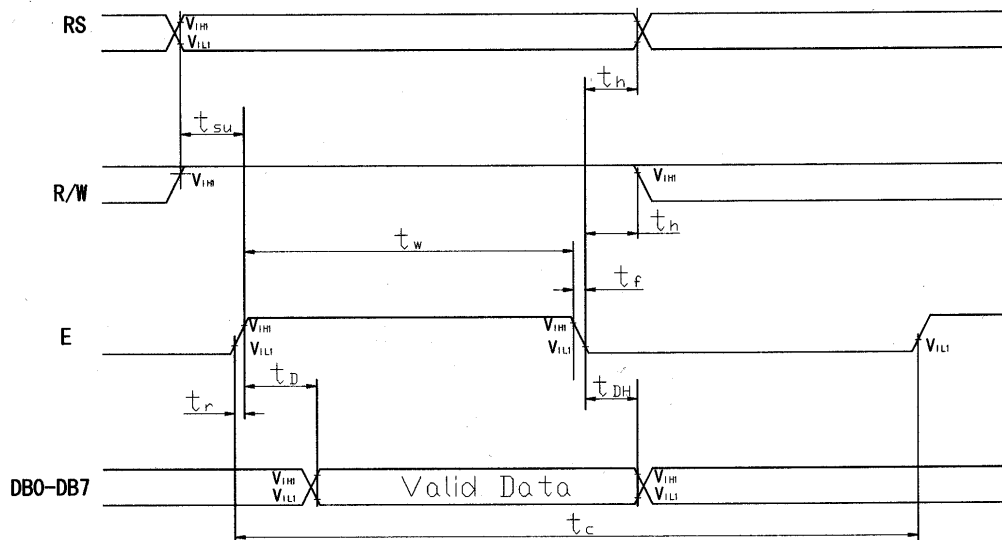

Figure7.0

10. CONTROL AND DISPLAY COMMAND

Command	RS	R/W	DB7	DB6	DB5	DB4	DB3	DB2	DB1	DB0	Execution time (fosc=270KHz)	Remark																		
clear Display	L	L	L	L	L	L	L	L	L	H	1.53ms																			
Return home	L	L	L	L	L	L	L	L	H	X	1.53ms	Cursor move to first digit																		
Entry mode set	L	L	L	L	L	L	L	H	I/D	SH	39us	I/D:set cursor move direction <table border="1"> <tr> <td>I/D</td> <td>H</td> <td>Increase</td> </tr> <tr> <td></td> <td>L</td> <td>Decrease</td> </tr> </table> SH:Specifies shift of display SH <table border="1"> <tr> <td></td> <td>H</td> <td>Display is shifted</td> </tr> <tr> <td></td> <td>L</td> <td>Display is not shifted</td> </tr> </table>	I/D	H	Increase		L	Decrease		H	Display is shifted		L	Display is not shifted						
I/D	H	Increase																												
	L	Decrease																												
	H	Display is shifted																												
	L	Display is not shifted																												
Display on/off control	L	L	L	L	L	L	H	D	C	B	39us	Display <table border="1"> <tr> <td>D</td> <td>H</td> <td>Display on</td> </tr> <tr> <td></td> <td>L</td> <td>Display off</td> </tr> </table> Cursor <table border="1"> <tr> <td>C</td> <td>H</td> <td>Cursor on</td> </tr> <tr> <td></td> <td>L</td> <td>Cursor off</td> </tr> </table> Blinking <table border="1"> <tr> <td>B</td> <td>H</td> <td>Blinking on</td> </tr> <tr> <td></td> <td>L</td> <td>Blinking off</td> </tr> </table>	D	H	Display on		L	Display off	C	H	Cursor on		L	Cursor off	B	H	Blinking on		L	Blinking off
D	H	Display on																												
	L	Display off																												
C	H	Cursor on																												
	L	Cursor off																												
B	H	Blinking on																												
	L	Blinking off																												
Cursor or Display Shift	L	L	L	L	L	H	S/C	R/L	X	X	39us	<table border="1"> <tr> <td>SC</td> <td>H</td> <td>Display shift</td> </tr> <tr> <td></td> <td>L</td> <td>Cursor move</td> </tr> </table> <table border="1"> <tr> <td>R/L</td> <td>H</td> <td>Right shift</td> </tr> <tr> <td></td> <td>L</td> <td>Left shift</td> </tr> </table>	SC	H	Display shift		L	Cursor move	R/L	H	Right shift		L	Left shift						
SC	H	Display shift																												
	L	Cursor move																												
R/L	H	Right shift																												
	L	Left shift																												
function Set	L	L	L	L	H	DL	N	F	X	X	39us	<table border="1"> <tr> <td>DL</td> <td>H</td> <td>3bits interface</td> </tr> <tr> <td></td> <td>L</td> <td>4bits interface</td> </tr> </table> <table border="1"> <tr> <td>N</td> <td>H</td> <td>2 line display</td> </tr> <tr> <td></td> <td>L</td> <td>1 line display</td> </tr> </table> <table border="1"> <tr> <td>F</td> <td>H</td> <td>Display on</td> </tr> <tr> <td></td> <td>L</td> <td>Display off</td> </tr> </table>	DL	H	3bits interface		L	4bits interface	N	H	2 line display		L	1 line display	F	H	Display on		L	Display off
DL	H	3bits interface																												
	L	4bits interface																												
N	H	2 line display																												
	L	1 line display																												
F	H	Display on																												
	L	Display off																												
Set CGRAM address	L	L	L	H	AC5	AC4	AC3	AC2	AC1	AC0	39us	CGRAM data is sent and received after this setting																		
Set DDRAM address	L	L	H	AC6	AC5	AC4	AC3	AC2	AC1	AC0	39us	DDRAM data is sent and received after this setting																		
Read busy flag& address	L	H	BF	AC6	AC5	AC4	AC3	AC2	AC1	AC0	0us	<table border="1"> <tr> <td>BF</td> <td>H</td> <td>Busy</td> </tr> <tr> <td></td> <td>L</td> <td>Ready</td> </tr> </table> -Reads BF indication internal operating is being performed -Reads address counter contents	BF	H	Busy		L	Ready												
BF	H	Busy																												
	L	Ready																												
Write data to RAM	H	L	D7	D6	D5	D4	D3	D2	D1	D0	43us	Write data into DDRAM or CGRAM																		
Read data from RAM	H	H	D7	D6	D5	D4	D3	D2	D1	D0	43us	Read data from DDRAM or CGRAM																		

*X:Don't care

11. STANDARD CHARACTER PATTERN

Upper(4bit) Lower(4bit)	LLLL	LLLH	LLHL	LLHH	LHLL	LHLH	LHHL	LHHH	HLLL	HLLH	HLHL	HLHH	HHLL	HHLH	HHHL	HHHH
LLLL	CG RAM (1)															
LLLH	(2)															
LLHL	(3)															
LLHH	(4)															
LHLL	(5)															
LHLH	(6)															
LHHL	(7)															
LHHH	(8)															
HLLL	(1)															
HLLH	(2)															
HLHL	(3)															
HLHH	(4)															
HHLL	(5)															
HHLH	(6)															
HHHL	(7)															
HHHH	(8)															

12. LCM INITIALIZING BY INSTRUCTION

12-1 8-bit interface mode

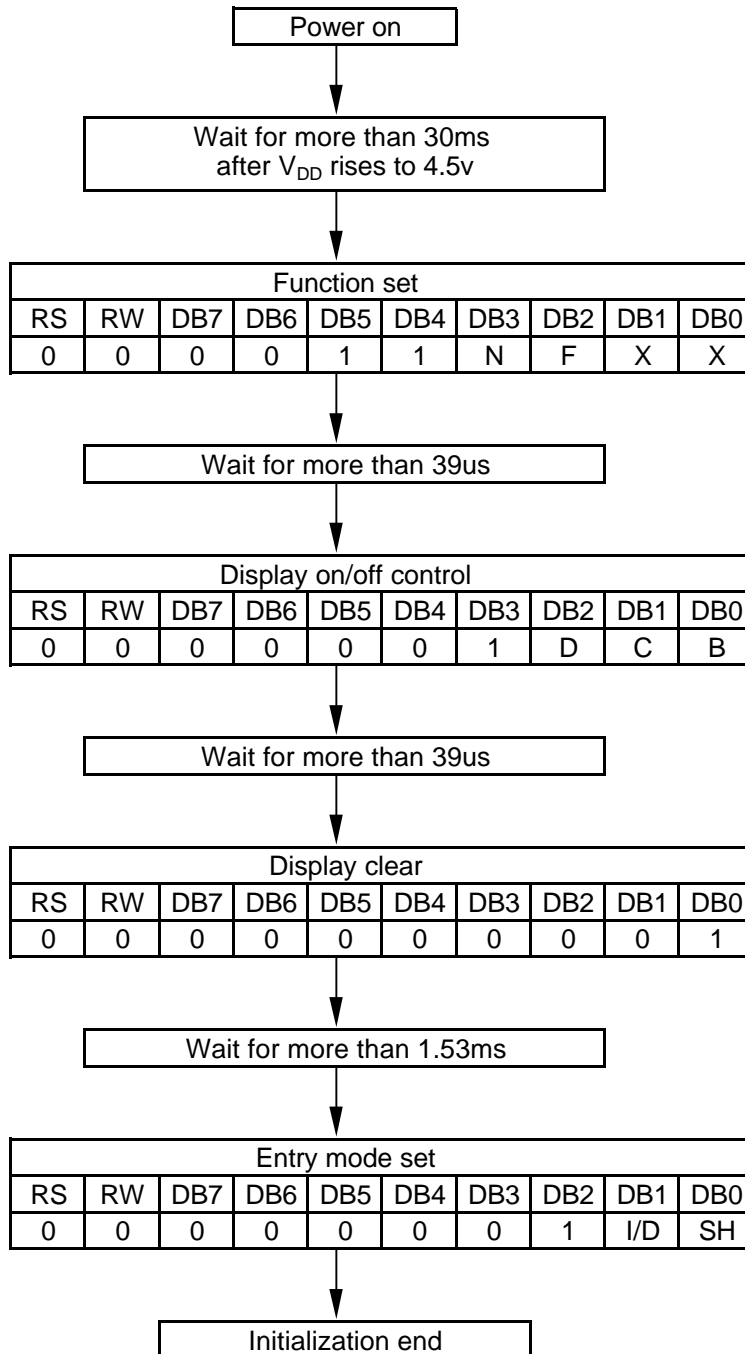

Condition : fosc=270khz

N	0	1-line mode
	1	2-line mode

F	0	display off
	1	display on

D	0	display off
	1	display on

C	0	cursor off
	1	cursor on

B	0	blink off
	1	blink on

I/D	0	decrement mode
	1	increment mode

SH	0	entire shift off
	1	entire shift on

12 -2 4-bit interface mode

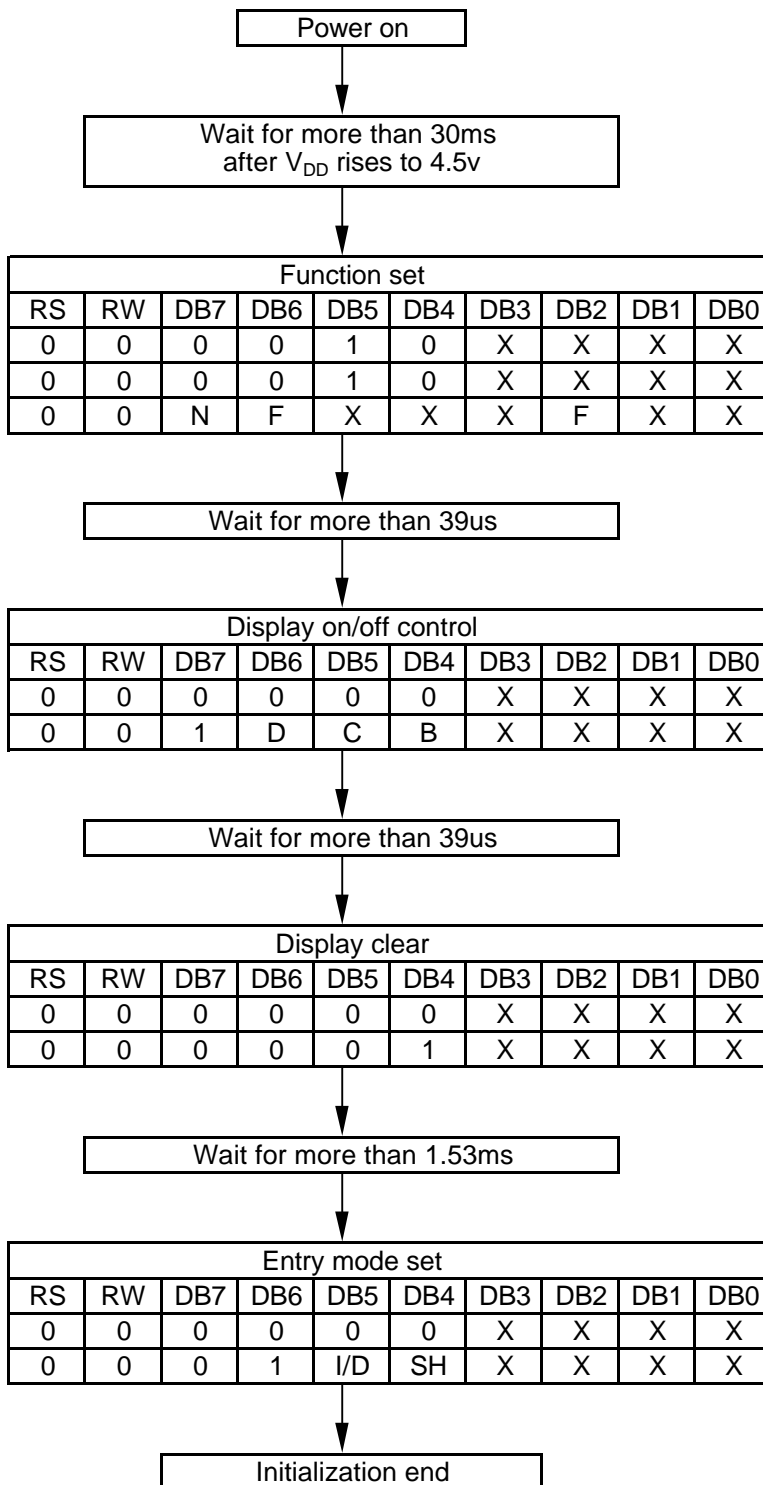

Condition : fosc=270khz

N	0	1-line mode
	1	2-line mode

F	0	display off
	1	display on

D	0	display off
	1	display on

C	0	cursor off
	1	cursor on

B	0	blink off
	1	blink on

I/D	0	decrement mode
	1	increment mode

SH	0	entire shift off
	1	entire shift on

13. LCD Modules Handling precautions

- The display panel is made of glass. Do not subject it to a mechanical shock by dropping it from a high place ,etc.
- If the display panel is damaged and the liquid crystal substance inside it leaks out , do not get any in your mouth . If the substance come into contact with your skin or clothes promptly wash it off using soap and water.

- Do not apply excessive force to the display surface or the adjoining areas since this may cause the color tone to vary.

- The polarizer covering the display surface of the LCD module is soft and easily scratched. handle this polarize carefully

- To prevent destruction of the elements by static electricity , be careful to maintain an optimum work environment.
 - Be sure to ground the body when handling the LCD Modules.
 - Tools required for assembly, such as soldering irons, must be properly grounded.
 - To reduce the amount of static electricity generated, do not conduct assembly and other work under dry conditions.
 - The LCD Module is coated with a film to protect the display surface. Exercise care when peeling off this protective film since static electricity may be generated.

- Storage Precautions
When storing the LCD Modules, avoid exposure to direct sunlight or to the light of fluorescent lamps. Keep the modules in bags designed to prevent static electricity charging under low temperature / normal humidity conditions (avoid high temperature / high humidity and low temperatures below 0°C).Whenever possible, the LCD Modules should be stored in the same conditions in which they were shipped from our company.

14. Others

- Liquid crystals solidify at low temperature (below the storage temperature range) leading to defective orientation of liquid crystal or the generation of air bubbles (black or white). Air bubbles may also be generated if the module is subjected to a strong shock at a low temperature.

- If the LCD Modules have been operating for a long time showing the same display patterns the display patterns may remain on the screen as ghost images and a slight contrast irregularity may also appear. Abnormal operating status can be resumed to be normal condition by suspending use for some time.
It should be noted that this phenomena does not adversely affect performance reliability.

- To minimize the performance degradation of the LCD Modules resulting from caused by static electricity , etc . Exercise care to avoid holding the following sections when handling the modules:
 - Exposed area of the printed circuit board
 - Terminal electrode sections