

PART NO.	MATERIAL	COLOR	DIM. "A"	DIM. "B"	DIM. "C"	DIM. "D"	STYLE NO.	
FM-1	EPDM RUBBER, 30 SHORE A (RMS-166)	BLACK	1.3 [.05]	1.5 [.06]	1.9 [.07]	32.3 [1.27]	1	
FM-2	EPDM RUBBER, 40 SHORE A (RMS-180)				3 [.12]	22.2 [.88]	2	
FM-3	EPDM RUBBER, 30 SHORE A (RMS-166)				18.5 [.73]	56 [2.20]	3	
FM-4	EPDM RUBBER, 40 SHORE A (RMS-180)		2.5 [.10]	2 [.08]	14 [.55]	53.8 [2.12]		
FM-5	SILICONE RUBBER, 40 SHORE A (RMS-316)		0.7 [.03]	1.5 [.06]	24 [.94]	73 [2.87]		
FM-6	SILICONE RUBBER, 40 SHORE A (RMS-316)		0.7 [.03]	N/A	N/A	4.3 [.17]	21 [.83]	4
FM-7	SILICONE RUBBER, 40 SHORE A (RMS-316)		N/A	N/A	N/A	N/A	N/A	N/A
FM-8	EPDM RUBBER, 30 SHORE A (RMS-166)		N/A	N/A	N/A	N/A	N/A	N/A
FM-9	EPDM RUBBER, 40 SHORE A (RMS-180)		N/A	N/A	N/A	N/A	N/A	N/A

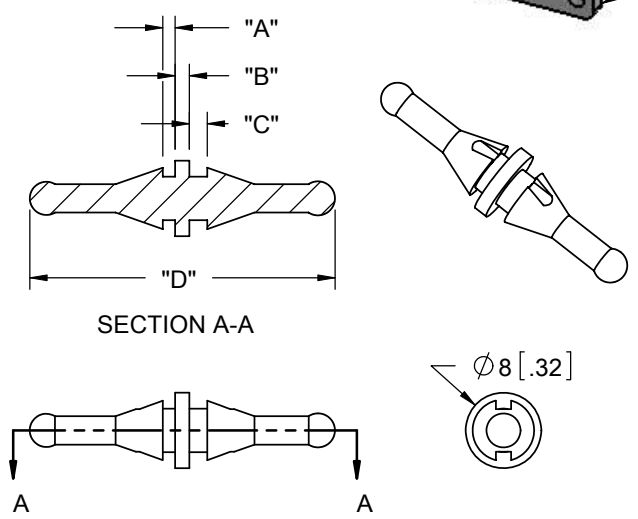

TO PULL THROUGH A $\varnothing 5 \pm 1 [.197 \pm .039]$ HOLE, WITH MAXIMUM 1.4 [.055] PANEL AND 2 [.079] FAN THICKNESS

STYLE 1

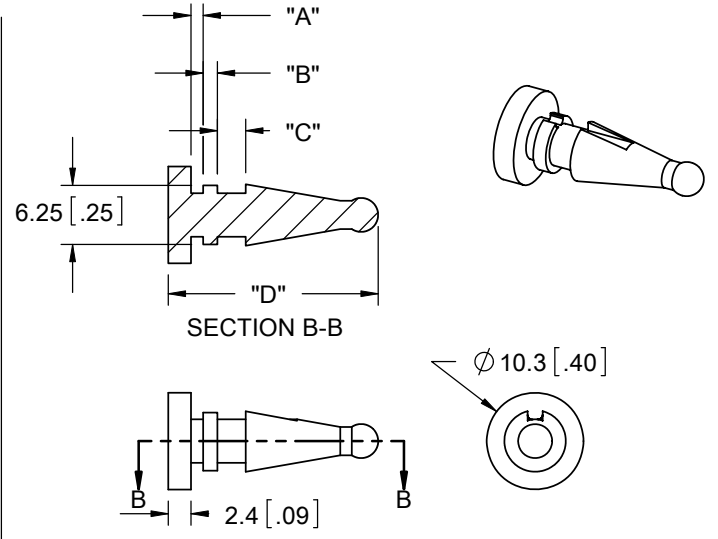

TO PULL THROUGH A $\varnothing 5 \pm 1 [.197 \pm .039]$ HOLE, WITH MAXIMUM 1.4 [.055] PANEL AND 3.1 [.122] FAN THICKNESS

STYLE 2

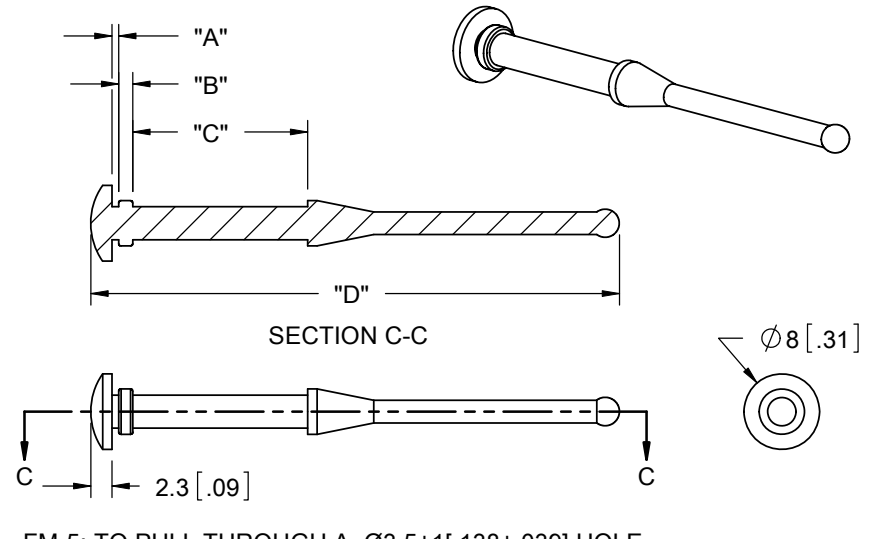

FM-5: TO PULL THROUGH A $\varnothing 3.5 \pm 1 [.138 \pm .039]$ HOLE, WITH MAXIMUM 0.8 [.031] PANEL AND 20 $\pm 0.5 [.787]$ FAN THICKNESS.

FM-6: TO PULL THROUGH A $\varnothing 4.3 \pm 0.2 [.161 \pm .008]$ HOLE, WITH MAXIMUM 3 [.118] PANEL AND 15 [.591] FAN THICKNESS.

FM-7: TO PULL THROUGH A $\varnothing 3.5 \pm 1 [.138 \pm .039]$ HOLE, WITH MAXIMUM 0.8 [.031] PANEL AND 25-28 [.98-1.10] FAN THICKNESS.

STYLE 3

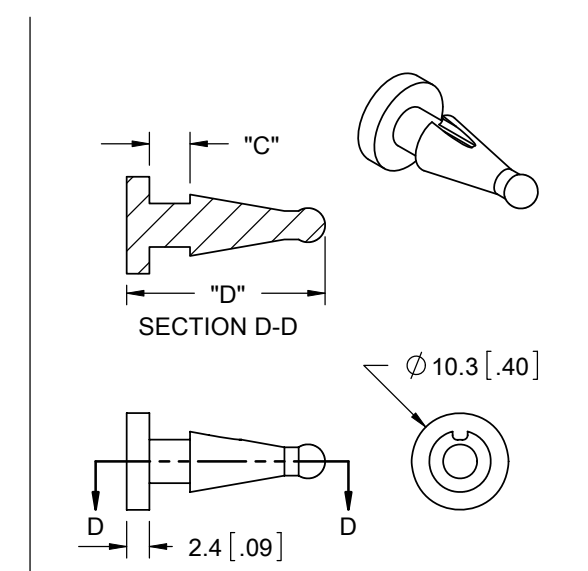

TO PULL THROUGH A $\varnothing 5 \pm 1 [.197 \pm .039]$ HOLE, WITH 5.4 [.213] MAXIMUM TOTAL THICKNESS

STYLE 4

NOTES:
1. ALTERNATE UNITS FOR REFERENCE ONLY

REV.	DESCRIPTION	ENGR.	DATE
D	ADDED FM-8 / -9, SEE CO 200544	SK	06.23.10
C	SEE CO 200399	SK	07/29/09
B	SEE CO 200074	SK	11/30/07
A	RELEASED FOR PRODUCTION, SEE ECN #1206	SK	08/11/06

TITLE: FAN MOUNT				DWG IN mm [IN]		FINAL	
CREATED USING SOLIDWORKS	FILE #: FM-X	DWN: SK	APP: SK	PART #			
TOLERANCES UNLESS NOTED	SHEET: 1 OF 1	SHEET SIZE: B	DT: 08/11/06	CHKD: SJ	SEE TABLE		
0-10=±0.1	RE: RICHCO, INC.		RICHCO, INC.		PRINT TYPE		
10.01-30=±0.3			ENG@RICHCO-INC.COM		CA		
30.01-50=±0.5			(773) 539-4060				
ANG.=±1°							