

ULTRA MINIATURE 2-POLES 2A (LOW PROFILE SIGNAL RELAY) FTR-B3 SERIES

RoHS compliant

■ FEATURES

- DPDT 2A
- Ultra miniature low profile relay with high heat resistant material
- Height: 5.45mm, Weight: 0.85g, Mounting space: 87mm²
- Adopted superior contact spring for high frequency characteristic
- Comply with Telcordia / FCC standard
 - Isolation distance: min. 1.6mm
 - Dielectric strength between coil and contact: 1500VAC
 - Surge strength: 2500V
- Low power: Non-latch: 140mW (230mW at 24V)
Latch: 100mW (120mW at 24V)
- High reliable bifurcated gold overlay silver contact
- UL, CSA recognized. Confirms to IEC 60950, UL1950, EN60950. Spacing & high breakdown voltage (Basic insulation, 150 working volts, pollution degree 2).
- RoHS compliant since date code: 0431B8
Please see page 10 for more information

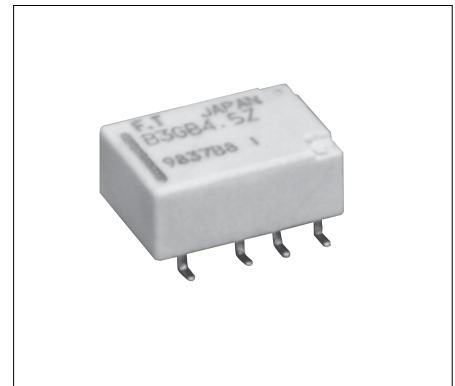

FTR-B3 Series

■ ORDERING INFORMATION

[Example] FTR-B3 G B 012 Z -B 10
 (a) (b) (c) (d) (e) (f) (g)

(a)	Series Name	FTR-B3 series
(b)	Terminal Type	C: through hole G: surface mount S: surface mount, space saving
(c)	Operation Function	A: standard type B: latching type (1 coil)
(d)	Rated voltage of coil	1.5 : 1.5 VDC 009 : 9VDC 003 : 3VDC 012: 12 VDC 4.5 : 4.5VDC 024 : 24VDC 006: 6VDC
(e)	Contact material	Z: gold overlay silver nickel (standard) P: gold overlay silver palladium
(f)	Relay enclosing direction*	B: standard enclosing direction
(g)	Number of relays per reel*	10: 1,000 (standard)

Remarks: Actual marking on relay would not carry code FTR and be as below:

Ordering code: FTR-B3GA012Z-B10

Actual marking: B3GA012Z

Note: *: - Only surface mount types (G and S) are applicable
 - All relays are packaged in tubes unless P/N ends with -B10

■ PART NUMBERS

Standard type

Ordering Part Number	Series	Terminal Type	Operation	Coil Voltage	Contact Material		
FTR-B3CA1.5Z	FTR-B3	C: through hole	A: non-latch	1.5	Z: Au-Ag-Ni P: Au-Ag-Pd		
FTR-B3CA003Z				3			
FTR-B3CA4.5Z				4.5			
FTR-B3CA006Z				6			
FTR-B3CA009Z				9			
FTR-B3CA012Z				12			
FTR-B3CA024Z				24			
FTR-B3GA1.5Z		G: surface mount		A: non-latch		1.5	
FTR-B3GA003Z						3	
FTR-B3GA4.5Z						4.5	
FTR-B3GA006Z						6	
FTR-B3GA009Z						9	
FTR-B3GA012Z						12	
FTR-B3GA024Z						24	
FTR-B3SA1.5Z		S: space saving surface mount				A: non-latch	1.5
FTR-B3SA003Z							3
FTR-B3SA4.5Z							4.5
FTR-B3SA006Z							6
FTR-B3SA009Z							9
FTR-B3SA012Z							12
FTR-B3SA024Z							24

FTR-B3 Series

Latching type (1 coil)

Ordering Part Number	Series	Terminal Type	Operation	Coil Voltage	Contact Material		
FTR-B3CB1.5Z	FTR-B3	C: through hole	B: latch	1.5	Z: Au-Ag-Ni P: Au-Ag-Pd		
FTR-B3CB003Z				3			
FTR-B3CB4.5Z				4.5			
FTR-B3CB006Z				6			
FTR-B3CB009Z				9			
FTR-B3CB012Z				12			
FTR-B3CB024Z				24			
FTR-B3GB1.5Z		G: surface mount		B: latch		1.5	
FTR-B3GB003Z						3	
FTR-B3GB4.5Z						4.5	
FTR-B3GB006Z						6	
FTR-B3GB009Z						9	
FTR-B3GB012Z						12	
FTR-B3GB024Z						24	
FTR-B3SB1.5Z		S: space saving surface mount				B: latch	1.5
FTR-B3SB003Z							3
FTR-B3SB4.5Z							4.5
FTR-B3SB006Z							6
FTR-B3SB009Z							9
FTR-B3SB012Z							12
FTR-B3SB024Z							24

FTR-B3 Series

■ COIL DATA CHART

Standard type

Coil Voltage	Nominal Voltage (VDC)	Max. Coil Voltage* ¹	Coil Resistance (±10%)	Must Operate Voltage* ²	Must Release Voltage* ²	Nominal Power (mW)
1.5	1.5	3.53 VDC	16.1 Ω	1.13 VDC	0.15 VDC	140
003	3	7.05 VDC	64.3 Ω	2.25 VDC	0.3 VDC	
4.5	4.5	10.58 VDC	145 Ω	3.38 VDC	0.45 VDC	
006	6	14.10 VDC	257 Ω	4.5 VDC	0.6 VDC	
009	9	21.15 VDC	579 Ω	6.75 VDC	0.9 VDC	
012	12	28.20 VDC	1,028 Ω	9.0 VDC	1.2 VDC	
024	24	56.40 VDC	2,504 Ω	18.0 VDC	2.4 VDC	230

Latching type (1 coil)

Coil Voltage	Nominal Voltage (VDC)	Max. Coil Voltage* ¹	Coil Resistance (±10%)	Must Operate Voltage* ²	Must Release Voltage* ²	Nominal Power (mW)
1.5	1.5	3.53 VDC	22.5 Ω	1.13 VDC	-0.13 VDC	100
003	3	7.05 VDC	90 Ω	2.25 VDC	-2.25 VDC	
4.5	4.5	10.58 VDC	203 Ω	3.38 VDC	-3.38 VDC	
006	6	14.10 VDC	360 Ω	4.5 VDC	-4.5 VDC	
009	9	21.15 VDC	810 Ω	6.75 VDC	-6.75 VDC	
012	12	28.20 VDC	1,440 Ω	9.0 VDC	-9.0 VDC	
024	24	56.40 VDC	4,800 Ω	18.0 VDC	-18.0 VDC	120

* Pulse driven

Note: All values in the table are measured at 20°C.

FTR-B3 Series

■ SPECIFICATIONS

Item		Non-latch Type	Latching Type
		FTR-B3 () A	FTR-B3 () B
Contact	Arrangement	2Form C	
	Contact material	Gold overlay silver nickel / Gold overlay silver palladium	
	Contact type	Bifurcated contacts (cross-bar)	
	Contact resistance (initial value)	75mΩ , maximum (6VDC, 1A)	
	Contact rating	30VDC 1A /125VAC 0.3A (resistive)	
	Maximum carrying/switching current	2A	
	Maximum switching power	62.5 VA / 30W	
	Maximum switching voltage	250 VAC, 220 VDC	
	Minimum switching load *1	10mVDC, 0.01mA*1	
Coil	Nominal power (at 20° C)	140mW to 230mW	100mW to 120mW
	Operate power (at 20° C)	80mW to 130mW	57mW to 68mW
	Operating temperature (no frost)	-40° C to +85° C	
Time Value	Operate (at nominal voltage, without bounce)	3ms maximum	
	Release (at nominal voltage, without bounce)	3ms maximum	
Life	Mechanical	50 x 10 ⁶ ops. min. (at 3Hz)	20 x 10 ⁶ ops. min. (at 3Hz)
	Electrical (resistive load)	100 x 10 ³ operations min. at 1A 30VDC (at 0.5Hz) 100 x 10 ³ operations min. at 0.3A 125VDC (at 0.5Hz)	
Other	Vibration resistance	Malfunction	10 to 55 Hz at double amplitude of 3.3mm
		Endurance	10 to 55 Hz at double amplitude of 5mm
	Shock resistance	Malfunction	Min. 750 m/s ²
		Endurance	Min. 1000 m/s ²
	Weight	Approximately 0.8g	

*1 Minimum switching loads mentioned above are reference values. Please perform the confirmation test with the actual load before production since reference values may vary according to switching frequencies, environmental conditions and expected reliability levels.

FTR-B3 Series

■ INSULATION

Item		FTR-B3
Resistance (initial) (500 VDC)		Minimum 1,000 MΩ 1 min.
Dielectric Strength	open contacts	1,000 VAC (50/60 Hz) 1 min.
	coil and contacts	1,500 VAC (50/60 Hz) 1 min.
	adjacent contacts	1,000 VAC (50/60 Hz) 1 min.
Surge Voltage (coil and contact)		2,500 V 2 x 10μs standard wave
Clearance	adjacent contacts	1.0mm
	open contacts	0.28mm
	coil and contacts	1.0mm
Creepage	adjacent contacts	1.0mm
	open contacts	0.28mm
	coil and contacts	1.60mm

■ SAFETY STANDARDS

Type	Compliance	Contact rating
UL	UL 508	Flammability: UL 94-V0 (plastics) 0.5A, 125VAC (resistive) 1A, 30VDC (resistive) 0.3A, 110VDC (resistive) 2A, 30VDC (resistive)
	E63615	
CSA	C22.2 No. 14 LR 40304-58	

■ CHARACTERISTIC DATA

- Non-latch

Operation
(return time characteristics)

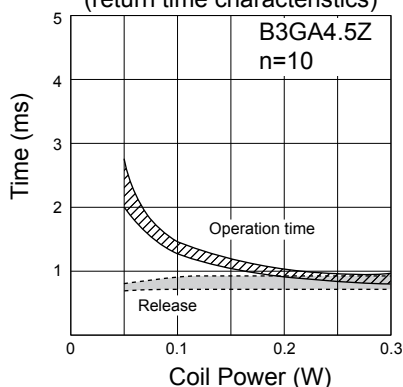

Coil Temperature Rise

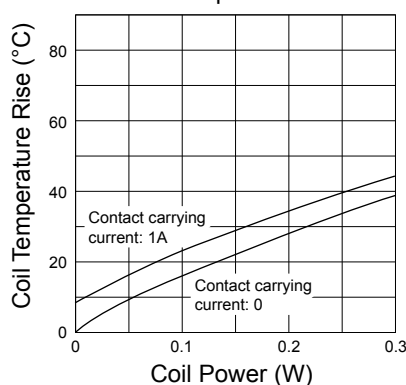

Ambient Temperature
(maximum applied voltage,
operating voltage characteristics)

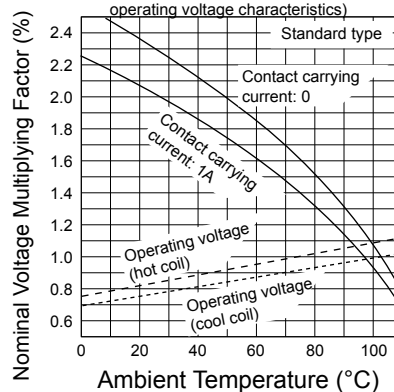

Maximum Switching Power

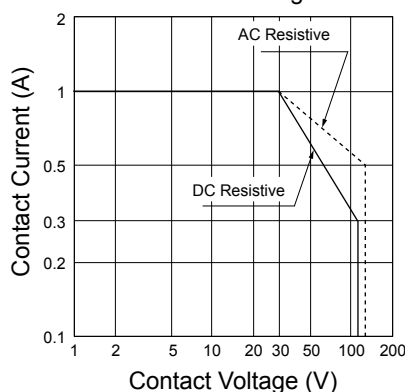

Life Curve

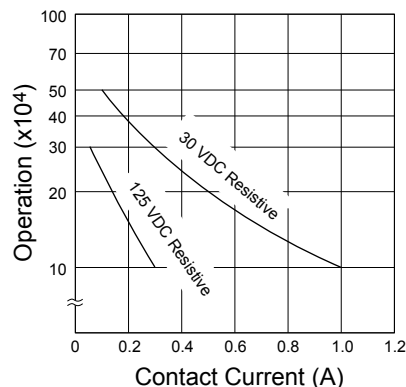

FTR-B3 Series

- Latching type (1 coil)
Operation
(return time characteristics)

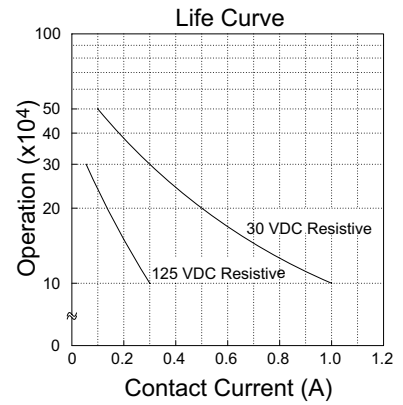
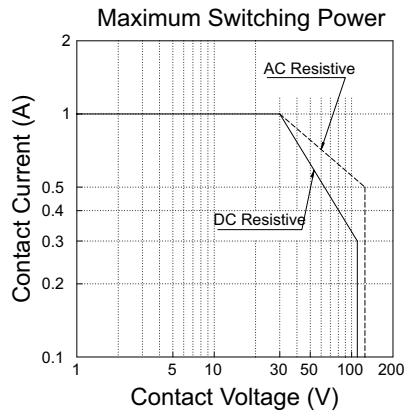
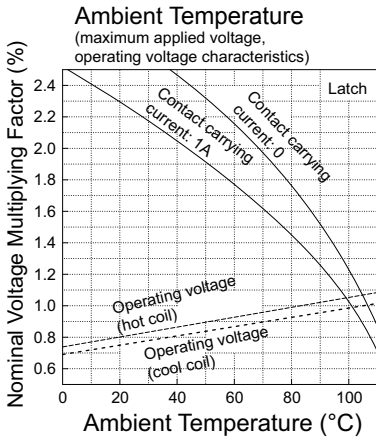
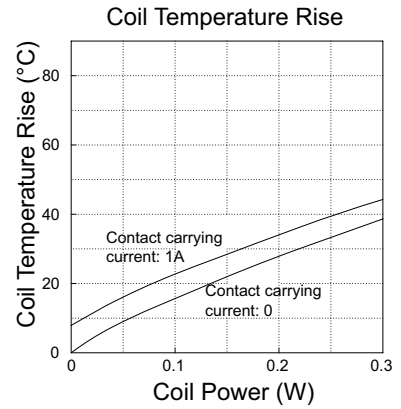
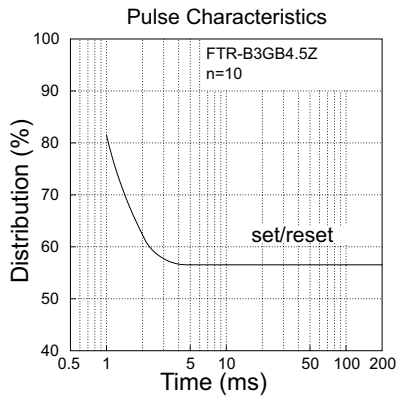
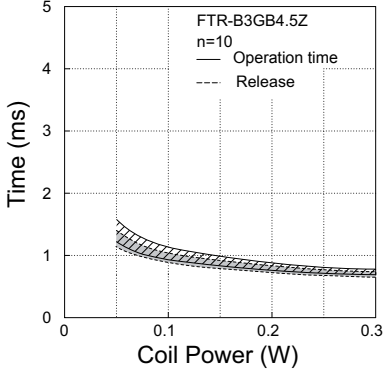

■ REFERENCE DATA

- Non-latch

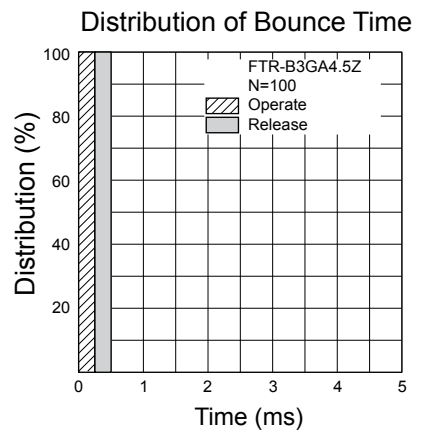
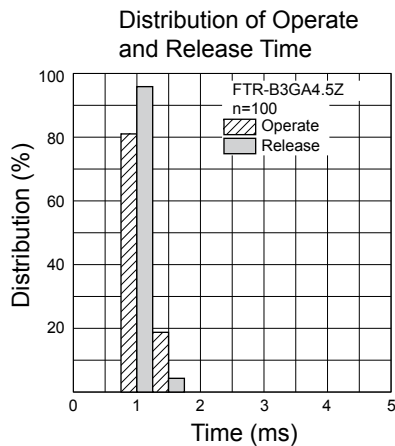
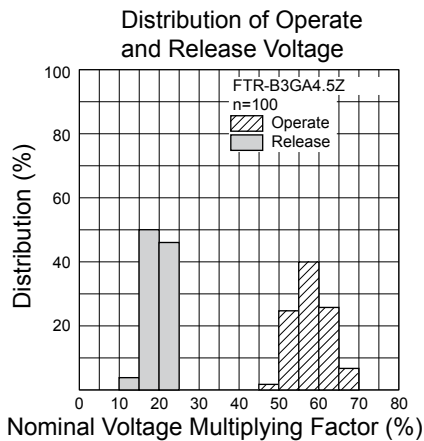

FTR-B3 Series

Distribution of Contact Resistance

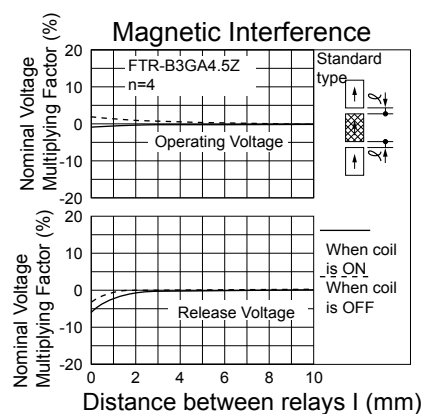
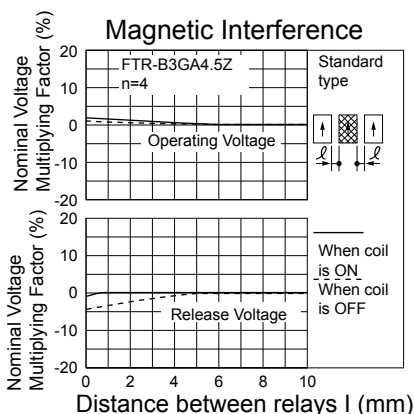
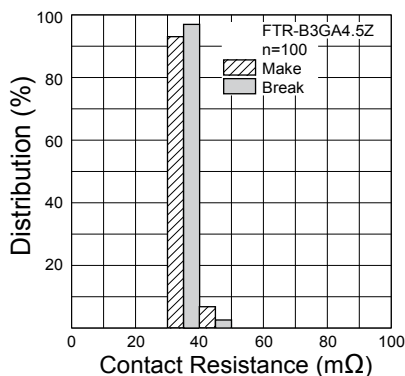

High Frequency Characteristics

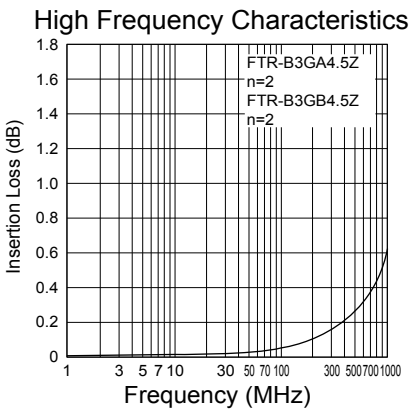
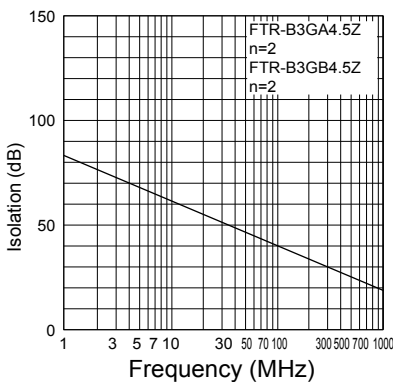

- Latching type (1 coil)

Distribution of Operate and Release Voltage

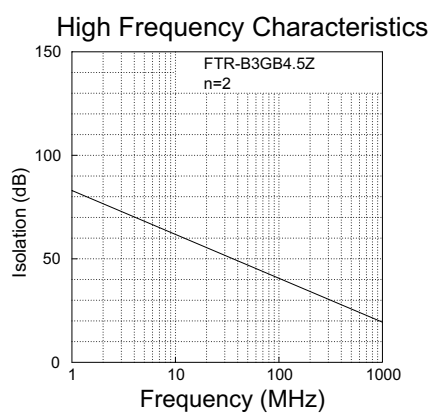
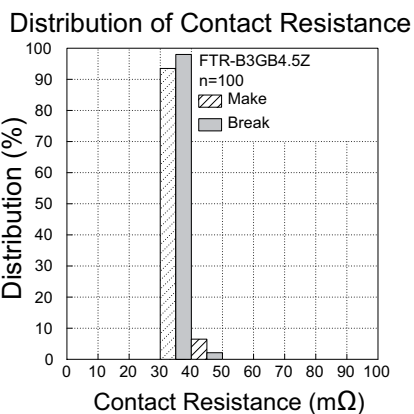
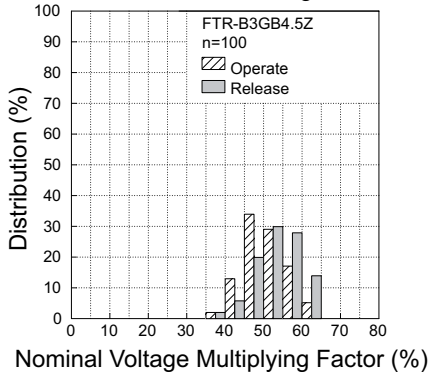

High Frequency Characteristics

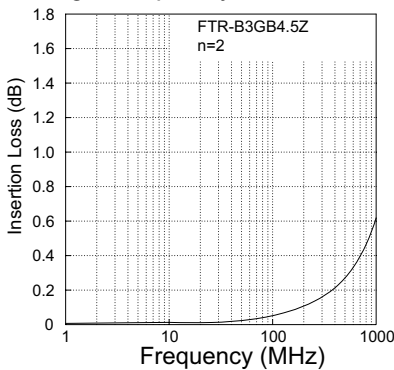

FTR-B3 Series

■ DIMENSIONS

FTR-B3S() () - Space saving type

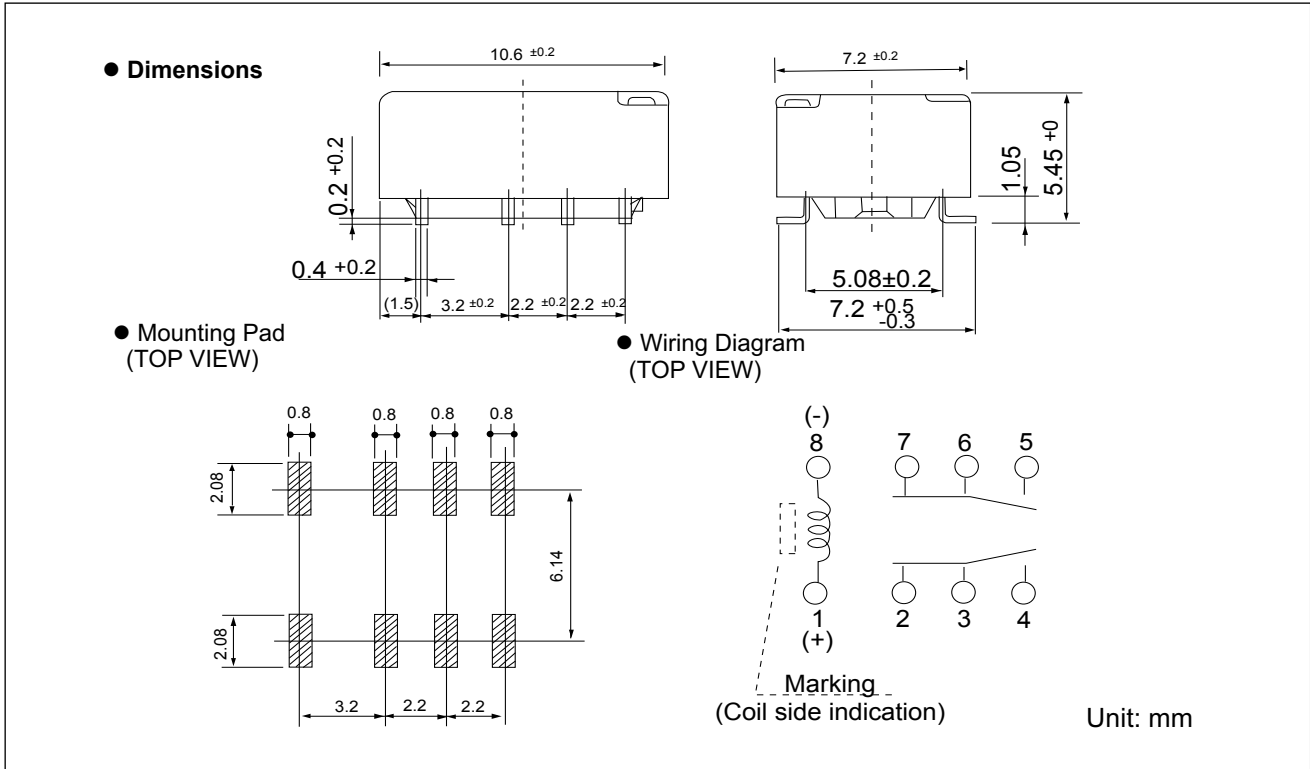

■ PACKAGING SPECIFICATIONS

● Packaging Method

- Packaging Standard: JIS C 0806
- Taping Type: TB 1612
- Reel Type: R16D
- Quantity of 1reel: 1000 pieces

● Packaging Orientation Code: B

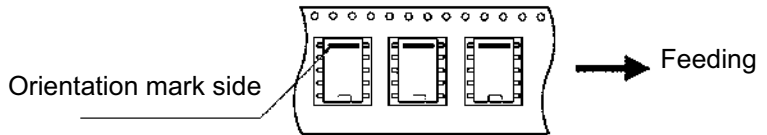

● (2) Dimensions

- Reel dimensions

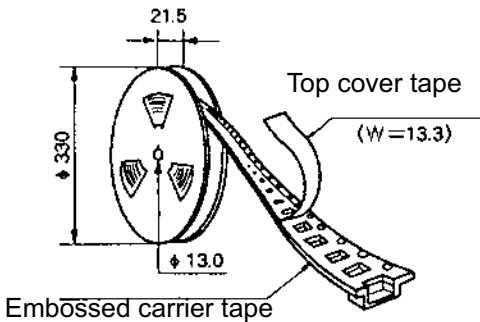

● Tape Dimensions

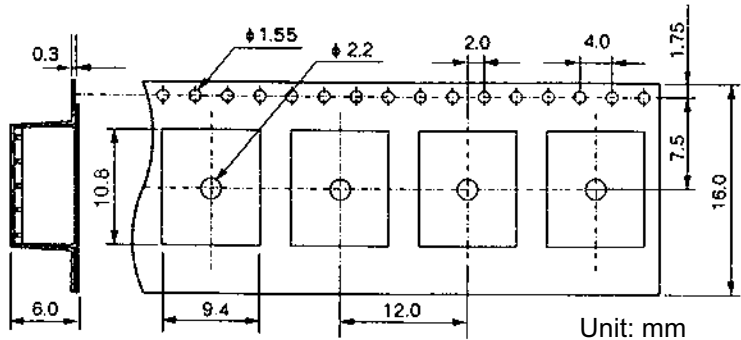

Note: Relays are sold in packs of 1000 pieces, please order 1000 pieces as one unit.

■ RECOMMENDED SOLDERING CONDITIONS (TEMPERATURE PROFILE)

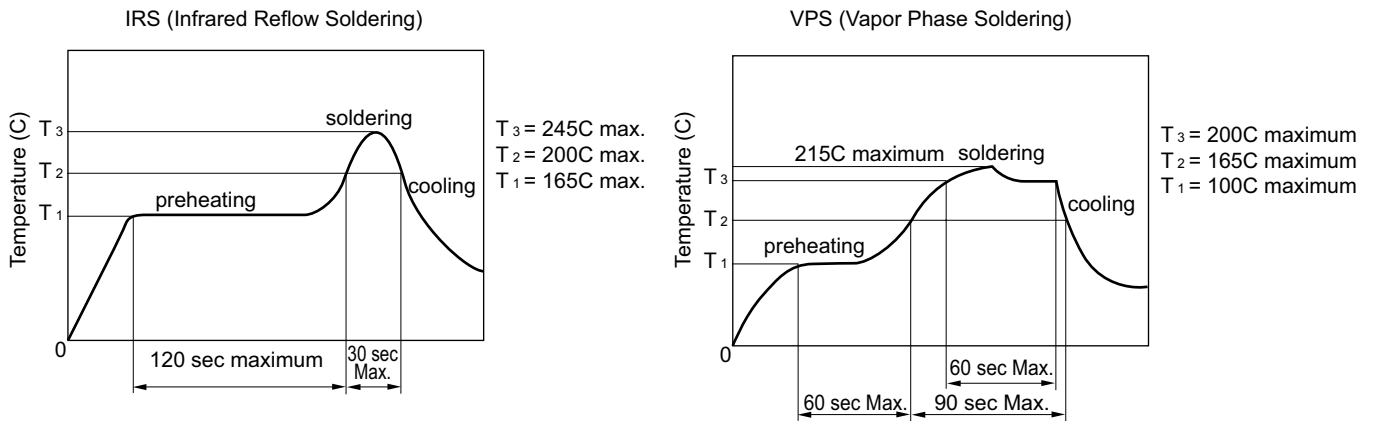

- Note: 1. Temperature profiles show the temperature of PC board surface.
2. Please perform soldering test with your actual PC board before mass production, since the temperatures of PC board surfaces vary according to the size of PC board, status of parts mounting and heating method.

■ PRECAUTIONS

- For details on general precautions, refer to the section on technical descriptions.
- Since this is a polar relay, follow the instructions of the internal wiring diagram for the +- connections of the coil.
- Note that the terminal array and internal wiring of the surface mount relay are a top view

©2008 Fujitsu Components America, Inc. All rights reserved. All trademarks or registered trademarks are the property of their respective owners.

Fujitsu Components America or its affiliates do not warrant that the content of datasheet is error free. In a continuing effort to improve our products Fujitsu Components America, Inc. or its affiliates reserve the right to change specifications/datasheets without prior notice.
Rev. February 4, 2008.

RoHS Compliance and Lead Free Relay Information

1. General Information

- Relays produced after the specific date code that is indicated on each data sheet are lead-free now. All of our signal and power relays are lead-free. Please refer to Lead-Free Status Info. (<http://www.fujitsu.com/us/downloads/MICRO/fcai/relays/lead-free-letter.pdf>)
- Lead free solder paste currently used in relays is Sn-3.0Ag-0.5Cu. From February 2005 forward Sn-3.0CU-Ni will be used for the FTR-B3 and FTR-B4 series relays.
- All signal and power relays also comply with RoHS. Please refer to individual data sheets. Relays that are RoHS compliant do not contain the 5 hazardous materials that are restricted by RoHS directive (lead, mercury, chromium IV, PBB, PBDE).
- It has been verified that using lead-free relays in lead assembly process will not cause any problems (compatible).
- "LF" is marked on each outer and inner carton. (No marking on individual relays).
- To avoid leaded relays (for lead-free sample, etc.) please consult with area sales office.
 - We will ship leaded relays as long as the leaded relay inventory exists.

Note: Cadmium was exempted from RoHS on October 21, 2005. (Amendment to Directive 2002/95/EC)

2. Recommended Lead Free Solder Profile

- Recommended solder paste Sn-3.0Ag-0.5Cu and Sn-3.0 Cu-Ni (only FTR-B3 and FTR-B4 from February 2005).

Reflow Solder condition

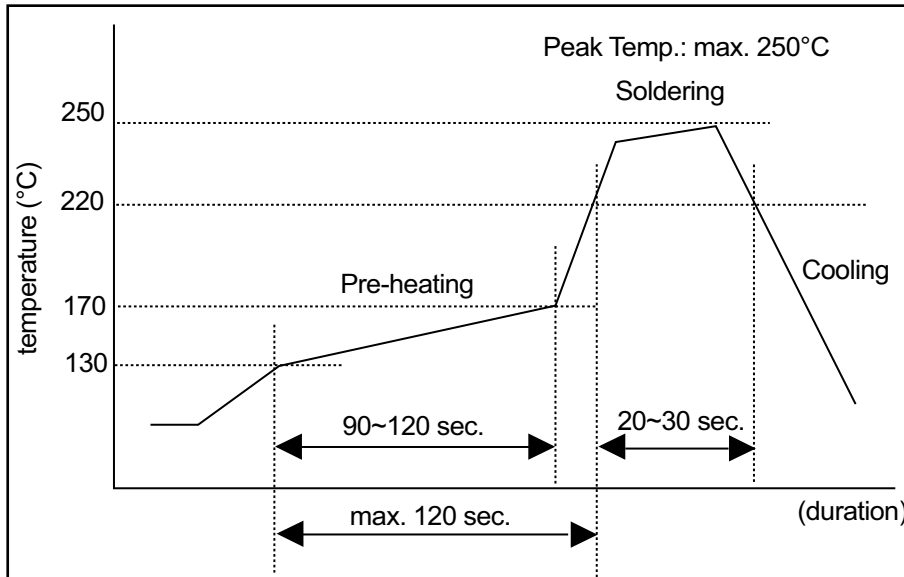

Flow Solder condition:

Pre-heating: maximum 120°C
Soldering: dip within 5 sec. at 260°C solder bath

Solder by Soldering Iron:

Soldering Iron
Temperature: maximum 360°C
Duration: maximum 3 sec.

We highly recommend that you confirm your actual solder conditions

3. Moisture Sensitivity

- Moisture Sensitivity Level standard is not applicable to electromechanical relays.

4. Tin Whisker

- SnAgCu and SnCuNi solder is known as low risk of tin whisker. No considerable length whisker was found by our in-house test.