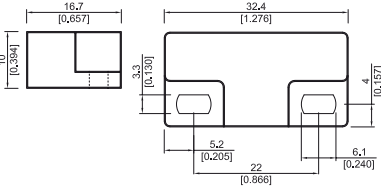
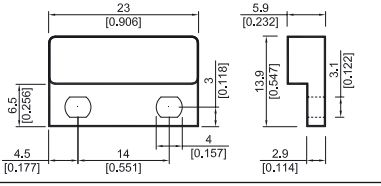
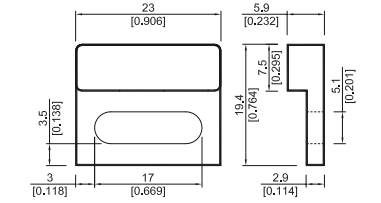
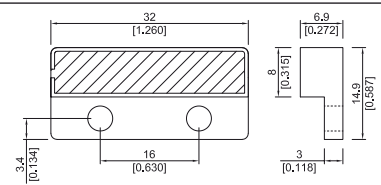
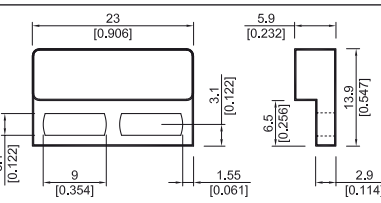
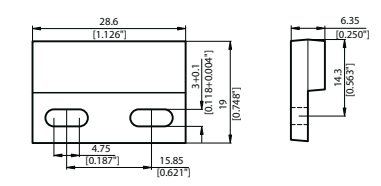

Eine Beschreibung der unterschiedlichen Werkstoffe finden Sie im Datenbuch auf den Seiten 41-45.

Magneten in Standardgehäuse			
Abmessungen	Werkstoff	Typ magn. Moment (x 10 ⁻⁵)	Artikel Nr.
	AlNiCo	2.22	M2 250000002
	AlNiCo	2.22	M4 250000004
	AlNiCo	2.22	M5 250000005
	AlNiCo	2.22	M12 250000012
	AlNiCo	2.22	M13 250000013
	AlNiCo	2.22	M21 250000021
<p>Alle Maße in mm. Weitere Standardausführungen auf Anfrage.</p>			