



TS494

Voltage Mode PWM Controller

SOP-16



DIP-16



Supply Voltage Range 7 V to 40V
Output Driving Current 200mA
Oscillator Frequency up to 200KHz

General Description

The TS494 incorporates on a single monolithic chip all the functions required in the construction of a pulse-width-modulation control circuit. Designed primarily for power supply control, these devices offer the systems engineer the flexibility to tailor the power supply control circuitry to his application.

The TS494 contains an error amplifier, an on-chip adjustable oscillator, a dead-time control comparator, pulse-steering control flip-flop, a 5-volt, 5% precision regulator, and output-control circuits. The error amplifier exhibits a common-mode voltage from $-0.3V$ to $V_{CC} - 2V$. The dead-time control comparator has a fixed offset that provides approximately 5% dead time when externally altered. The on-chip oscillatory be bypassed by terminating R_T (pin 6) to the reference output and providing a sawtooth input to C_T (pin 5), or it may be used to drive the common circuits in synchronous multiple-rail power supplies. The uncommitted output transistor provide either common-emitter or emitter-follower output capability. Each device provides for push-pull or single-ended output operation, which may be selected through the output-control function. The architecture of these devices prohibits the possibility of either output being pulsed twice during push-pull operation.

The TS494 is offered in SOP-16 and DIP-16 package.

Features

- ◇ Complete PWM Power Control Circuitry
- ◇ Uncommitted Outputs for 200mA Sink or Source Current
- ◇ Output Control Selects Single-Ended or Push –Pull Operation
- ◇ Internal Circuitry Prohibits Double Pulse at Either Output
- ◇ Variable Dead-Time Provides Control over Total Range
- ◇ Internal Regulator Provides a Stable 5-V Reference Supply with 5% Tolerance
- ◇ Circuit Architecture Allows Easy Synchronization

Pin Assignment

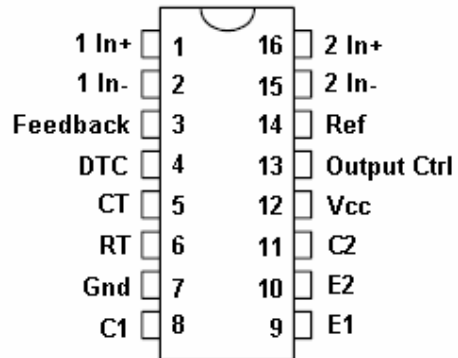

Applications

- ◇ Charger
- ◇ DC to DC converters

Ordering Information

Part No.	Operating Temp.	Package
TS494CD	0 ~ +70 °C	DIP-16
TS494CS		SOP-16



Function Block Diagram

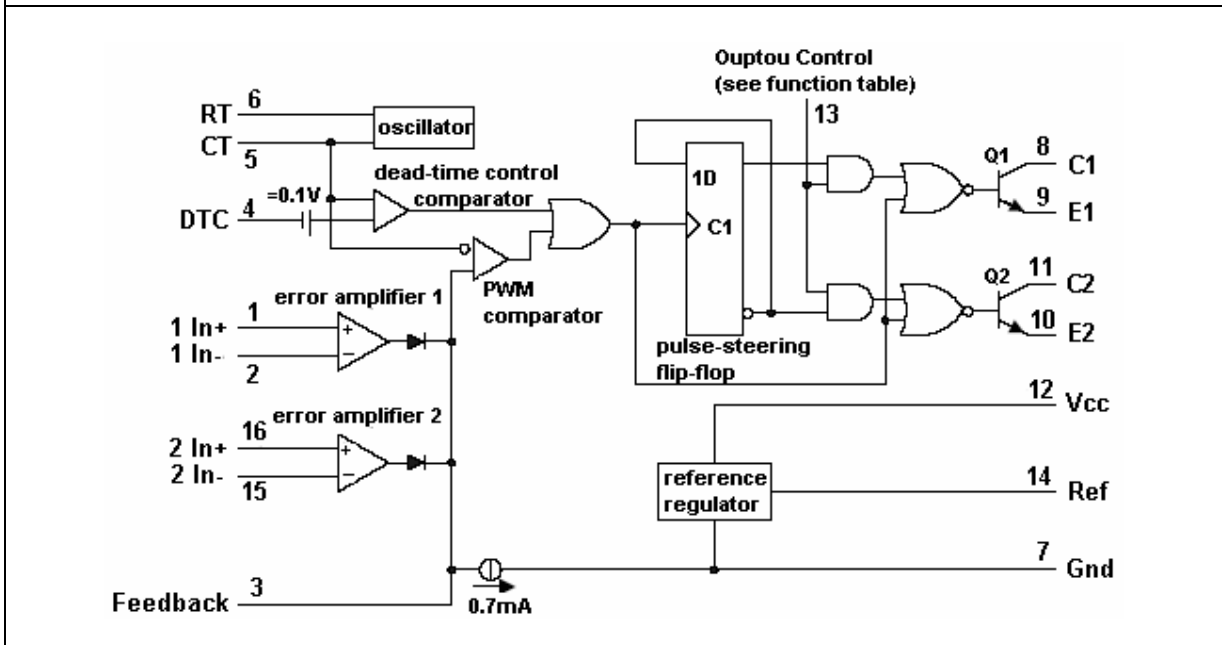

Absolute Maximum Rating

Rating	Symbol	Value	Unit
Power Supply Voltage	V _{cc}	40	V
Collector Output Voltage	V _{c1} , V _{c2}	40	V
Collector Output Current (each transistor)	I _{c1} , I _{c2}	250	mA
Amplifier Input Voltage Range	V _{IR}	-30 ~ +40	V
Power Dissipation @ T _a ≤ 45 °C	P _d	1	W
Thermal Resistance, Junction to Ambient	R _{θJA}	80	°C/W
Operating Junction Temperature	T _j	125	°C
Storage Temperature Range	T _{stg}	-55 ~ +125	°C
Operating Ambient Temperature Range	T _a	0 ~ +70	°C
Derating Ambient Temperature	T _a	45	°C

Recommended Operating Conditions

Rating	Symbol	Min.	Typ.	Max	Unit
Power Supply Voltage	V _{cc}	7	15	40	V
Collector Output Voltage	V _{c1} , V _{c2}	--	30	40	V
Collector Output Current (each transistor)	I _{c1} , I _{c2}	--	--	200	mA
Amplifier Input Voltage	V _{in}	-0.3	--	V _{cc} -2.0	V
Current Into Feedback Terminal	I _{fb}	--	--	0.3	mA
Reference Output Current	I _{ref}	--	--	10	mA
Timing Resistor	R _T	1.8	30	500	KΩ
Timing Capacitor	C _T	0.0047	0.001	10	uF
Oscillator Frequency	F _{osc}	1	40	200	KHz



Electrical Characteristics ($T_a=25^\circ\text{C}$, $V_{CC} = 15\text{V}$, $C_T= 0.01\mu\text{F}$, $R_T= 12\text{k}\Omega$; unless otherwise specified.)

REFERENCE SECTION

Parameter	Test Conditions*	Min	Typ	Max	Unit
Output voltage (Vref)	$I_o=1\text{mA}$	4.75	5	5.25	V
Line regulation	$V_{CC}= 7\text{V to } 40\text{V}$	--	2.0	25	mV
Load regulation	$I_o= 1\text{mA to } 10\text{mA}$	--	3.0	15	
Output voltage change with temp.	$\Delta T_a=\text{Min to Max}$	--	0.2	1	%
Short-circuit output current***	$V_{\text{ref}}= 0$	15	35	75	mA

OSCILLATOR SECTION

Frequency	$C_T= 0.001\mu\text{F}$, $R_T= 30\text{k}\Omega$	--	40	--	%
Standard deviation of frequency****	$C_T= 0.001\mu\text{F}$, $R_T= 30\text{k}\Omega$	--	3.0	--	
Frequency change with voltage	$V_{CC}= 7\text{V to } 40\text{V}$	--	0.1	--	
Frequency change with temperature***	$C_T= 0.001\mu\text{F}$, $R_T= 30\text{k}\Omega$ $\Delta T_a= \text{Min to Max}$	--	--	12	

ERROR AMPLIFIER SECTION

Input offset voltage	$V_o= (\text{pin } 3)= 2.5\text{V}$	--	2.0	10	mV
Input offset current	$V_o= (\text{pin } 3)= 2.5\text{V}$	--	5.0	250	nA
Input bias current	$V_o= (\text{pin } 3)= 2.5\text{V}$	--	-0.1	-1.0	μA
Common-mode input voltage range	$V_{CC}= 7\text{V to } 40\text{V}$	-0.3 to $V_{CC}-2$			V
Open-loop voltage amplification	$\Delta V_o= 3\text{V}$, $R_L=2\text{k}\Omega$, $V_o= 0.5 \text{ to } 3.5\text{V}$	70	95	--	dB
Unity-gain bandwidth	$R_L= 2\text{k}\Omega$, $V_o= 0.5 \text{ to } 3.5\text{V}$	--	800	--	KHz
Common-mode rejection ratio	$\Delta V_o= 40\text{V}$	65	90	--	dB
Power Supply Rejection Ratio	$\Delta V_{CC}= 33\text{V}$, $V_o= 2.5\text{V}$, $R_L= 2\text{k}\Omega$	--	100	--	dB
Output sink current (pin 3)	$V_{ID}= -15\text{mV to } -5\text{V}$, $V(\text{pin}3)= 0.7\text{V}$	0.3	0.7	--	mA
Output source current (pin 3)	$V_{ID}= 15\text{mV to } 5\text{V}$, $V(\text{pin}3)= 3.5\text{V}$	2.0	-4.0	--	mA

OUTPUT SECTION

Collector off-state current	$V_{CE}= 40\text{V}$, $V_{CC}= 40\text{V}$	--	2.0	100	μA
Emitter off-state current	$V_{CC}= 40\text{V}$, $V_E= 0$	--	--	-100	
Collector-emitter saturation voltage	Common-emitter	$V_E= 0$, $I_c= 200\text{mA}$	--	1.1	V
	Emitter-follower	$V_c= 15\text{V}$, $I_E= -200\text{mA}$	--	1.5	
Output control input current	$V_I= V_{\text{ref}}$	--	--	3.5	mA

DEAD-TIME CONTROL SECTION

Input bias current (pin 4)	$V_I= 0 \text{ to } 5.25\text{V}$	--	-2.0	-10	μA
Maximum duty cycle, each output	$V_i(\text{pin } 4)= 0$, $C_T= 0.1\mu\text{F}$, $R_T= 12\text{k}\Omega$	--	45	50	%
Input threshold voltage(pin 4)	Zero duty cycle	--	3.0	3.3	V
	Maximum duty cycle	0	--	--	



Electrical Characteristics (continues)

PWM COMPARATOR SECTION

Parameter	Test Conditions*	Min	Typ	Max	Unit
Input threshold voltage (pin 3)	Zero duty cycle	--	4.0	4.5	V
Input sink current (pin 3)	V (pin 3)=0.7V	0.3	0.7	--	mA

TOTAL DEVICE

Standby supply current	pin 6 at Vref, all other inputs and outputs open	Vcc=15V	--	6.0	10	mA
		Vcc=40V	--	9.0	15	
Average supply current	Vi (pin4)= 2V, See Figure 1	--	7.5	--		

SWITCHING CHARACTERISTICS

Output voltage rise time	Common-emitter configuration, See Figure 3	--	100	200	ns
Output voltage fall time		--	25	100	
Output voltage rise time	Emitter-follower configuration, See Figure 4	--	100	200	
Output voltage fall time		--	40	100	

UNDERVOLTAGE LOCKOUT SECTION

Turn-on Threshold	Vcc increasing Iref = 1.0mA	5.5	6.43	7.0	V
-------------------	-----------------------------	-----	------	-----	---

Remark:

- All typical value except for temperature coefficient are at Ta= 25 °C
- For conditions shown as Min or Max, use the appropriate value specified under recommended operating conditions.
- All typical values except for parameter changes with temperature are at Ta= 25 °C
- Duration of the short-circuit should not exceed one second
- Standard deviation is a measure of the statistical distribution about the mean as derived from the formula

$$\sigma = \left[\sum_{n=1}^N \frac{(x_n - \bar{x})^2}{N - 1} \right]^{1/2}$$

- Temperature coefficient of timing capacitor and timing resistor not taken into account

Parameter Measurement Information

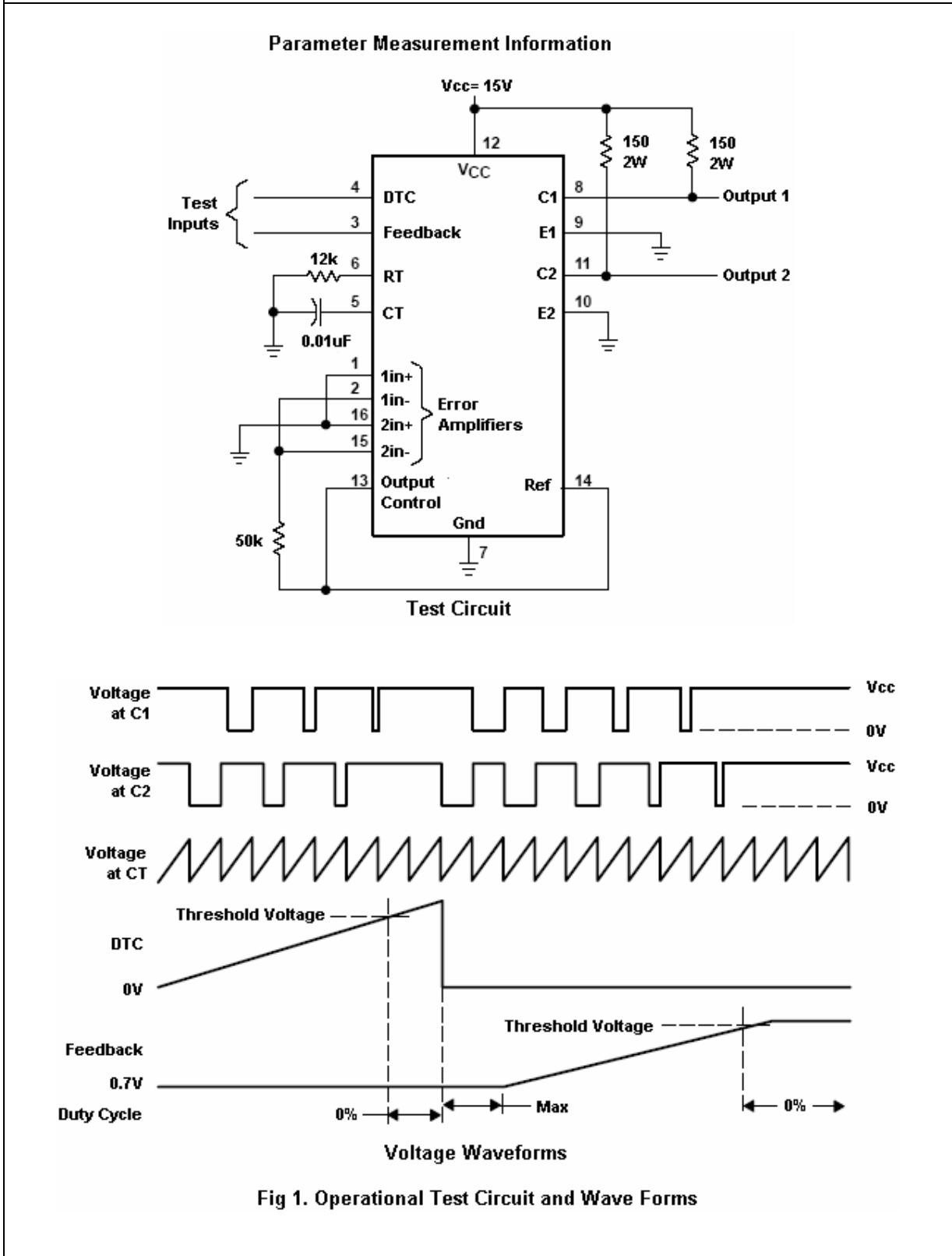

Parameter Measurement Information (continues)

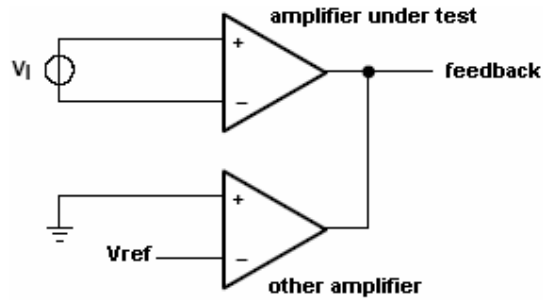
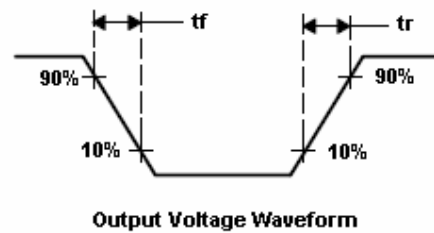
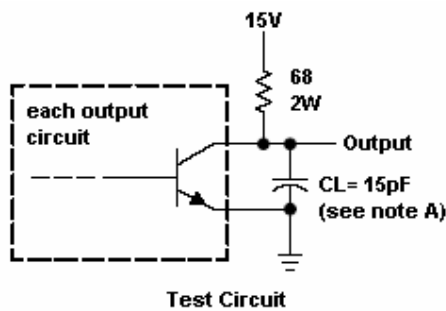
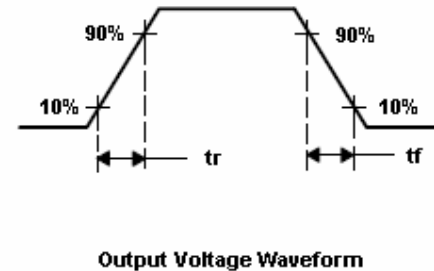
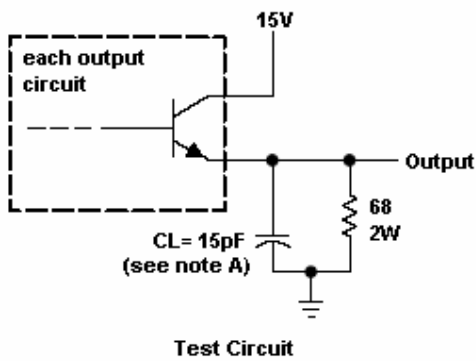

Fig 2. Amplifier Characteristics



note A: CL includes probe and jig capacitance

Fig 3. Common-Emitter Configuration



note A: CL includes probe and jig capacitance

Fig 4. Emitter-Follower Configuration

SOP-16 Mechanical Drawing

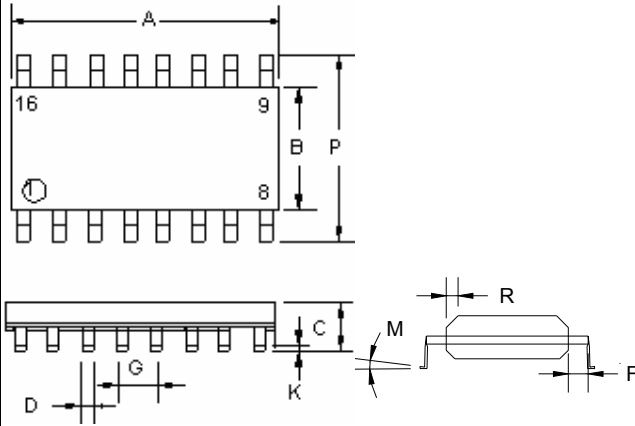

SOP-16 DIMENSION				
DIM	MILLIMETERS		INCHES	
	MIN	MAX	MIN	MAX
A	9.80	10.00	0.386	0.393
B	3.80	4.00	0.150	0.157
C	1.35	1.75	0.054	0.068
D	0.35	0.49	0.014	0.019
F	0.40	1.25	0.016	0.049
G	1.27 (typ)		0.05 (typ)	
K	0.10	0.25	0.004	0.009
M	0°	7°	0°	7°
P	5.80	6.20	0.229	0.244
R	0.25	0.50	0.010	0.019

DIP-16 Mechanical Drawing

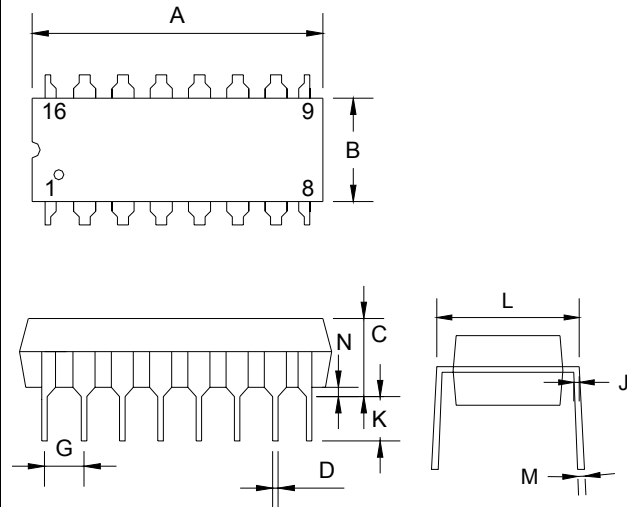

SOP-16 DIMENSION				
DIM	MILLIMETERS		INCHES	
	MIN	MAX	MIN	MAX
A	17.80	18.05	0.701	0.710
B	6.22	6.48	0.290	0.299
C	3.18	4.45	0.125	0.135
D	0.35	0.55	0.019	0.020
G	1.27 (typ)		0.05 (typ)	
J	0.25	0.31	0.010	0.012
K	3.25	3.35	0.128	0.132
L	7.75	8.00	0.305	0.315
M	-	10°	-	10°