

SP1662

QUAD 2-INPUT NOR GATE

The SP1662 comprises four 2-input OR gating functions in a single package. An internal bias reference voltage ensures that the threshold point remains in the centre of the transition region over the temperature range (-30°C to +85°C). Input pull-down resistors eliminate the need to tie unused inputs to V_{EE}.

FEATURES

- Gate Switching Speed 1 ns Typ.
- ECL II and ECL 10000-Compatible
- 50 Ω Line Driving Capability
- Operation With Unused I/Ps Open Circuit
- Low Supply Noise Generation

APPLICATIONS

- Data Communications
- Instrumentation
- PCM Transmission Systems

ORDERING INFORMATION

SP1662DG (Industrial - Ceramic DIL package)

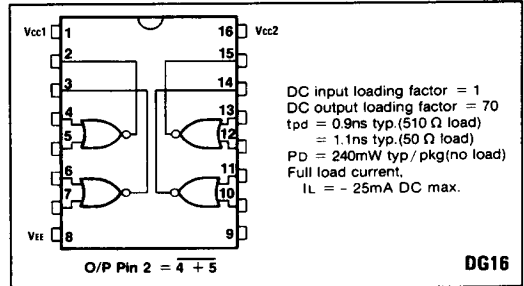

Fig.1 Logic diagram

ABSOLUTE MAXIMUM RATINGS

Power supply voltage	V _{CC} - V _{EE} 8V
Input voltages	0V to V _{EE}
Output source current	<40mA
Storage temperature range	-65°C to +150°C
Junction operating temperature	<175°C

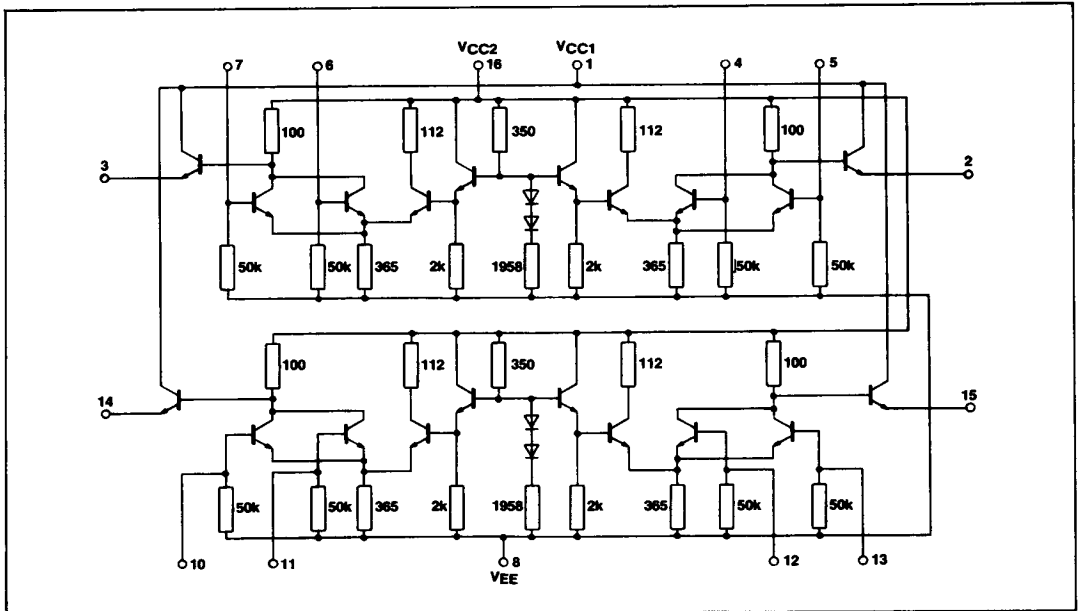

Fig.2 Circuit diagram

