

14W BTL AUDIO POWER AMPLIFIER

MB3732 MB3734

July 1988
Edition 2.0

14W BTL AUDIO POWER AMPLIFIER

The Fujitsu MB3732 and MB3734 are low-frequency high-power amplifiers with internal BTL (Bridged Output Trans Former-less) circuitry. Suitable for car stereos, the MB3732 and the MB3734 are packed in small plastic packages which have low thermal resistance. Designing for heat radiation can be executed at a low cost. The devices require few external components, so high density mounting is optimized.

The MB3732 and MB3734 comprise various protection functions, including an internal power-on pop noise reduction circuit.

- High power output : 14W typical
- Small plastic package : 7-pin SIP for the MB3732
9-pin SIP for the MB3734
- Minimum external components
- Low thermal resistance : 3°C/W in the MB3732
4°C/W in the MB3734
- On-chip power-on pop noise reduction circuit
- No breakdown : between pins is shorted or insertion is inverted
- Low distortion : THD = 0.07% typical
- Various protection circuits :
Power supply surge protection, Thermal protection
Load short protection, Over voltage protection
Output pin-to-DC short protection

ABSOLUTE MAXIMUM RATINGS (see NOTE) (T_C = 25°C)

Rating	Symbol	Value	Unit
Supply Voltage	V _{CC}	18	V
Supply Voltage (Surge)	V _{CCS}	50*	V
Output Current (Peak)	I _{OPEAK}	4.5	A
Power Dissipation	P _D	18	W
Operating Temperature (Case)	T _C	-20 to +75	°C
Storage Temperature	T _{STG}	-55 to +150	°C

Note: t_r ≤ 0.2 sec, t_r ≥ 1 msec

NOTE: Permanent device damage may occur if ABSOLUTE MAXIMUM RATINGS are exceeded. Functional operation should be restricted to the conditions as detailed in the operational sections of this data sheet. Exposure to absolute maximum rating conditions for extended periods may affect device reliability.

3



PLASTIC PACKAGE
SIP-07P-M01

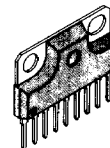

PLASTIC PACKAGE
SIP-09P-M02

PIN ASSIGNMENT

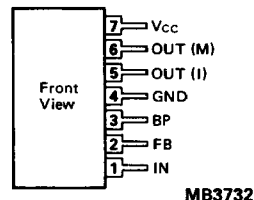

MB3732

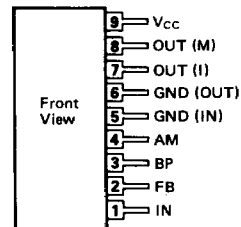

MB3734

This device contains circuitry to protect the inputs against damage due to high static voltages or electric fields. However, it is advised that normal precautions be taken to avoid application of any voltage higher than maximum rated voltages to this high impedance circuit.

3

Fig. 1 - MB3732 BLOCK DIAGRAM

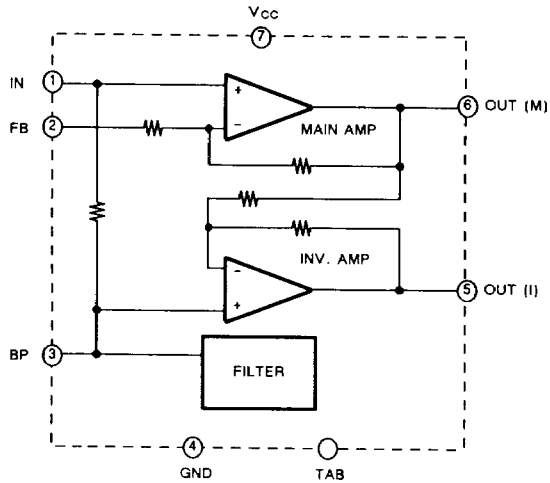
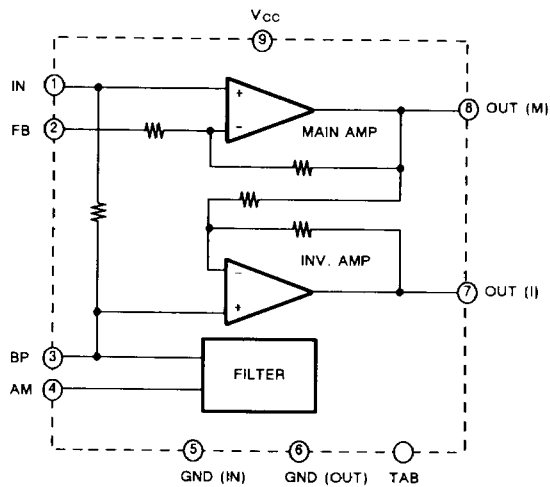

Fig. 2 - MB3734 BLOCK DIAGRAM





RECOMMENDED OPERATING CONDITIONS

Parameter	Symbol	Max	Unit
Power Supply Voltage	V_{CC}	8 to 16	V
Operating Temperature (Case)	T_C	-20 to +75	°C

3

ELECTRICAL CHARACTERISTICS

($T_C = 25^\circ\text{C}$, $V_{CC} = 13.2\text{V}$, $R_L = 4\Omega$, $f = 1\text{KHz}$)

Parameter	Symbol	Condition	Values			Unit
			Min	Typ	Max	
Quiescent Power Supply Current	I_Q	$V_{IN} = 0\text{V}$ $R_L = \infty$	—	80	160	mA
Voltage Gain	A_V	—	45	47	49	dB
Output Power	P_O	THD = 10%	10	14	—	W
		THD = 1%	—	10	—	
Total Harmonic Distortion	THD	$P_O = 1\text{W}$	—	0.07	0.5	%
Output Noise Voltage	V_{NO}	$R_g = 0\Omega$ BW = 20Hz to 20KHz	—	0.3	—	mV
		$R_g = 10\text{K}\Omega$ BW = 20Hz to 20KHz	—	0.5	1.0	
Input Resistance	R_{IN}	—	20	30	—	k Ω
Output Offset Voltage	V_{OFF}	—	—	± 0.1	± 0.3	V
DC Mute Supply Current	I_{CCQ}	$V_{3pin} = 0\text{V}$	—	15	—	mA
Audio Mute Attenuation	—	MB3734 Only	—	60	—	dB

Fig. 3 – MB3732 TEST CIRCUIT

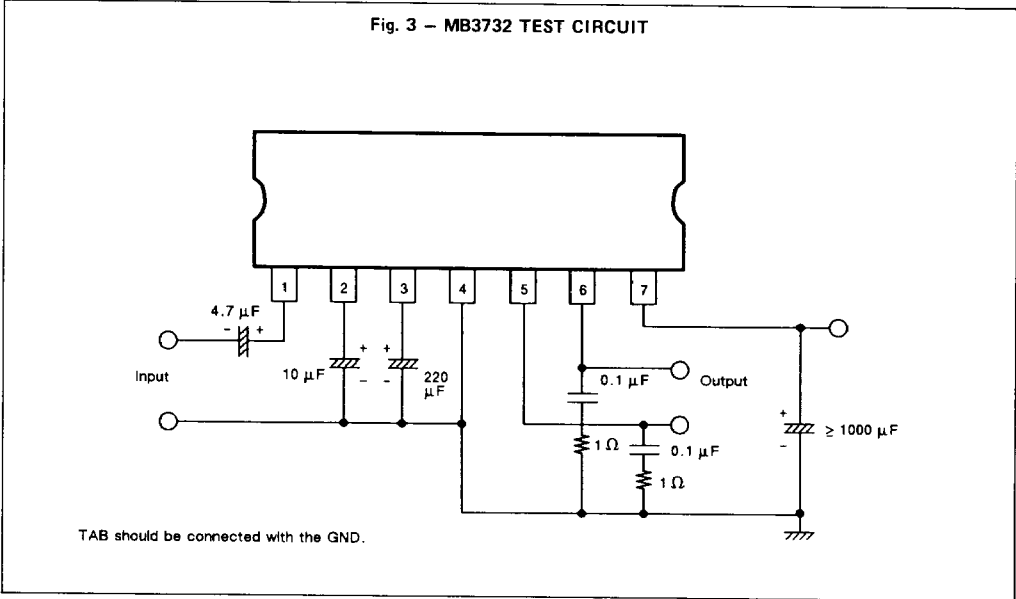
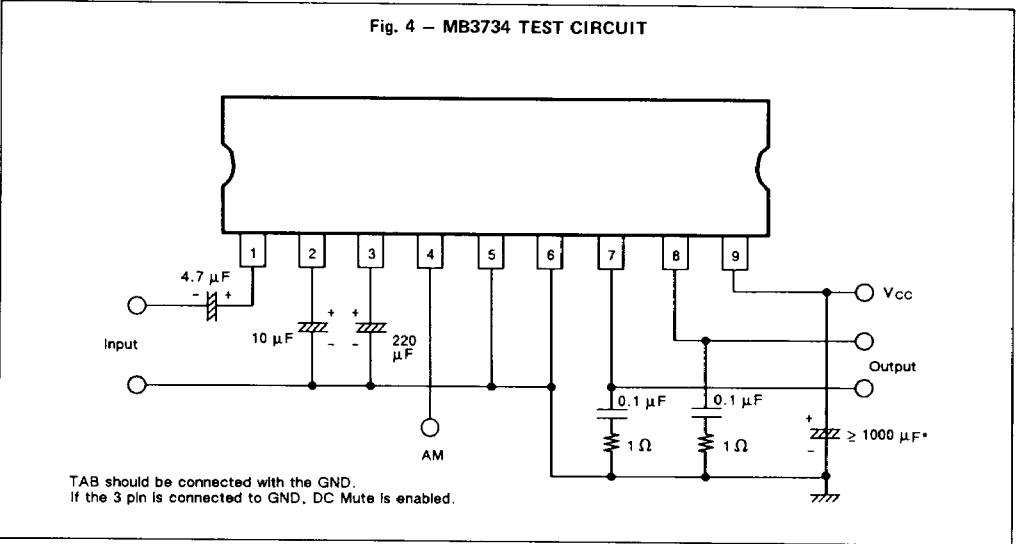

Fig. 4 – MB3734 TEST CIRCUIT



NOTE: *When operation is unstable due to board design, insert 0.1 F condenser between V_{CC} and GND and between both outputs respectively, so that the unstable operation will be restrained.

TYPICAL PERFORMANCE CHARACTERISTICS

Fig. 5 – TOTAL HARMONIC DISTORTION vs. OUTPUT POWER

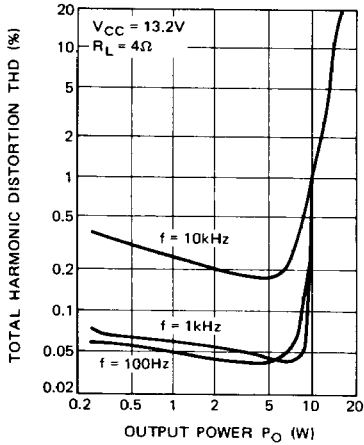
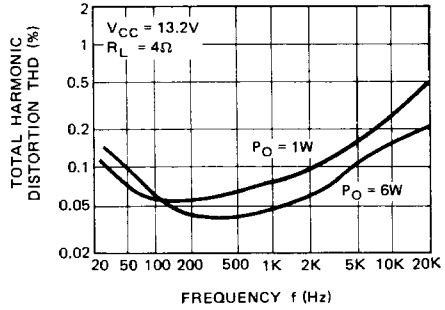

Fig. 6 – TOTAL HARMONIC DISTORTION vs. FREQUENCY



3

Fig. 7 – OUTPUT POWER vs. FREQUENCY

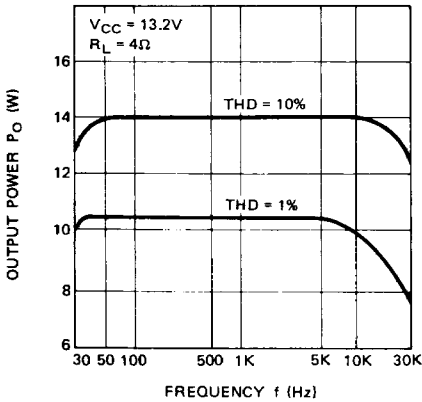
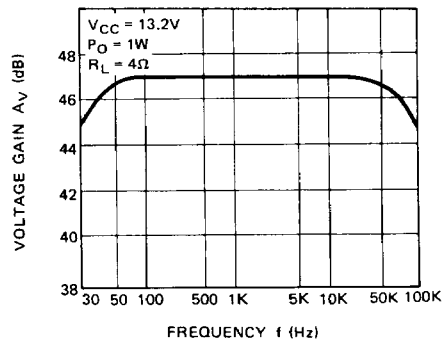

Fig. 8 – VOLTAGE GAIN vs. FREQUENCY





MB3732
MB3734

TYPICAL PERFORMANCE CHARACTERISTICS (continued)

3

Fig. 9 – POWER DERATING CURVE
(MB3732)

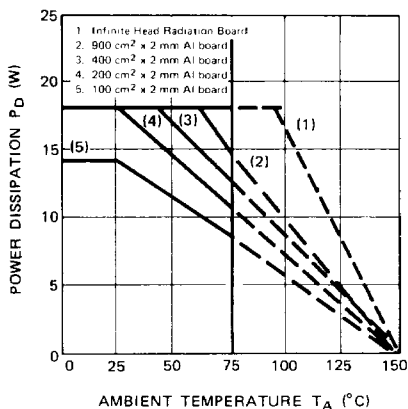
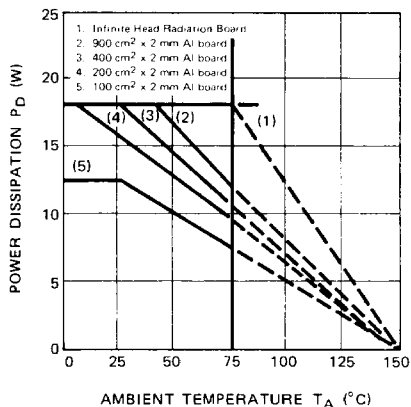
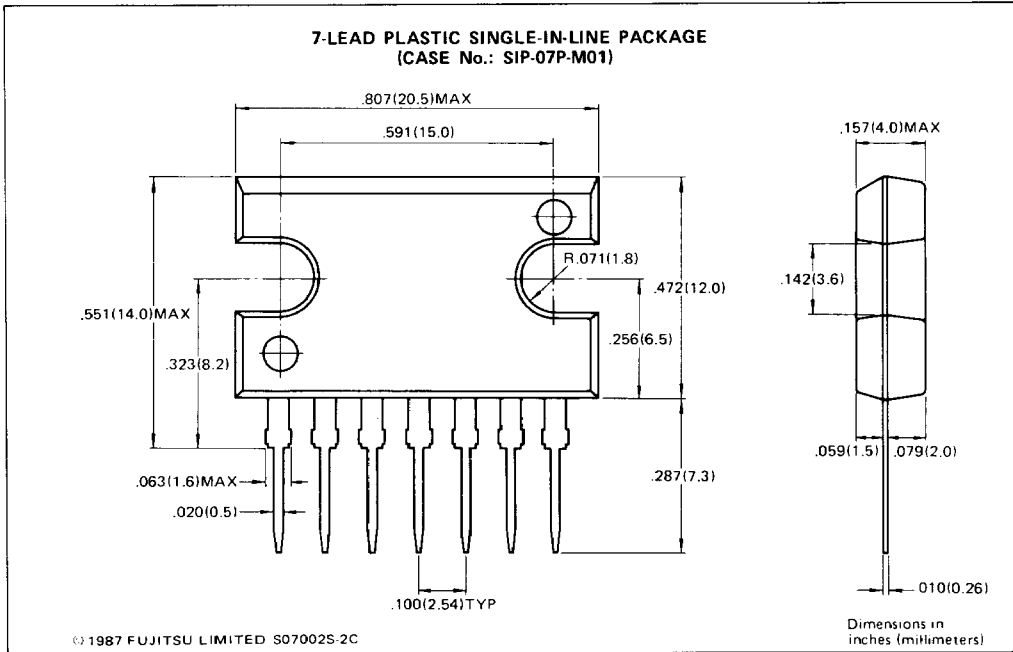

Fig. 10 – POWER DERATING CURVE
(MB3734)



PACKAGE DIMENSIONS



3

PACKAGE DIMENSIONS (continued)

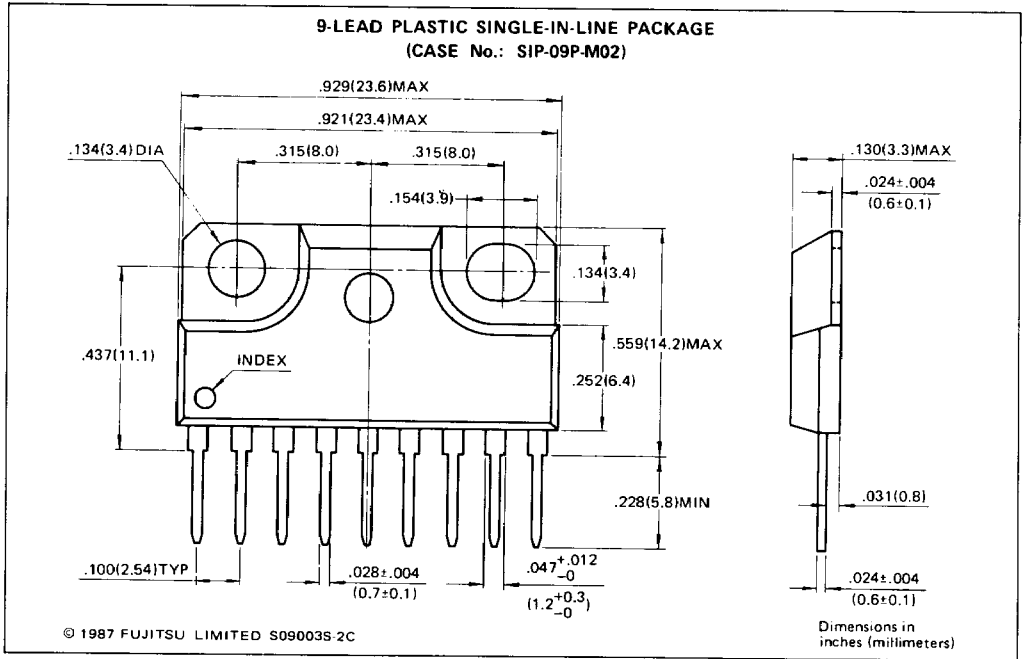

3